

The Economics of Next Generation Access - Final Report

Authors:

Dieter Elixmann

Dragan Ilic

Dr. Karl-Heinz Neumann

Dr. Thomas Plückebaum

WIK-Consult GmbH

Rhöndorfer Str. 68

53604 Bad Honnef

Germany

Bad Honnef, September 10, 2008

Contents

Tables	IV
Figures	VII
Abbreviations	X
Preface	XIII
Executive Summary	XV
1 Introduction	1
2 Literature review	3
2.1 OPTA: Business cases for broadband access	3
2.1.1 OPTA: Business case for sub-loop unbundling in the Netherlands	3
2.1.2 OPTA: Business case for fibre-based access in the Netherlands	5
2.2 Comreg: Business case for sub-loop unbundling in Dublin	8
2.3 BIPT: The business case for sub-loop unbundling in Belgium	10
2.4 Analysys: Fibre in the Last Mile	12
2.5 Avisem studies for ARCEP	15
2.5.1 Sharing of the terminal part of FTTH	16
2.5.2 Intervention of local authorities as facilitators	18
2.6 AT Kearney: FTTH for Greece	19
2.7 ERG opinion on regulatory principles of NGA	23
2.8 JP Morgan: The fibre battle	26
2.9 OECD	28
2.9.1 Public rights of way for fibre deployment to the home	29
2.9.2 Developments in fibre technologies and investment	32
3 Experiences in non-European countries	44
3.1 Australia	44
3.1.1 Overall broadband market penetration	44
3.1.2 Current broadband market structure	45
3.1.3 Envisaged nationwide “Fibre to the Node” network	47
3.1.4 Regulation, wholesale services	50
3.2 Japan	51
3.2.1 Overall broadband market penetration	51

3.2.2	Current broadband market structure	52
3.2.3	Regulation, wholesale services	54
3.3	Singapore: Next Gen NBN	58
3.4	USA	63
3.4.1	Overall broadband market penetration	63
3.4.2	Current broadband market structure	65
3.4.3	Regulation, wholesale services	68
3.4.4	Wrap-up	69
4	Generic business model for NGA	71
4.1	Basic technical network characteristics	73
4.1.1	The FTTC-VDSL model	75
4.1.2	The FTTH PON model	78
4.1.3	The FTTH Point-to-Point model	86
4.1.4	Consideration of regulatory measures	87
4.2	Our overall model approach: characterization	88
4.2.1	Static modelling	90
4.2.2	LRIC greenfield and existing infrastructures	90
4.2.3	Customer demand and market shares	91
4.3	Model input	91
4.3.1	NGA business cases considered	93
4.4	Typical model output	97
5	Empirical evidence in Europe: Country results	100
5.1	Germany	101
5.1.1	Market developments and regulatory background	101
5.1.2	Model results	108
5.2	France	124
5.2.1	Market developments and regulatory background	124
5.2.2	Model results	137
5.3	Italy	147
5.3.1	Market developments and regulatory background	147
5.3.2	Model results	152

5.4	Portugal	162
5.4.1	Market developments and regulatory background	162
5.4.2	Model results	172
5.5	Spain	191
5.5.1	Market developments and regulatory background	191
5.5.2	Model results	195
5.6	Sweden	204
5.6.1	Market developments and regulatory background	204
5.6.2	Model results	209
5.7	General results	217
6	Conclusions and recommendations	225
6.1	Findings and conclusions	225
6.1.1	The economics of NGA	225
6.1.2	Findings from international comparison	226
6.1.3	Policy and regulatory conclusions	227
6.1.4	Conclusions based on our model results	230
6.2	Recommendations	233
6.2.1	Recommendations addressed to European policy-makers	233
6.2.2	Recommendations addressed to EU Commission	234
6.2.3	Recommendations addressed to the ERG	235
6.2.4	Recommendations addressed to NRAs	236
6.2.5	Recommendations addressed to national governments and legislators	238
6.2.6	Recommendations addressed to alternative operators	240
6.2.7	Recommendations addressed to incumbent operators	240
	Bibliography	241
	Annex 1	245
	Details of non-EU country analysis	245
	Singapore	245

Tables

Table 1:	Cost estimates for joint duct deployment together with other civil works according to Avisem	18
Table 2:	Requirements to obtain rights of way according to OECD	30
Table 3:	Price per household and month, depending on the penetration rate	42
Table 4:	Broadband penetration in Australia according to technologies (as of September 2006)	44
Table 5:	Internet service providers with DSLAM infrastructure in Australia	45
Table 6:	Model specification: Clusters of subscriber densities	72
Table 7:	Main assumptions characterising the different cases of our model	96
Table 8:	Spatial distribution of the customer base in Germany	109
Table 9:	Structural parameters of the PSTN network in Germany	109
Table 10:	Assumptions on average revenues per subscriber in Germany	110
Table 11:	Critical market shares under different market and regulatory scenarios for rolling-out VDSL in Germany	113
Table 12:	Critical market shares under different market and regulatory scenarios for rolling-out FTTH-PON in Germany	115
Table 13:	Critical market shares under different market and regulatory scenarios for rolling out FTTH-P2P in Germany	116
Table 14:	ARPU + 10% sensitivities for the VDSL stand-alone case, effects on critical market shares in Germany	119
Table 15:	ARPU + 10% sensitivities for the PON stand-alone case, effects on critical market shares in Germany	121
Table 16:	ARPU + 10% sensitivities for the P2P stand-alone case, effects on critical market shares in Germany	123
Table 17:	Spatial distribution of the customer base in France	138
Table 18:	Structural parameters of the PSTN network in France	138
Table 19:	Assumptions on average revenues per subscriber in France	139
Table 20:	Critical market shares under different market and regulatory scenarios for rolling-out FTTH-PON in France	140
Table 21:	Critical market shares under different market and regulatory scenarios for rolling-out FTTH-P2P in France	142
Table 22:	Spatial distribution of the customer base in Italy	153

Table 23:	Structural parameters of the PSTN network in Italy	153
Table 24:	Assumptions on average revenues per subscriber in Italy	154
Table 25:	Critical market shares under different market and regulatory scenarios for rolling out VDSL in Italy	156
Table 26:	Critical market shares under different market and regulatory scenarios for rolling out FTTH-PON in Italy	158
Table 27:	Critical market shares under different market and regulatory scenarios for rolling out FTTH-P2P in Italy	159
Table 28:	Parameters of quality of service in the Portuguese duct access environment	167
Table 29:	Spatial distribution of the customer base in Portugal	173
Table 30:	Structural parameters of the PSTN network in Portugal	173
Table 31:	Assumptions on average revenues per subscriber in Portugal	174
Table 32:	Critical market shares under different market and regulatory scenarios for rolling out VDSL in Portugal	176
Table 33:	Critical market shares under different market and regulatory scenarios for rolling out FTTH-PON in Portugal	178
Table 34:	Critical market shares under different market and regulatory scenarios for rolling out FTTH-P2P in Portugal	180
Table 35:	Critical market shares for the VDSL incumbent case with infrastructure wholesale revenues in Portugal	184
Table 36:	Critical market shares for the PON incumbent case with additional wholesale revenues in Portugal	186
Table 37:	Critical market shares of the P2P incumbent case with additional wholesale LLU revenues in Portugal	189
Table 38:	Spatial distribution of the customer base in Spain	196
Table 39:	Structural parameters of the PSTN network in Spain	197
Table 40:	Assumptions on average revenues per subscriber in Spain	197
Table 41:	Market and regulatory scenarios for rolling out VDSL in Spain	199
Table 42:	Critical market shares under different market and regulatory scenarios for rolling out FTTH-PON in Spain	200
Table 43:	Critical market shares under different market and regulatory scenarios for rolling out FTTH-P2P in Spain	202
Table 44:	Spatial distribution of the customer base in Sweden	210

Table 45:	Structural parameters of the PSTN network in Sweden	210
Table 46:	Assumptions on average revenues per subscriber in Sweden	211
Table 47:	Critical market shares under different market and regulatory scenarios for rolling-out VDSL in Sweden	212
Table 48:	Critical market shares under different market and regulatory scenarios for rolling-out FTTH-PON in Sweden	214
Table 49:	Critical market shares under different market and regulatory scenarios for rolling out FTTH-P2P in Sweden	215
Table 50:	Investment per home passed (in Euro), urban cluster, stand-alone first mover*	220
Table 51:	Investment per home connected**, market share 50%, urban cluster, stand-alone first mover	222
Table 52:	Shares in investment for active and passive equipment, market share 50%, urban cluster, stand-alone first mover, Germany	223
Table 53:	Capex/ Opex ratio (in %) across technologies and countries (market share 50 %, urban cluster, stand-alone first mover)	224
Table A-1:	NetCo tenderers in Singapore	245
Table A-2:	OpCo tenderers in Singapore	245

Figures

Figure 1:	Average monthly cost per subscriber per genotype for the base fibre case scenario in the Netherlands	7
Figure 2:	Average cost per line - base and optimistic scenario for SLU compared with LLU	9
Figure 3:	Impact of the different network deployment choices and scenarios on the incremental monthly ARPU necessary to cover the additional cost between SLU and LLU	11
Figure 4:	ROI on FTTP deployment	14
Figure 5:	ROI on VDSL deployment	15
Figure 6:	Topologies for PON fibre networks according to OECD	37
Figure 7:	Broadband penetration in Japan according to different technologies	51
Figure 8:	NTT's FTTB/H architecture	52
Figure 9:	Unbundling decision and development of the DSL service market in Japan (March 99 – March 07, in million)	54
Figure 10:	Access charges for FTTH network elements in Japan (as of 2006; E = NTT East; W = NTT West; figures in Yen)	55
Figure 11:	3-level industry structure envisaged in Singapore	62
Figure 12:	Total High-Speed lines in the USA	63
Figure 13:	FTTx player groups in the USA	65
Figure 14:	Architectures of non-RBOCs' deployments in the USA	66
Figure 15:	Verizon strategy to transform the home network	67
Figure 16:	Development of high speed DSL lines 2000 – 2005 and market share of CLECs in the USA	70
Figure 17:	NGN/ NGA network architecture: Illustration	73
Figure 18:	Different technical solutions for deep fibre deployment in the local loop: Illustration	75
Figure 19:	Use of existing (unbundled) sub-loops in an FTTC-VDSL environment: illustration	77
Figure 20:	FTTH PON architecture: Illustration	80
Figure 21:	Fibre sub-loop unbundling in the case of PON: Illustration	81
Figure 22:	Simple WDM PON : Illustration	83
Figure 23:	Simple WDM PON with λ -filtering ONUs: Illustration	84

Figure 24:	TDMA PON with xWDM PON, regional groups: Illustration	84
Figure 25:	TDMA PON with xWDM PON, operator oriented groups: Illustration	85
Figure 26:	FTTH Point-to-Point: Illustration	86
Figure 27:	Determination of the critical market share for a single cluster: illustration	97
Figure 28:	Critical market shares across different clusters: illustration	98
Figure 29:	Model results for the VDSL roll-out of the incumbent in Germany	111
Figure 30:	VDSL cost curve of the incumbent in the dense rural cluster in Germany	112
Figure 31:	NGA roll-out opportunities of the incumbent by technology in Germany	117
Figure 32:	NGA roll-out opportunities of an alternative operator in case of 80% infrastructure sharing in Germany	118
Figure 33:	ARPU + 10% sensitivities for the VDSL stand-alone case, effects on critical market shares in Germany	120
Figure 34:	ARPU + 10% sensitivities for the PON stand-alone case, effects on critical market shares in Germany	122
Figure 35:	ARPU + 10% sensitivities for the P2P stand-alone case, effects on critical market shares in Germany	124
Figure 36:	Costs per subscriber and planned total subscribership according to FT's roll-out plan for FTTB/H (2006 – 2012)	127
Figure 37:	Features of the strategic fibre deployment plan of Free/Iliad	129
Figure 38:	NGA roll-out opportunities of the incumbent by technology in France	143
Figure 39:	NGA roll-out opportunities of an alternative operator in case of 80% infrastructure sharing in France	144
Figure 40:	WACC of 10.25 vs. 15% in the case incumbent PON in France	145
Figure 41:	WACC of 10.25 vs. 15% in the case of P2P in France	145
Figure 42:	WACC of 15% applied on SLU fee in the case of PON SLU 80% infrastructure sharing in France	146
Figure 43:	NGA roll-out opportunities of the incumbent by technology in Italy	160
Figure 44:	NGA roll-out opportunities of an alternative operator in case of 80% infrastructure sharing in Italy	161
Figure 45:	Information requests and volume of orders in the Portuguese duct access system, January 2007 – March 2008	169
Figure 46:	NGA roll-out opportunities of the incumbent by technology in Portugal	181
Figure 47:	NGA roll-out opportunities of an alternative operator in case of 80% infrastructure sharing in Portugal	182

Figure 48:	Critical market shares for the VDSL incumbent case with infrastructure wholesale income in Portugal	185
Figure 49:	Critical market shares in the PON incumbent case with infrastructure wholesale income in Portugal	187
Figure 50:	Critical market shares for the P2P incumbent case with additional wholesale fibre LLU revenues in Portugal	190
Figure 51:	NGA roll-out opportunities of the incumbent by technology in Spain	203
Figure 52:	NGA roll-out opportunities of an alternative operator in case of 80% infrastructure sharing in Spain	203
Figure 53:	NGA roll-out opportunities of the incumbent by technology in Sweden	216
Figure 54:	NGA roll-out opportunities of an alternative operator in case of 80% infrastructure sharing in Sweden	216

Abbreviations

ADSL	Asynchronous Digital Subscriber Line
AON	Active Optical Network
ARCEP	Autorité de Régulation des Communications électroniques et des Postes
ARPU	Average Revenue per User
ATM	Asynchronous Transfer Mode
BIPT	Belgisch Instituut voor postdiensten en telecommunicatie
B-RAS	Broadband Remote Access Server
CATV	Cable TV
CPE	Customer Premise Equipment
CLEC	Competitive Local Exchange Carrier
Cu	Copper
CWDM	Coarse Wavelength Division Multiplexing
DOCSIS	Data over Cable Service Interface Specification
DSL	Digital Subscriber Line
DSLAM	DSL Access Multiplexer
DWDM	Dense Wavelength Division Multiplexing
ECNS	Electronic Communication Network services
ECTA	European Competitive Telecommunications Association
EPON	Ethernet Passive Optical Network
ERG	European Regulators Group
FD	Framework Directive (EC Directive 2002/21/EC)
FTTB	Fibre to the Building
FTTC	Fibre to the Curb
FTTH	Fibre to the Home
FTTN	Fibre to the Node
FTTP	Fibre to the Premise
FU	Fibre Unbundling
GigE	Gigabit Ethernet
GPON	Gigabit Passive Optical Network
HFC	Hybrid Fibre Coax
HSDPA	High Speed Download Packet Access
IP	Internet Protocol
IRU	Indefeasable Right of Use
ISP	Internet Service Provider

ITU-T	International Telecommunications Union – Telecommunication Standardisation Bureau
LER	Label Edge Router
LLU	Local Loop Unbundling
LRIC	Long Run Incremental Cost
LSR	Label Switch Router
MCL	Metro Core Location
MDF	Main Distribution Frame
MoU	Memorandum of Understanding
MDU	Multi Dwelling Unit
NGA	Next Generation Access
NGAN	NGA Network
NGN	Next Generation Network
NPV	Net Present Value
NRA	National Regulatory Authority
NRO	Remote Optical Node
ODF	Optical Distribution Frame
OLT	Optical Line Terminator
ONT	Optical Network Terminator
ONU	Optical Network Unit
OSDF	Optical Street Distribution Frame
P2P	Point to Point
PON	Passive Optical Network
PSTN	Public Switched Telephone Network
QoS	Quality of Service
RGU	Revenue Generating Unit
RO	Reference Offer
ROI	Return on Investment
SC	Street Cabinet
SDF	Street Distribution Frame
SLA	Service Level Agreement
SLU	Sub-loop Unbundling
TDM	Time Division Multiplex
TDMA	Time Division Multiple Access
TV	Television

ULL	Unbundled Local Loop
UPS	Uninterruptible Power Supply
VDSL	Very High Speed DSL
VoB	Voice over Broadband
VoIP	Voice over IP
VPN	Virtual Private Network
WACC	Weighted Average Cost of Capital
WBA	Wholesale Bitstream Access
WDM	Wavelength Division Multiplex
WiBro	Wireless Broadband (Korean standard)
Wi-Fi	Brand name for certified Wireless LAN
WiMax	Worldwide Interoperability for Microwave Access
xDSL	x Digital Subscriber Line

Preface

On April 29, 2008, the European Competitive Telecommunications Association (ECTA) commissioned the study on “The Economics of Next Generation Access” from WIK-Consult.

Work for this study has been carried out between May and August 2008.

In the course of the study we have presented our approach for this study and preliminary results to a workshop attended by ECTA members. Preliminary results of the study have also been presented at ECTA’s “High Speed Europe” event on 25 June in Brussels.

The present document is the Final Report of our study.

Many people from several organisations from all over Europe have contributed in one way or another to this study. Particularly useful (in fact indispensable) were actual data from market players in Germany, France, Italy, Portugal, Spain, and Sweden, which has been incorporated into the model. Moreover, the questions and comments that we received at the ECTA workshop and the ECTA “High Speed Europe” event were very useful. The authors of this study would like to thank all of the contributors from industry, from the European Commission, from NRAs, from consultancies, and from ECTA Members very much; space does not allow to name them all personally. Finally, we would like to thank ECTA very much that the study was awarded to us. Needless to say, that nobody other than the authors is responsible for any omissions, misconceptions, errors, etc. in this study.

Bad Honnef, September 2008

Executive Summary

1. The European Competitive Telecommunications Association (ECTA) commissioned this study on "The Economics of Next Generation Access" from WIK-Consult on April 29. The main objective of the study is the assessment of the viability of next generation access business models and the analysis how regulation might support viable duplication of infrastructure whilst ensuring competition in the provision of services to consumers and businesses. The study also gives an overview of recent studies dealing with NGA in Europe and abroad (Australia, Singapore, Japan and the USA).
2. To meet the objectives of the study, we have developed a generic business model. This model on the one hand enables the assessment of the viability of next generation access business models and the potential national coverage of NGA. On the other hand it provides the opportunity to derive conditions (in particular regulated wholesale services) that allow a maximum degree of viable duplication (replicability) of a first mover's investment. However, as the term "generic" suggests, the model structure and logic itself is independent from the conditions in a specific country or area. Rather, the model requires to feed in real world data about a country or an area within a country in order to generate actual empirical results (which are then country/area specific). The model for the first time gives particular emphasis on the impact of certain regulatory decisions on access regarding NGA.
3. There are already several studies that focus on various facets of fibre deployment in the access network. Likewise, there are already several models available which are focusing on certain aspects of the viability of deep fibre deployment. The present study covers all relevant aspects in a comprehensive way. We review the relevant literature and models, we analyse actual fibre deployment approaches in several countries in and outside Europe, we present the main features of our model and we apply this model to generate empirical results for altogether six European countries (Germany, France, Italy, Portugal, Spain, Sweden). For all six countries we provide comprehensive empirical evidence on the viability of replication of VDSL/FTTC infrastructure as well as of the deployment of FTTB/H infrastructure. We also show quantitatively and not only qualitatively the impact of regulatory measures like duct and dark fibre access, fibre loop and sub-loop unbundling on the replicability of NGA roll-out and competition. On the basis of our model results we derive recommendations on the necessary regulatory conditions for effective competition in NGA.
4. We have structured the model to calculate fibre deployment for eight coverage areas or "clusters" in each country defined by population density with the expectation that profitability of NGA deployment depends on population density.

5. We assume an advanced state of network development in which 80% of all subscribers to fixed telecoms receive double or triple play services whilst the remainder receive telephony alone. This is higher than the take-up of these services today, but is considered a reasonable expectation over the horizon of an investment decision.
6. Market shares listed indicate shares of all households and businesses (potential subscribers), which may include households without fixed connections or with cable services. The results should be read in this context. For example a typical leading entrant serves 10-20% of broadband subscribers in the market today. In a country where 50% households subscribe to broadband, this broadband market share would equate to a market share of between 5-10% of all households (potential customers).

Model results

7. We have modelled three architectural approaches for NGA: FTTC/VDSL, FTTH PON and FTTH P2P. In general, the investment requirements (and the resulting impact on coverage and critical market shares to be achieved for profitability) are ranked in the order above. The lowest investment is required by VDSL, followed by PON and then by P2P. This ranking does not consider the different capabilities of the architectures to support high bandwidth, to be future-proof or to facilitate any unbundling requirements.
8. NGA deployment requires significant investments. The following table shows the investment per home connected across the various NGA architectures derived from our model.

Investment per home connected (in Euro), market share 50%, urban cluster, stand alone first mover **

Network Type	Country [in €]					
	DE	FR	SE	PT	ES	IT
VDSL	457	n.v.	352	218	254	433
PON	2,039	1,580	1,238	1,411	1,771	1,110
P2P	2,111 (54%)	2,025	1,333	1,548	1,882	1,160

** Based on the investment of the urban cluster and a market share of 50%. If other market shares are used, it is mentioned in brackets.

n.v. – not viable

The investment requirements are reported for the urban roll-out cluster and a market share of 50% of the potential customer base. They include CPE and inhouse cabling in case of FTTH. The figures in the table show the investment requirements for an operator without existing infrastructure such as ducts and are based on current costs. As such they are most relevant when assessing the costs

for alternative (non-incumbent) operators in the absence of regulation. The following results are worth highlighting.

8.1 NGA investment requirements are very much dependent on national specificities (e.g. low civil engineering costs in Portugal, renting ducts in the distribution cable segment in Italy instead of own investment).

8.2 FTTC/VDSL requires much less investment than FTTH due to saving the distribution cable segment by using the existing copper sub-loops and saving the inhouse cabling.

8.3 FTTH requires roughly 5-times higher investments than VDSL. The more future-proof and open network friendly P2P FTTH architecture requires less than 10% additional investment than the PON architecture.

9. A nationwide NGA roll-out is not profitable in any of the six countries analysed on the basis of current costs. This result holds for any NGA technology and even for a monopolistic market structure (except VDSL in Italy, due to country specific circumstances). The area of NGA coverage beyond the level of profitable roll-out can only be expanded with public funding or subsidies.

10. The following table provides an overview of the proportion of households that could be profitably covered by incumbents for all six countries considered in this study on the basis of current costs (neglecting already depreciated assets). The results are shown for all three architectures.

Viability of NGA roll-out for incumbents across countries and technologies

Network Type	Country					
	DE	FR	SE	PT	ES	IT
VDSL	71.5%	n.r.	18.3%	39.0%	67.4%	100.0%
PON	25.1%	25.2%	18.3%	19.2%	12.2%	17.6%
P2P	13.7%	18.6%	18.3%	19.2%	12.2%	12.6%

n.r. – not realisable

The incumbent in Germany can profitably roll out VDSL for 71.5 % of the population while economic viability in less densely populated Sweden ends at 18.3 % of population. The profitable range for an FTTH roll-out is significantly lower and is in the range from 12 to 25 % across the six countries.

11. Our base case assumes, consistent with fibre-rich countries such as Japan and with developments in European markets such as France, that consumers will not pay substantially more for higher bandwidths provided over NGA but we reflect in the ARPU assumptions that telecoms operators will capture a higher proportion of the TV market than is typical today. Sensitivity tests show that an increase of 10%

in ARPUs for VDSL in Germany would reduce the critical market share required for a stand-alone first mover in most geographic areas by around 25% compared with the base case whilst FTTH viability is less sensitive to ARPU increases – reducing the critical share by 13% for PON and 16% for P2P (see diagram below). A reduction in expected ARPUs would reduce the area of profitable roll-out.

ARPU sensitivities for the P2P stand-alone case, effects on critical market shares in Germany

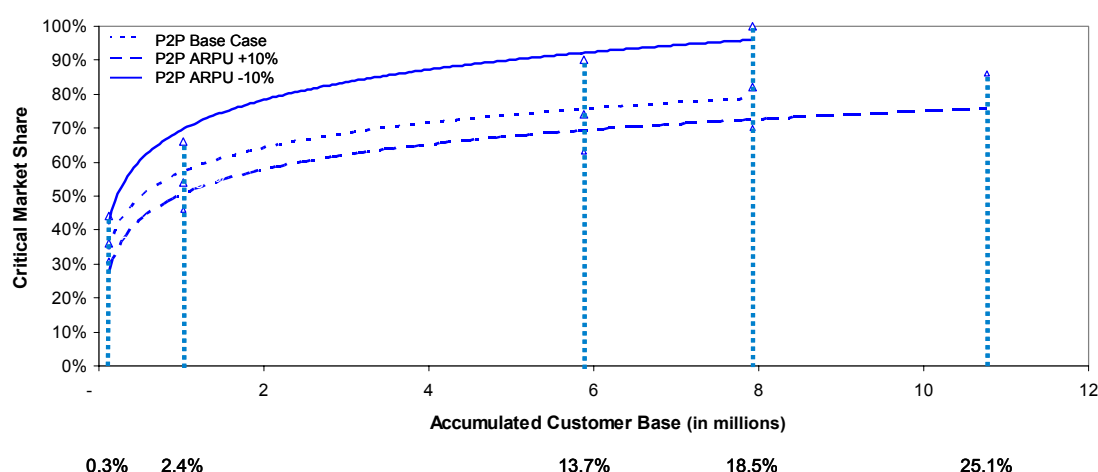

12. Our model exhibits the importance of scale and scope economies limiting the degree of replicability. Where viable, replication of the incumbent's NGA requires a more significant scale and/or market share for alternative operators compared with current business models based on local loop unbundling. This limits the number of feasible competitors in the access network.
13. The next table shows the profitable range of a second mover's NGA roll-out. These results are provided for the optimistic scenario that the second mover has access to 80 % of existing ducts at current cost-based prices or equivalent facilities such as sewers. Where duct or sewer access is available or under negotiation actual or proposed prices have been used for the model.

Replicability of NGA roll-out for a second mover, 80 % access to existing ducts at current cost-based prices

Network Type	Country					
	DE	FR	SE	PT	ES	IT
VDSL	18.5%	n.r.	n.v.	39.0%	n.r.	17.6%
PON	0.3%	6.8%	n.v.	n.v.	n.v.	1.6%
P2P	0.0%	6.8%	n.v.	n.v.	n.v.	0.2%

n.v. – not viable
n.r. – not replicable

- VDSL in Portugal is replicable for 39 % of population and for 18.5 % in Germany. Across all countries there is only relatively low replicability of FTTH infrastructure. The most viable country for FTTH duplication is France where, mainly due to accessibility of sewers in Paris, at least 6.8 % of the population can be profitably covered by a second mover.
14. Replicating the incumbents' VDSL network roll-out by alternative operators is less viable than the current LLU approach of alternative operators. In a VDSL NGA environment, the current degree of LLU based competition does not seem to be replicable. These results are similar to those generated in studies carried out for NRAs in the Netherlands, Ireland and Belgium.
 15. As indicated by other studies and/or analytical expectations, our model results support the finding that civil engineering cost and inhouse wiring are key barriers to replicability in FTTB/H NGA deployment. However, addressing these barriers by regulatory measures will not alone be sufficient to deliver competitive outcomes.
 16. Incumbents are better placed than alternative operators to invest in NGA on a large scale:
 - 16.1 Incumbents can rely on the availability of major network elements needed for NGA (locations of street cabinets, ducts, fibre) which they might use at their book values. Alternative operators still have to invest.
 - 16.2 Incumbents can save (economically) investments by generating lump-sum revenues due to dismantling of MDFs and selling the respective locations. These savings are modelled in the incumbent scenarios included in the report.
 - 16.3 Incumbents can make better use of economies of scale and scope due to their larger subscriber base (80-90% of local loop, around 50% of retail broadband customers) compared to that of the leading broadband competitor (10-15% retail market share), which they can migrate to NGA.
 - 16.4 Alternative operators usually face a higher cost of capital than incumbents due to their size and risk position.
 - 16.5 Due to the factors mentioned above, investments in NGA are more risky for alternative operators than for incumbents. Yet, alternative operators may act as first movers in NGA because their current business model as a whole is under threat.
 - 16.6 For areas shown as viable, and where incumbents currently have the required market share of access lines to make a fair return and have

depreciated existing copper loops, little or no risk may be incurred, and the FTTx investment constitutes normal infrastructure renewal.

17. Our model results show that incumbents can reduce their own costs by infrastructure sharing, can increase the profitability of their NGA roll-out and can reach profitability with a lower level of retail market shares if they provide wholesale services (i.e. wholesale revenues can substitute for retail revenues to a significant degree). This result suggests that investment cases of incumbents may be supported rather than undermined through open access regimes, whilst delivering market outcomes that are more compatible with effective competition. Our model suggests in the sample case of Portugal that if only duct access were available, the presence of second market players deploying fibre access would significantly improve the incumbent's profitability but the market structure would tend to support only two significant fibre operators. A model in which wholesale fibre LLU or SLU was available would lower the critical retail market share for the incumbents' profitability whilst supporting a number of additional players (see diagram below).

Critical market shares for the P2P incumbent case with additional wholesale fibre LLU revenues in Portugal

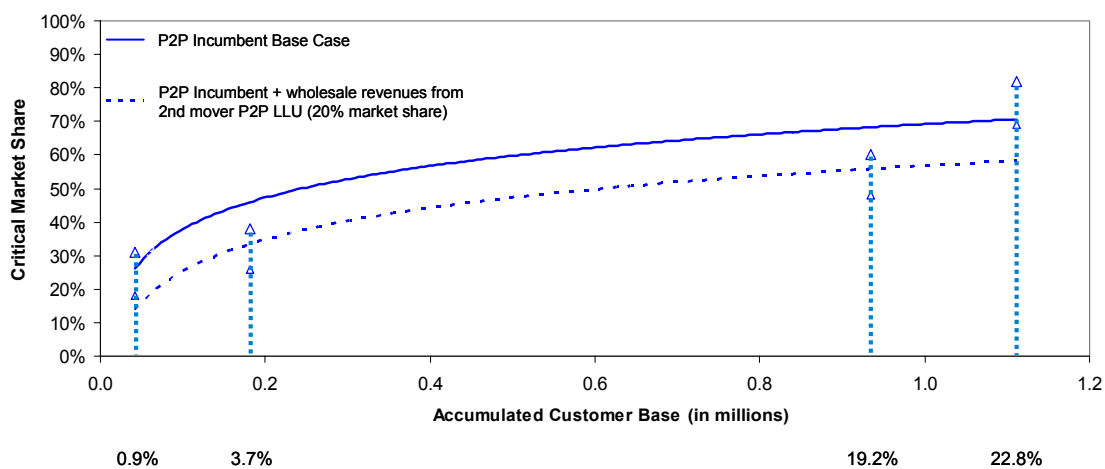

18. Our model results underline the importance of efficiency in the duplication of infrastructure. If more access networks are rolled out than suggested viable by the model or if particular access network providers fail to achieve the critical market shares calculated, market players would either need to charge higher retail prices to recoup their investment or have to face major stranded investment failing to make a fair return on investment. A similar situation due to overinvestment in backbone and undersea cables occurred when the internet bubble burst in 2000/01.

19. The economics of FTTx do not support multiple replication of the access network sufficient to achieve effective competition. In case of (theoretical) replicability usually only one or in rare cases two operators (in addition to the first mover) can profitably invest in NGA infrastructure. In any case, replicability is limited to denser populated areas.
20. Introducing access remedies and/or wholesale products in addition to duct access lowers the critical market shares required for profitability and increases the degree and potential for competition. Access opportunities enable competition wherever a first mover (e.g. the incumbent) rolls out a FTTH NGA infrastructure and require lower market shares for profitability commensurate with market shares that might be realistically achievable in a competitive environment. Fibre LLU and SLU are also the prerequisite for getting (at least) the same degree of competition as under the current unbundling model in the PSTN.
21. The following diagram shows for those countries where this scenario is most relevant the critical shares of potential subscribers (all households and businesses) for an entrant in the urban cluster for different regulatory scenarios.

Impact of regulatory measures on the critical market shares of alternative operators in the urban cluster

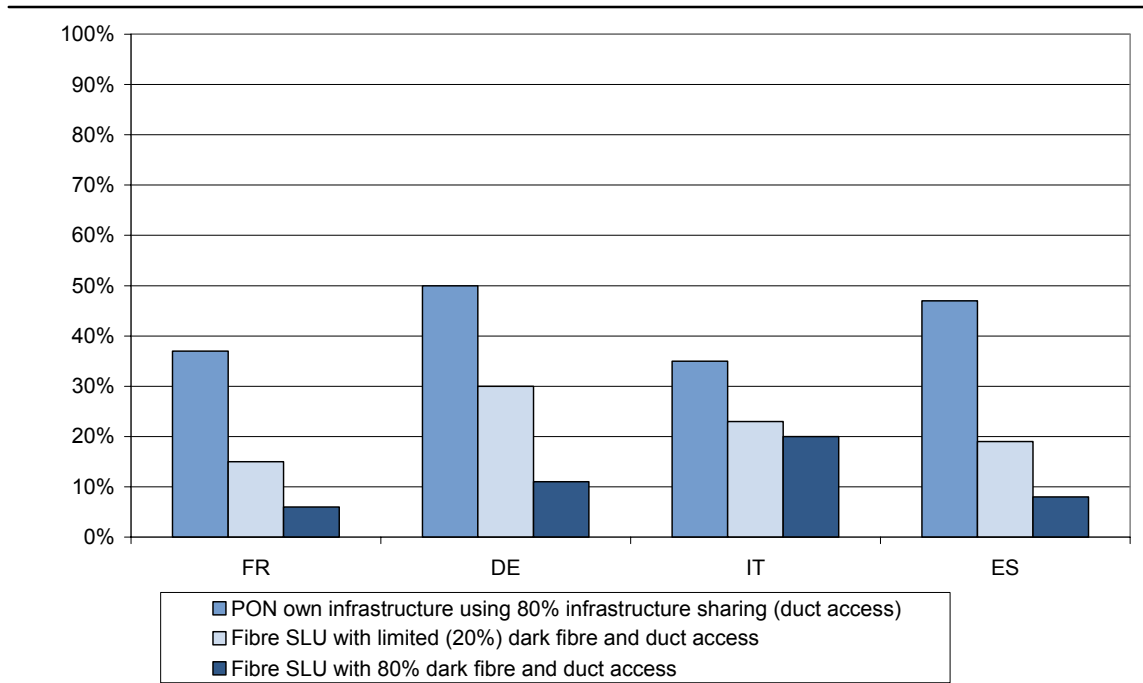

22. We have modelled several regulatory measures relating to the use and sharing of infrastructure. These measures can be combined with each other in a relevant form. Some combinations of regulatory measures result in more efficient network

roll-outs than pure solutions of one type, depending on the architecture. Thus, choice between different regulatory options (wholesale products) increases the efficiency of NGA investments.

23. In a VDSL/FTTC environment, our model results show quantitatively the importance of efficient backhaul solutions between the street cabinet and the operator's network node. The necessity of establishing stand-alone backhaul services limits the replicability of FTTC NGA development significantly. Thus, the availability of proper access products and the choice between duct access and dark fibre backhaul, improves replicability.
24. In an FTTH NGA environment, the current degree of competition based on LLU can only be maintained if fibre SLU (in case of PON architecture) and/or fibre LLU (in case of P2P architecture) are available as access products together with appropriate backhaul. Fibre LLU and fibre SLU increase replicability significantly and enable viable competition in all clusters where a first mover rolls out the FTTH infrastructure. Replicability is not given in less populated clusters.
25. Our model results show that the market shares required for SLU solutions are compatible with competitors having significant scale in the mass market and focusing on covering in more densely populated regions. However, these market shares are unlikely to be achievable for business service providers whose coverage is more dispersed and whose local market shares are typically lower.
26. The effectiveness of regulated access on increasing replicability and competition is strongly affected by the price of access including the WACC. Sensitivities on the level of the cost of capital show the critical dependency of NGA profitability and coverage from this parameter. Increasing the WACC for instance in France from 10.25% to 15% reduces the viable coverage of a PON FTTH infrastructure from 18.6% to 6.8% of population. In the viable areas the critical market shares for profitability increase significantly. If only the WACC for the regulated wholesale services on the SMP operator is increased by the same degree, the critical market shares (or the costs) of competitors increase significantly and the viable addressable customer base decreases (see diagram below). These results show how careful regulators have to deal with a risk premium approach to incentivise investments in NGA. If wholesale rates are fixed significantly above the relevant NGA project risk, replicability and competition can be heavily affected.

Increase of WACC from 10 to 15% applied on SLU fees in the case of PON SLU in France

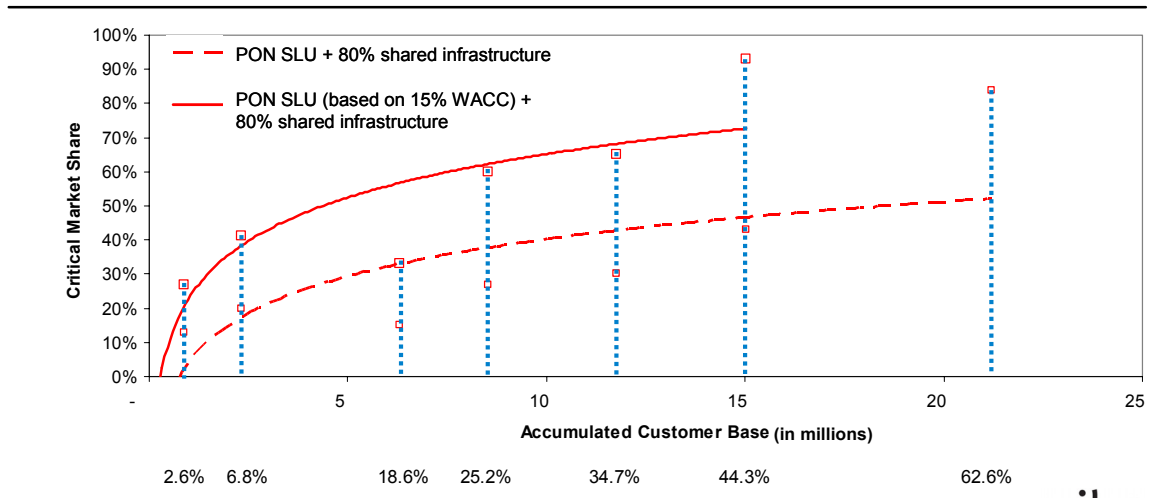

Regulatory and policy recommendations

27. The economics of rolling out fibre access networks require high market shares which in most cases are not compatible with effective competition. This is a structural issue relating to the high costs of laying physical infrastructure in a typical European environment (medium density, buried cables). Policy-makers should set realistic objectives for regulators on this basis which recognise that there are structural barriers to infrastructure-based competition in the access network and more widely in rural areas which must be addressed by regulators to achieve effectively competitive outcomes.
28. Open access models should be positive for investors and favoured by policy makers exploiting the potential of innovation and competition.
29. Policy-makers and regulators must act quickly to identify their preferred model for NGA deployment and expectations regarding openness of networks. Whilst policy makers cannot mandate particular network structures, signaling expectations of reasonable access conditions in case of SMP and indicating that access pricing will be calculated on the basis of efficient architectures can help to ensure that access owners take account of requirements for openness in the network architectures they adopt.
30. Policy-makers should take care that local loop unbundling and sub-loop unbundling are defined in a technologically neutral manner that includes fibre lines and not just metallic lines. It is likely that regulated access to fibre networks will be needed, in addition to duct access, to deliver effective competition in most cases.

31. Policy makers should aim for efficient investment so that infrastructure is rolled out profitably, with minimum risk for the economy and with a maximum reach. Policy-makers should avoid making assumptions on the degree of investment which is efficient, but enable operators to invest efficiently based on a set of options (the ladder of investment).
32. Policy makers should promote service competition and infrastructure-based competition at the same time. Provided the wholesale price is correctly established and allows a fair return, regulated access to fibre does not preclude and can provide a platform for further infrastructure duplication where this is efficient. Our model shows that reasonably priced access is also compatible with and enables fibre investment with lower retail market shares and less risk than would otherwise apply.
33. Rewarding risk appropriately is important in ensuring that investment occurs. A solution could be to increase the allowed WACC for risky projects. However, policy-makers should not recommend particular (additional) risk premiums for all NGA investments. Investing in next generation access networks may be risky in some circumstances and may constitute relatively risk-free renewal of equipment in others. The assessment of the level of riskiness and calculation of the appropriate price should be carried out on a case by case basis by the regulator. A WACC that is too low will limit investment, whilst an excessive WACC would undermine the degree of competition which is sensitive to the price of access.
34. Certain models of risk rewarding or sharing are not compatible with competition or may at least harm competition. Legislators should not stipulate pricing structures, but adopt the principle that regulated prices must allow a fair return appropriately reflecting risk, and that pricing structures adopted should achieve this whilst also being compatible with promoting competition.
35. Transparency about planned deployment of NGA networks is a prerequisite both for developing a proper regulatory framework for effective transition and for providing economic efficient incentives for NGA deployment. This presumption holds in particular for the investment decisions of alternative operators; it is, however, of important relevance for incumbents' investment decisions as well. Despite the fact that NRAs have the legal power based on Art. 5 FD to request the relevant information from operators, there is significant lack of transparency of the incumbents' NGA strategy and the future of the existing unbundling wholesale services in many Member States. Lack of transparency can increase the level of sunk cost in the transition to NGA, can generate economically unjustified first mover advantages and reduce the potential for competition in NGA.

36. A range of access products are needed for a competitive NGA market:
 - 36.1 Duct and dark fibre access increase the level of infrastructure replicability, but are not alone sufficient for viable competition.
 - 36.2 Physical collocation at the street cabinet level increases the limited degree of replicability in case of FTTC.
 - 36.3 Fibre full local loop unbundling (at metro core locations) and fibre sub-loop unbundling (at OSDF) increase the scope for competition significantly, and are particularly relevant for established mass-market broadband providers.
 - 36.4 Bitstream access remains important to maintain existing levels of competition where full LLU is not technically feasible, to support the ladder of investment concept, for less urban areas where unbundling is not economically viable and for business service providers whose market shares are unlikely to reach critical levels.
 - 36.5 In addition, the regulatory framework has to deal with the sunk investments of competitors related to LLU infrastructure to enable a viable migration path to NGA.
37. NRAs should develop unbundling approaches for fibre loops in the context of market analysis and remedies relating to the new Market 4. The current unbundling approach defined for the copper PSTN network should be expanded in a technologically neutral manner to fibre. In case of a P2P architecture fibre local loop unbundling should be provided at the metro core locations. In case of a PON architecture fibre sub-loop unbundling should be provided at the OSDF. The location of the OSDF should allow the efficient replication of network infrastructure.
38. NRAs have to take care that incumbents do not receive first-mover advantages in NGA deployment such that possible replicability will de facto be jeopardised. This means in particular that relevant access products are not only available in principle but are effectively available in due time.
39. Regulators should do more than they did with regard to LLU to shorten the gap between imposing NGA related remedies and the actual availability of the relevant wholesale services. In the case of LLU the implementation delay in some countries amounted to several years. Given the relevance of first-mover advantages, similar gaps in NGA can endanger the (limited) potential of replicability even more or totally.
40. When mandating wholesale broadband access NRAs should ensure that the SMP operator makes available, on a non-discriminatory basis, all technical capabilities embedded in its NGA, to enable alternative operators to define their own products with own QoS. Multicast capability is one such technical capability.

41. NGA development per se does not require to address the issue of sub-national markets. NGA will only have an impact on the need to define sub-national markets for certain markets and/or to differentiate remedies on a geographic basis if the degree of replicability of access services increases due to NGA investments.
42. To minimise the level of sunk costs in the transition to and to set proper incentives for efficient investments in NGA, NRAs should use their statutory powers immediately to make the transition to NGA in their respective country transparent if they haven't done so yet.

1 Introduction

Throughout the world many investment projects are planned (launched, sometimes already completed) that in one way or another change the existing copper-based physical infrastructure in the local loop by deploying fibre (henceforth also called “deep fibre”), and, thus, bringing more bandwidth to end users in the business and the residential market. Players in this respect are both incumbents and competitors deploying “Next Generation Access” (NGA) networks. Yet, the fibre deployment ventures in more or less all countries are not ubiquitous from a geographical perspective, rather, they usually are geographically focused, i.e. fibre is deployed first and foremost in densely populated areas.

Against the backdrop of the current regulated copper-based market situation deployment of fibre in the local loop brings about new issues with regard to competition in the telecommunications sector. This is the case e.g. due to technological characteristics of fibre infrastructures and economic characteristics of fibre based business models.

The present study is motivated by two important questions:

- What are the (technological, economic, market etc.) conditions that make a fibre deployment in the access network viable (in a sense to be made precise) in a given area, provided the investor is the “first mover”?
- What are the conditions that enable a second, third, ... mover to follow suit, i.e. to secure the viability of his business case for the deployment of fibre infrastructure in the access network (when the first mover is already there)?

To this end, we have developed a generic business model. This model on the one hand enables the assessment of the viability of next generation access business models. On the other hand it assesses the extent to which a second or third mover could replicate the first mover’s investment and provides the opportunity to derive conditions (in particular regulated wholesale services) that allow further entry to achieve viable competition. It can be taken for granted that the viability of a business model for deep fibre deployment in a specific area (within a given country) rests heavily on particular conditions within this area. Factors include e.g. demographic patterns (e.g. number of people or households, population density), existing communications network infrastructures (e.g. number of main distribution frames, number of street cabinets), prices for digging up streets, and existing “other” network infrastructures (e.g. sewage channels that can be used to deploy fibre infrastructure to avoid digging). However, as the term “generic” suggests, the model structure and logic itself is independent from the conditions in a specific country or area. Rather, the model requires to feed in real world data about a country or area in order to generate actual empirical results (which are then country/area specific).

There are already several studies that focus on various facets of fibre deployment in the access network. Likewise, there are already several models available which are focusing in one way or another on the viability of deep fibre deployment.

In the present study we cover all of these aspects, i.e. we review the relevant literature and models (to the extent that descriptions of the models are available), we analyse actual fibre deployment approaches in several countries in and outside Europe, we present the main features of our model and we apply this model to generate empirical results for altogether six European countries (Germany, France, Italy, Portugal, Spain, Sweden).

From a methodological perspective our study rests on several pillars: First, there is desk research of published studies and existing models. Second, we have carried out specific country studies. Third, we have conducted interviews with experts from ECTA members, NRAs and other stakeholders who in particular have provided data on the six European countries for which this study presents actual empirical evidence. Fourth, we rely on our own long standing expertise with cost model development.

Regarding the empirical evidence provided in this report for the six European countries we have to underline an important fact of life: model results can only be as good as the data on which the model is based. Substantial parts of the data used in this study has been provided by market participants from the different countries. It is, however, worth stressing that there are still information asymmetries in all of these national markets across the market participants with respect to data for critical parameters and variables of the model. To be more precise, very often regulators and competitors do not have full information about network characteristics of the incumbent which are relevant for the model (e.g. number of street cabinets, sub-loop lengths etc.). We have provided the model infrastructure which enables market participants and regulators to derive model results with different parameter sets, which they perhaps regard more realistic.

Overall in this study, data about actual developments in markets has been taken into account of up to the end of May/beginning of June 2008.

The report is organized as follows. Chapter 2 focuses on a literature review. Chapter 3 is devoted to studies of four non-European countries. In this chapter we address their specific approaches and experiences with deployment of fibre in the local loop. In Chapter 4 the actual model building is described. Chapter 5 contains our model results on the viability of replication of VDSL/FTTC infrastructure as well as deployment of FTTB/H PON and Point-to-Point infrastructure for a selection of six European countries: Germany, France, Italy, Portugal, Spain, Sweden. Chapter 6 contains our conclusions and recommendations.

2 Literature review

This Chapter focuses on an evaluation of recent studies that have been published and that are deemed to be relevant for the specific issue in question. Subsequently, we give a short overview of the main issues addressed and the main results of the studies conducted by (in alphabetic order):

- Analysys (2006, 2007a,b),
- Analysys Mason (2008),
- AT Kearney (2008),
- Avisem (2007a,b),
- BIPT (2008),
- ERG (2007a, b),
- JP Morgan (2006),
- OECD (2008a, b).

2.1 OPTA: Business cases for broadband access

2.1.1 OPTA: Business case for sub-loop unbundling in the Netherlands

On January 24, 2007 OPTA fundamentally revised its proposed previous position on KPN's All-IP project following a study by Analysys (2007a) on the business case for alternative operators using sub-loop unbundling from street cabinets. The study concludes that the threshold for economic viability for an alternative operator using sub-loop unbundling from street cabinets is unlikely to be achieved by any alternative operator unless:

- it reaches a significant market share (in a market that is characterised by major presence and strong market position of cable networks) or
- can operate on the basis of sub-loop unbundling very selectively whilst having a larger global broadband market share than Dutch alternative operators currently control, and
- under the assumption of considerably increased average revenue per user.

Key results of the Analysis study for OPTA are:

- Based on the interconnect and wholesale offers from KPN prevailing at the time of the study, the use of SLU by an alternative provider is not economically viable

as an alternative to continuing to use LLU, except under certain (very favourable) conditions.

- A business case for SLU with similar economic viability to that of continuing use of LLU for 60 % of the population would require both:
 - a market share greater than 55 % of all broadband lines (including cable) in areas served,
 - the highest estimate for incremental revenue (increase in ARPU across all broadband users of EUR 10 per month by 2016).
- For an alternative provider with a 10 % market share of all broadband lines in areas served, it may be economically viable to deploy SLU to around 1,000 of the largest street cabinets in dense urban areas (out of a total of around 28,000 street cabinets in the Netherlands), provided that:
 - the interconnect and wholesale tariffs from KPN for SLU line rental, collocation and links to the street cabinets are reduced significantly (tested 50 %),
 - an increase in ARPU of around EUR 9 per user per month can be achieved for the entire period (which is considered reasonable if business customers are targeted).
- The strong local economies of scale effects that are evident in deployment at the street cabinet level mean that even if such significant cuts of 50 % in KPN's interconnect and wholesale tariffs were to be realised, the use of SLU would still not be economically viable as an alternative to LLU to reach the mass market, unless it is assumed for example:
 - a market share of 25 %, together with the medium estimate for ARPU increase,
 - a market share of 16 %, together with the highest estimate for ARPU increase.
- The current offer from KPN for WBA is also unlikely to be economically viable as an alternative to continuing to use LLU to reach the mass market regardless of the market share, even with the highest estimate for ARPU increase.
- Should OPTA wish to influence the prices offered by KPN to make the SLU option more viable, the prices which affect the viability of an alternative operator's business plan the most are those for the line rental, SDF collocation and SDF-MDF link.

- Furthermore, the assessment of the cost of building a competitive network to provide backhaul to street cabinets indicates that unless very substantial revenue streams can be generated from services other than SLU backhaul, then it will not be possible for a third party to provide such backhaul at prices at the same level as, or below, the current (voluntary) offer from KPN.

2.1.2 OPTA: Business case for fibre-based access in the Netherlands

In complementing its analysis on the economics of sub-loop unbundling or the roll-out of VDSL by alternative operators, OPTA has just recently published a report¹ on the economics of FTTH in the Netherlands. The report examines basically two fibre roll-out scenarios:

- KPN deploys a wide-scale FTTH network to 60% of all households;
- alternative operators offer fibre-based services using fibre LLU (FU) at the Metro Core Locations of KPN and/or WBA (wholesale bitstream access).

The KPN roll-out scenario is based on a P2P Ethernet topology with two fibres laid to each home, one for broadband and one for analogue TV. The topology choice is not further motivated but just referred to similar topology roll-outs of some fibre projects independent of KPN like the City of Amsterdam.

The study finds that KPN can profitably roll out a P2P fibre network for 60% of the Dutch population under three essential assumptions which define the break-even point:

- KPN is facing a duct cost of 30 € per metre.
- The incremental monthly net revenue² per retail subscriber amounts to 13.4 € per month.
- KPN can maintain a 60% market share of the total broadband customer base (45% retail customers, 15% wholesale customers).

A duct cost of 30 € per metre seems to be rather low compared to the level of 50 -120 € per metre in the countries we consider in this study in chapter 5 but the conditions of deploying fibre³ seem to be rather attractive in the Netherlands justifying such a low

¹ See Analysys Mason (2008).

² Net ARPU is defined as total ARPU net of any TV outpayments. Incremental ARPU in this context means revenues over and above the revenues currently received for broadband services provided via ADSL.

³ In the Netherlands micro ducts are installed in the pavement (or in the smaller roads) just underneath the paving stones in the sandbed without any trench, thus the paving stones are picked up, the ducts are simply scratched into the sandbed, the stones are layed back, all in a rolling road work manner.

level of installation costs. If duct costs even drop to 20 € an incremental ARPU of less than 9 € would be needed for a positive business case. At a duct cost of 45 € KPN breaks even at about 20 € incremental monthly revenues. The business case appears completely unviable at 100 € duct costs per metre. The study does not provide sensitivities with regard to market share.

The initial investment for the KPN P2P fibre roll-out are estimated to be 2,088 € per subscriber and 1,566 per home passed. A smaller scale FTTH deployment limited to very densely populated areas and/or mainly to large multi-dwelling buildings would require lower incremental revenues to become viable.

Without further deriving or calculating this result, Analysys assumes that alternative operators currently engaged as (copper) LLU providers cannot replicate KPN's FTTH roll-out. The cost for deploying FTTH on their own are assumed to be prohibitive. To stay in the business two options for alternative operators are considered by which they also can offer fibre-based services:

- setting up a network based on an unbundled fibre product purchased from KPN,
- purchase of a fibre-based WBA from KPN.

For the first business model the alternative operator purchases an unbundled fibre loop at KPN's Metro Core Locations. The price of the fibre loop is calculated on the basis of KPN's relevant costs as derived from the FTTH roll-out described above. On the basis of 30 € per metre for duct costs, the monthly cost of the unbundled fibre loop amounts to 17.99 €. This figure is the key input figure for the alternative operator's business case. Figure 1 represents the results for five different geotypes or clusters. They are ordered by line density, a similar approach as we have taken for deriving our own modelling results in this study. Figure 1 represents all costs of an alternative operator in the access network; they include CPE, line rental, co-location, active equipment, and backhaul to the core network. Core network costs have been excluded; furthermore, only voice and broadband services are produced. For comparison the sub-loop unbundling case producing VDSL is included.

Figure 1: Average monthly cost per subscriber per genotype for the base fibre case scenario in the Netherlands

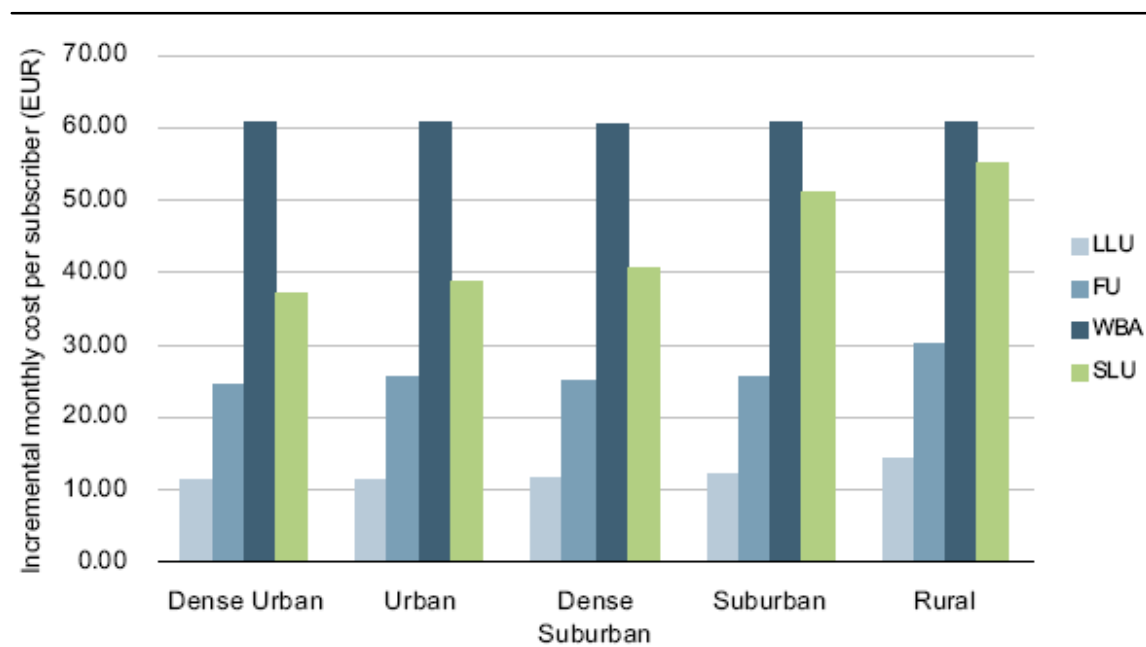

Source: Analysys Mason (2008)

The difference between the cost for (copper) LLU and the cost for the other options provides an indication of the monthly incremental revenue that are necessary to cover the incremental cost of that NGA roll-out option. For fibre unbundling (FU) the additional revenue (or costs) amount to approximately 14 € per subscriber and month in urban areas. This number would increase to 17 € if the alternative operator were to offer analogue TV besides voice and broadband. This number is close to the incremental revenue KPN needs for its viability.

Therefore, a fibre LLU based approach seems to be viable. The WBA option looks totally unviable, requiring incremental revenues of 49 € per month. This surprising result is due to the high WBA charges for high access speeds (36.32 € per month for 100 Mbps) in KPN's current reference offer. Only if these prices were reduced significantly, the WBA option could compete with FU or if the alternative operator would offer lower speeds for WBA (which is offered at a lower wholesale price). Another interesting result, which fits quite well with our own result in this area, is that FU does not appear to be subject to strong economies of scale like those for SLU/VDSL.

A FU based business is facing fewer fixed costs than a VDSL business model. Lower fixed costs have two implications: alternative operators need a lower market share for viability and/or the cost per subscriber does not significantly increase in areas of lower density. The business case of the alternative operator has been calculated for a market

share of just 10% of the covered area of 60% of all households resulting in an effective market share of 6% of the potential customer base in the Netherlands.

2.2 Comreg: Business case for sub-loop unbundling in Dublin

ComReg commissioned Analysys (2007b) to investigate the business case for sub-loop unbundling (SLU) in Dublin. The purpose of the study was to determine whether the business case for SLU is likely to be commercially attractive when compared with local loop unbundling (LLU). The study (published December 20th, 2007) compared the network cost of SLU downstream⁴ of local exchanges with that of LLU. More precisely, the modelling focused on those 37 local exchange areas in Dublin where eircom announced to roll out FTTC. Therefore, the model was set up to reflect as closely as possible eircom's actual network in the Dublin area. This reflected the assumption that if SLU was not commercially attractive in the Dublin area it would be unlikely to be attractive anywhere in Ireland.

Because the model only considers the network cost from the local exchange to the end-user the comparison could not be conducted on a stand-alone business case basis with total cost and revenues. The revenue side was reflected by incorporating the additional revenue a SLU model could yield compared to the LLU case. Results of the model show the average cost per line of SLU and LLU.⁵ The study detailed a base case and conducted sensitivity analysis on key parameters⁶. An optimistic scenario was developed to complement the base case.

⁴ In this context downstream implies the network from the exchange to the end-user.

⁵ More precisely, the average cost per line is the Net Present Value (NPV) of the net costs per subscriber. These are calculated by subtracting the NPV of incremental revenues from the NPV of costs and dividing the result by the number of subscribers.

⁶ Market share, size of cabinets targeted, additional revenue from SLU, broadband penetration, costs of eircom's wholesale services.

Figure 2: Average cost per line - base and optimistic scenario for SLU compared with LLU⁷

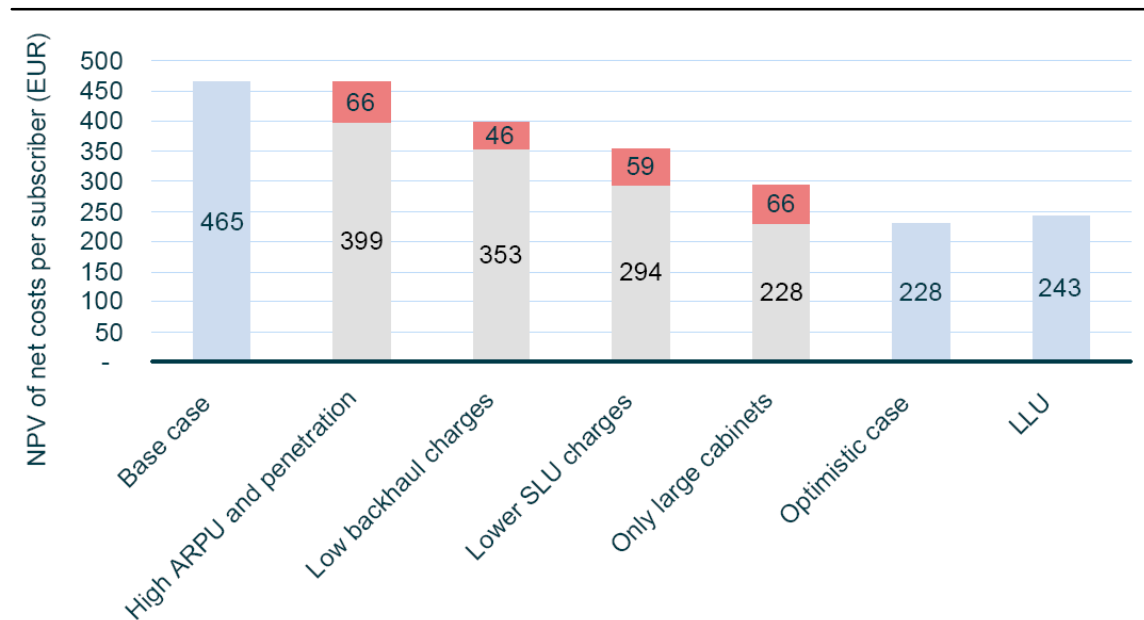

Source: Analysys (2007b), p. 3

Analysys used various sources for the parameters of its model: An initial round of interviews with Irish alternative operators and the incumbent was conducted. eircom provided data on location of exchanges, street cabinets and numbers of lines as input. Furthermore, current Irish pricing for collocation and backhaul was used. For other data Analysys relied on previous work conducted for OPTA, the Dutch reference offer for collocation and backhaul as well as further estimates.

The key findings of the study are:

- Under the base case, SLU is not as commercially attractive as LLU, even when the competitor concentrates on large street cabinets (more than 300 lines).
- The SLU case becomes attractive only under the conditions of an optimistic scenario.⁸
- SLU is subject to very strong economies of scale which are more important for SLU than for LLU.

⁷ The red blocks represent the cost savings compared to the previous scenario.

⁸ The conditions are: significant reduction of SLU costs, high incremental revenue from SLU over LLU, deployment only at large or medium street cabinets.

- The largest costs are the line rental charge for SLU, costs for the street cabinet and the backhaul link to the MDF. The study concludes that it is unlikely that competitors will deploy their own network based on SLU and offer wholesale services. Otherwise stated, it is unlikely that competition will bring about a lower price level than the current one by eircom. This, in turn, underlines the importance that the regulator steps in and sets a fair price.

The study recommends to

- Remove barriers to SLU deployment;
- Review component prices of SLU;
- Introduce flexible NGN bitstream access;
- Ensure sufficient collocation space in eircom's street cabinets;
- Ensure availability of an affordable fibre based backhaul product from eircom.

2.3 BIPT: The business case for sub-loop unbundling in Belgium

Just recently the regulatory authority in Belgium, BIPT, published a business case for sub-loop unbundling in Belgium⁹. It was conducted by Analysys Mason. Background for this study has been the VDSL roll-out plans of Belgacom¹⁰ comprising the intended closure of 65 Local Exchanges¹¹. Similar to the Irish study (section 2.2) the business case compares the well known Local Loop Unbundling business and a future Sub-loop Unbundling VDSL business.

The model results yield that SLU is commercially not that attractive as LLU for an alternative operator under the current market conditions and especially without any regulatory intervention for backhaul and collocation at the street cabinet.

The key finding is that a viable business case can be constructed only under a set of conditions:

- The alternative operator restricts its SLU roll-out to the biggest 50 Local Exchanges representing the densest 30% of the Belgian population;
- The backhaul links to the MDFs are rented from the incumbent (Ethernet based), because duct rental was not sufficient;
- (Physical) collocation at the street cabinet with the incumbent;

⁹ See BIPT (2008).

¹⁰ As of today (September 2008) Belgacom is already at 65% VDSL population coverage.

¹¹ According to the study Belgacom has ~ 1,000 MDFs and 30,000 street cabinets.

- A market share of 20% of the copper lines in the area covered;
- ARPU increase of ~ 13 € per month for triple play per SLU compared to double play per LLU¹²,

Figure 3: Impact of the different network deployment choices and scenarios on the incremental monthly ARPU necessary to cover the additional cost between SLU and LLU

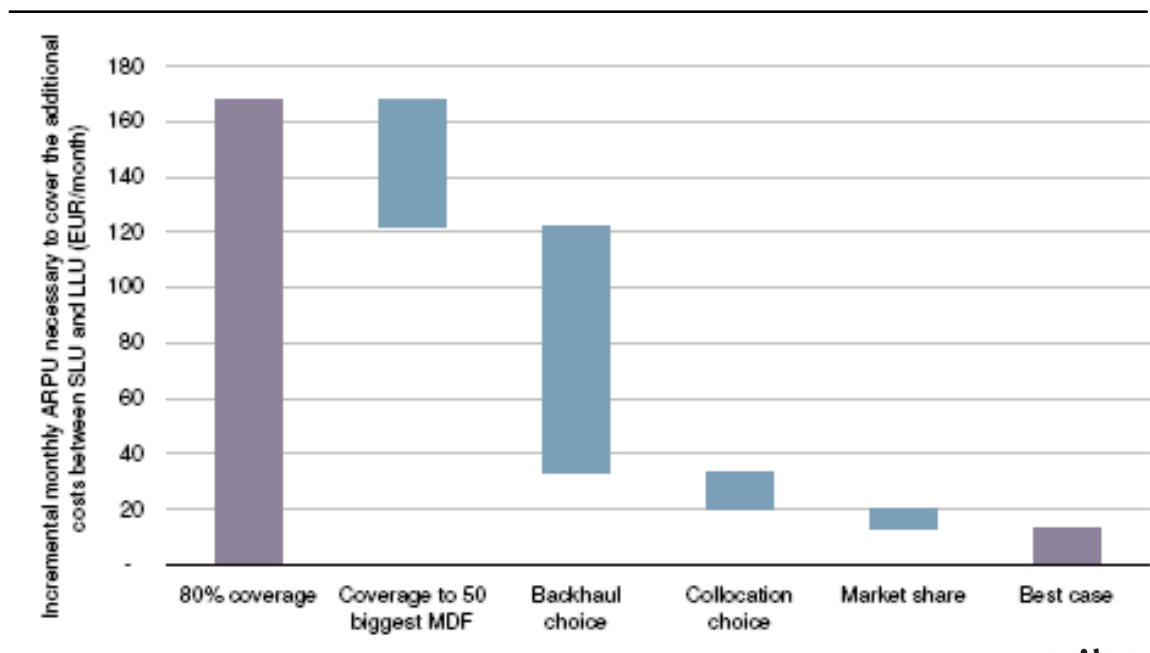

Source: Analysys Mason in BIPT (2008), p.15

The column “80 % coverage” on the left hand side of this figure is the benchmark. It refers to an alternative operator that would theoretically try to replicate Belgacom’s business model (i.e. reaching coverage of 80% of the population in Belgium, using a “build own” option for backhauling and using a “build own ROP (Remote Optical Platform)” option for installing its equipment). Under this scenario, Analysys Mason assumed that the alternative operator would have 50% of the total alternative operator market share. Under these assumptions Analysys Mason calculates the incremental ARPU necessary to cover the additional costs between SLU and LLU at EUR168 per month (which of course is not realistic under prevailing market conditions as Analysys Mason correctly points out).

¹² It is assumed that via LLU only double play services (voice and broadband internet) can be served, while with SLU and its higher bandwidth also TV services can be offered.

The columns to the right show the relative impact of each of the aforementioned factors of coverage, backhaul, co-location and market share on the incremental monthly ARPU necessary to cover the additional costs represented by the SLU model over the LLU model. Thus, in the best case scenario the operator would need an incremental ARPU of around 13 Euro to cover the additional costs of his VDSL roll out.

2.4 Analysys: Fibre in the Last Mile

Analysys (2006) has constructed a simple generic model of ROI for an operator in a so-called typical Western European market of 10 million households.

Assumptions

In this model it is assumed that the incumbent builds out new access networks to 60 % of households in large towns and suburbs over a four-year period. To this end, the incumbent deploys either FTTP (GPON) or VDSL 2 networks.¹³ Analysys assumes that in year 0 broadband penetration stands at 40 % of households and that it will rise to a saturation point of 75 %. The study focuses on four different demand scenarios. For year 0 it is assumed that the telco copper and fibre accesses account for 80 % of all residential broadband, the rest being cable. The market share of telcos in the residential broadband market over time is calculated endogenously in the model and varies across the different access technologies.

Analysys assumes that a VDSL 2 roll-out will require 300-400 Euro investment costs per home passed. This cost level compares to around three times higher investment costs for FTTP at about 1,000 Euro for a GPON deployment approach. The most significant cost factor for FTTP is not the physical length of the trenches but the method chosen to deploy the fibre (aerial vs. new underground). Analysys assumes that the VDSL investment costs are consistent with the investment plan announced by Deutsche Telekom, which will, however, fall at the lower end of the cost spectrum.

Scenarios

The study is based on four scenarios comprising two dimensions (with two qualifiers for each dimension):

- Demand characteristics in the consumer market (receptive, resistant),
- Competition in the pay-TV market (more, less).

¹³ For the sake of comparison Analysys also considers a third case, namely, the incumbent leaves the ADSL access lines in place, thus, taking into account that he does nothing with regard to NGA and therefore is incurring losses.

Scenario A, thus, is characterized by a receptive consumer market and a less competitive TV market. Scenario B is characterized by a resistant consumer market and a less competitive TV market. Scenario C is characterized by a receptive consumer market and a more competitive TV market. Finally, Scenario D is characterized by a receptive consumer market and a more competitive TV market.

The best-case scenario for a telco (scenario A) is characterized by a strong take-up of multi-play services across the operator's user base. However, for such an outcome to be achieved, it is necessary to assume (1) a relatively weak pay-TV market and high prices that can easily be undercut; (2) no regulatory barriers for a dominant telco incumbent to provide media services; (3) the operator has sufficient access to premium content; (4) an audience that is open to demand TV services from telcos. A worst-case scenario (scenario D) is defined by a competitive pay-TV market and a resistant consumer market. Overall consumer demand in this scenario is low and the pay-TV market is already near saturation.

Results

Only in Scenario A, where consumers are receptive to new services and where the pay-TV market is not competitive, does FTTP start to pay back within 20 years, achieving break-even in year 15, see Figure 4. In this case FTTP roll-out has a positive NPV of 29.4 % of the cumulative investment after 20 years (where the discount rate is set at 8 %). This pay-back time depends on ARPUs growing from 17 to 25 Euro over the period.

In all other scenarios there is no positive NPV after this time. The pay-back of a VDSL roll-out could be 7 years earlier than in the FTTP scenario (8 instead of 15 years) and at a 39.4 % NPV of the cumulative investment after 20 years, see Figure 5. The model compares these results with the scenario that the operator does not invest in these technologies and continues its ADSL/ADSL 2+ business, thus losing customers to the existing cable operator(s). The point at which FTTP losses are less than doing nothing is reached in year 11.

Figure 4: ROI on FTTP deployment

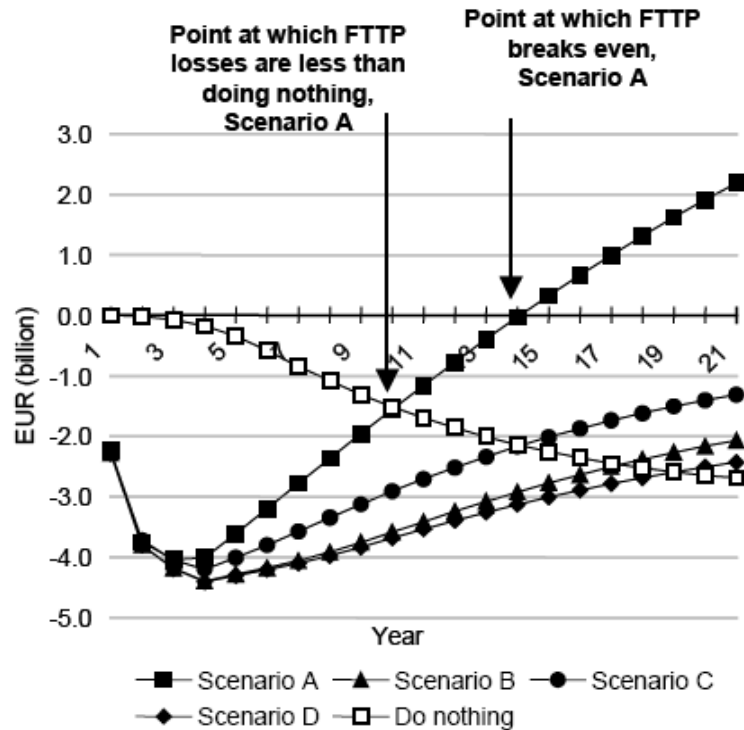

Source: Analysys (2006)

The model results are mainly relevant to an incumbent’s investment decision-making process in an environment where cable presents a competitive challenge.

The study argues that no Western European market looks ideal for widespread FTTP roll-out in the near future. However, it is claimed that the French market comes closest to scenario A and therefore closest to a viable FTTP rollout. Only scenario A justifies an immediate fibre rollout.

Overall, the report concludes that in most circumstances VDSL looks to be a sensible option at least within a timeframe of ten years.

For VDSL roll-out, the Analysys model shows that pay-back time could be achieved in year 8. In all scenarios the model forecasts pay-back within 14 years, a timescale comparable with that for FTTP in the most favourable scenario.

Figure 5: ROI on VDSL deployment

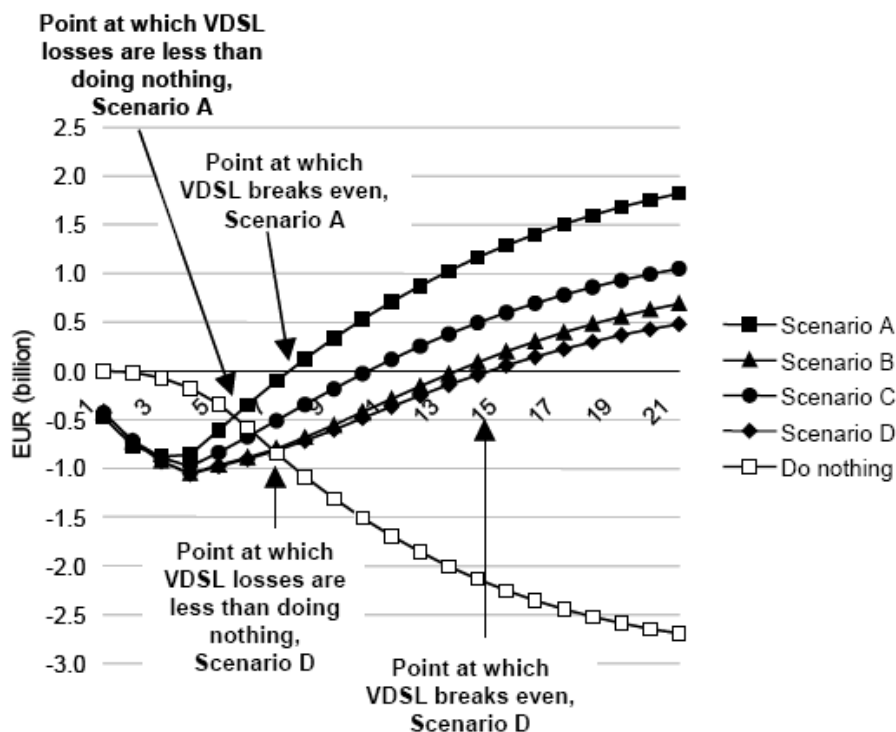

Source: Analysys research (2006)

2.5 Avisem studies for ARCEP

The French regulatory authority ARCEP has identified three major issues for FTTH deployment which are: (1) access to France Telecom’s civil engineering facilities, (2) sharing of the terminal part of FTTH and (3) intervention of local authorities as facilitators. ARCEP has commissioned studies from Avisem for the second and third issue. These studies are focused on urban and suburban regions of France where it is more likely that FTTH deployment will take place. It addresses technical feasibility of FTTH deployment while it does not consider legal issues such as property rights or restrictions on rights of way.

2.5.1 Sharing of the terminal part of FTTH

Scope

Avisem (2007a) considers how existing infrastructure could facilitate the entry into buildings for FTTH/FTTB. It describes the technical options for getting inside a building via eight different infrastructures and it evaluates the feasibility of leveraging them to install fibre access to the building. The infrastructures considered are those for supply of electricity, France Telecom infrastructure, cable TV, waste and fresh water infrastructure, gas, community heating, and street lighting. The study elaborates on five different methods of access to the building which are underground, overhead, façade, mix of overhead/underground and mix of underground/façade. In addition it differentiates between single family homes and multi-dwelling units. The study focuses on fundamental technical feasibility considerations and suggests measures to increase the ability for leveraging the analysed infrastructures. However, the study does not directly address the economics of utilizing each of the infrastructures.¹⁴

Results

- Utilizing ducts and other facilities of France Telecom's network bears high potential. The study addresses duct sharing, underground chambers and further assets such as pole infrastructure. However, at the time of completion of the study, a commercial offer existed only for duct access. Otherwise stated, no offer was available regarding access to overhead infrastructures such as poles, to manholes independent of ducts and other elements that could be leveraged.
- Elements of CATV networks could also become relevant assets. However, according to the study there has been little agreement with France Telecom (FT)¹⁵ on using the CATV ducts (which are in many cases owned by France Telecom) to get access to the subscriber and even less for ducts between manholes, due to FT's exclusive usage rights clause in the agreements with the CATV companies.
- Electricity networks could potentially be leveraged by sharing the use of poles (possible but with numerous limitations, e.g. currently only 2 operators may share pole infrastructure at a time), by sharing ducts for remote energy management (unlikely due to different problems) and façade mounting (as it is done by a CATV subsidiary of Electricité de France).

¹⁴ The only element of information is provided in the form of selected prices for accessing existing infrastructure (e.g. France Telecom's current duct offer or pricing for Electricité de France's overhead electricity infrastructure for deploying CATV).

¹⁵ The study details that 2/3 of French underground CATV networks have been deployed by France Telecom, using almost exclusively France Telecom's existing assets without the need for further civil works. Only 1/3 have been deployed by independent operators requiring new civil works.

- FTTH deployment via sewage networks is technically possible both in accessible and non-accessible underground drains. In the latter case robots may aid in deploying cables. However, generally installations must address a number of potential issues (such as damages from floating material, deterioration, rodents, pressure...).
- In addition to the requirements of sewage networks, FTTH deployment in fresh water networks requires (among other issues) to circumvent valves, to respect specific deployment rules (e.g. regarding cable material) and to (3) take into account the interruption of water service.
- Exploitation of gas networks can be possible but must respect similar constraints as deployment in fresh water environment (vents, security).
- It appears difficult to use district heating networks for FTTH deployment due to the inherent high temperatures.
- Street lighting does not offer many assets as it does not provide building entry except for underground/overhead transitions to the building front.

The report suggests a number of measures to increase the potential offered by the different infrastructures. Examples include:

- Regarding (overhead) energy network infrastructure (EDF): No a priori and systematic limitation of the number of operators.¹⁶
- Regarding France Telecom or CATV infrastructure: Allow sharing of all relevant infrastructures.¹⁷ Provide municipalities with the same rights to access infrastructure as a telecommunications network operator.
- Regarding façade entry to buildings: Study technical and legal feasibility to deploy fibre attached to existing cabling taking account of the specific types of cables (electricity, telephone, cable TV).
- Regarding water and gas: Encourage the identification of plants that are not in use anymore and which could facilitate FTTH deployment.

¹⁶ The current guide regarding electricity networks (“guide pratique des appuis communs”) limits the number of operators which can have access to a pole to two.

¹⁷ This recommendation relates to the limitations stated above in the sub-section on *Results*.

2.5.2 Intervention of local authorities as facilitators

Avisem (2007b):

- Describes common public civil engineering with regard to types of work, current practice in sharing work (e.g. for jointly deploying water and electricity) and data on the volumes of work conducted in France.
- Describes the cases where deployment of ducts is not suitable (where commercial zones have already been connected, where CATV networks already exist, where accessible underground galleries exist).
- Clarifies requirements to facilitate deployment of a fibre-optic network via public civil engineering projects. In this context different FTTH architectures are described, the selection of number and size of cables is discussed as well as the need for placing manholes / cabinets and the issue of duct dimensioning for a given number of operators. Generic recommendations are issued for deploying ducts and dealing with underground manholes.¹⁸
- Highlights case studies for work done by public authorities with different backgrounds.
- Specifies which elements should be taken into account for civil works and what options exist for deploying ducts, manholes and duct access. Sample specifications are provided.
- Identifies and quantifies the primary cost of deploying ducts together with other infrastructure. These are ducts, manholes and trench-width-extensions (cost depends on allocation of the trench cost to telecom and the other infrastructure).

Table 1: Cost estimates for joint duct deployment together with other civil works according to Avisem

Element	Typical Cost per m
Technical implementation studies	2 Euro
Ducts	3 Euro
Manholes	10 Euro
Trench-extension	10 Euro
Total	25 Euro/ m

Source: Avisem (2007b)

¹⁸ 4 ducts at 30mm or better 40mm internal diameter or a single duct of 110mm diameter at minimum. Ideally 4-6 ducts of at least 60mm of which 2 are of larger type should be deployed.

- Assesses the opportunities and risks of deploying ducts together with other civil works and describes different strategies with increasing proactive involvement by public authorities.
- Describes the approach to implementation through 3 phases (definition, annual planning and concrete handling per civil works site).

2.6 AT Kearney: FTTH for Greece

AT Kearney had been commissioned by the Hellenic Ministry of Transport and Communications to develop its 5-year broadband strategy for Greece. The preliminary results of phase 1 on the development of a strategy for the electronic communications industry in Greece have been published in May 2008 for public consultation¹⁹. The project will be continued by the development of a strategy and the identification of action lines and is intended to end mid July 2008.

The study of potential business models is based on a functional value chain consisting of three stages:

- The first stage comprises the provision of fibre (the passive network), i.e. a FTTH based infrastructure from the homes to central offices is deployed and maintained, ending there behind the Optical Distribution Frame (ODF). In the study this stage is called "Infrastructure Provider".
- The second stage comprises the provision of wholesale access services, e.g. wholesale bitstream access, by operating ONTs and OLTs and aggregating switches/ routers in the customer premises and in the central offices, respectively. This bitstream may be as well aggregated at a level above the central office. In the study the second stage is called "Communication Provider".
- The third stage is defined by the actual provision of services to end users. This stage is called "Service Providers".

These elements are comparable to those being under consideration in Singapore, see section 3.3.

¹⁹ See AT Kearney et al. (2008).

On the basis of an analysis of European fibre deployments, the study identifies three alternative service models which can be distinguished by the degree of vertical integration:

- Business model 1 (“Infrastructure Provider”): In this case infrastructure providers build the dark fibre network and provide it in concession to a communication provider. The Communication provider operates the network and provides wholesale access to the service providers.
- Business model 2 (“Wholesale Provider”): In this case an integrated entity is operating both on stage 1 (Infrastructure Provider) and 2 (“Communication Provider”) of the aforementioned value chain.
- Business model 3 (“End-to-End Provider”): In this case an integrated entity is operating all three stages of the aforementioned value chain.

In the End-to-End provider business model each market player only deploys its own infrastructure and thus a closed network. The study therefore excludes this business model as it is unlikely to be viable in Greece due to the asymmetric competitive situation and the presence of many small operators. The Infrastructure Provider service model seems to be the preferred solution: the Infrastructure Provider offers the dark fibre network in a concession to the Communication Provider, while the Communication Provider is granted an exclusivity period sufficient to achieve investment pay back. The Communication Provider has to offer bitstream as an Open Access product without discrimination. It is assumed that besides the new network the existing copper ULL networks will remain in operation.

Against the backdrop of the different technical fibre based broadband architectures (FTTC, FTTB, FTTH PON and P2P) the preliminary recommendation of the AT Kearney study is for FTTH P2P. FTTC is viewed as the appropriate solution for incumbents based on their existing copper network. FTTB is viewed as offering less bandwidth and future service availability and has to deal with poor copper in-house cabling. It is argued that FTTH PON is better suiting to End-to-End Providers, and that it is less flexible with respect to new services and bandwidth growth. Moreover, it is not that easy to provide unbundling solutions in this architecture, if needed.

The AT Kearney study presents a business case for a single FTTH network, with no other network in place, in particular no competitive cable TV network is considered. The business case considers the densely populated areas of Athens and Thessaloniki in more detail, concentrating there on areas above 1,500 inhabitants/km². The model assumes 100 % new digging and calculates the ducts needed on the basis of the street length density and the average amount of dwellings per house. No fees for the Rights of Way on the public domain have been taken into account. The model assumes the size of the central offices in these areas at 15,000 fibre lines each. The Capex per

subscriber at the end period amounts to 1,311 Euros for the passive infrastructure part, 300 Euros for the in-house cabling and 214 Euro for the active components in the Athens area. In the Thessaloniki area they amount to 975, 300 and 231 Euros, respectively.

On the revenue side, a growing number of broadband connections is assumed: it starts in 2007 with 24.6 % of the residential households and 43.2 % of businesses in Athens and reaches 72.0 % and 89.5 %, respectively, in 2030. The fibre penetration related to covered households and businesses ("homes passed") starts in 2010 with 17.9 % and develops from 36.1 % in 2015 to 47.6 % in 2030. The broadband customers that are not served by fibre access still belong to the copper based xDSL business. For the Thessaloniki area the percentage figures are slightly lower.

The business case only considers a double play product bundle, which is assumed to be charged with a 9 Euro fibre premium and 0.18 Euro for innovative services per subscriber and month compared to the copper business (copper ARPU 40.70 Euro per subscriber and month). These values are assumed to vary over time: in 2030 a fibre premium of 6 Euro is assumed and an increased charge for innovative services of 4.50 Euro per subscriber and month, on top of a copper ARPU of 34 Euros per subscriber and month. The fibre fee will decrease over time from 19 Euro per subscriber and month in 2010 to 17 Euro per subscriber and month in 2030.

In the Wholesale Provider service model (Business model 2) and taking Athens and Thessaloniki together the cumulated unlevered cash flow turns positive in 2026 under the described assumptions. With the entities separated the Infrastructure Provider service model (business model 1) yields cumulated unlevered cash flow turning positive in 2027, while for the Communication Provider it already turns positive in 2019. Variations in the scenarios demonstrate that an increase of 10 % in the fibre penetration shortens the time by one year, sharing existing civil infrastructures and thus reducing costs of digging by 15 % does not really change the time, taking PON instead of P2P under certain assumptions reduces the time by 2 years, but assuming that fibre competition occurs with 30 % of the fibre connections served by other operators increases the time by 4 years.

In high level business cases for smaller cities (down to 40.000 inhabitants and concentrating on denser populated areas) there is no positive cumulated unlevered cash flow until 2030. For these areas, AT Kearney recommends public funding of 1.2 bn. Euro in order to reduce the time for a positive cumulative unlevered cash flow to 2016.

The AT Kearney study concludes with some regulatory recommendations, e.g.:

- A simplified administrative process for obtaining rights of way and a fixed very low fee;
- Regulation of the use of existing public domain infrastructure;
- Introduction of obligations for utilities and others performing civil works to directly install ducts or allow others to do so;
- Definition of “FTTH ready” construction standards for new buildings and obligations to fulfil these and, in addition, introduction of incentives to upgrade existing buildings;
- Introduction of a new high speed market and definition of geographic broadband access markets, considerations of civil engineering infrastructure to be essential facilities, regulation for sharing of infrastructures;
- Regulation of sharing in-house infrastructure;
- Assuring the Open Access principle;
- In an End-to-End Provider model, transparency between the retail and the wholesale part is strongly recommended; in case the operator has SMP the separation of both segments is postulated.

On the basis of the consultancy proposal of AT Kearney the Greek Ministry of Transport and Communications (MTC) released a public consultation paper on its national five-year (Q3 2008 - 2013) broadband strategy in May 2008. The paper focused on two main areas:

- implementing a plan for state-assisted FTTx development, focused on Athens and Thessaloniki (with smaller cities labelled less viable due to higher deployment costs),
- developing a strategy to boost high speed broadband access in rural areas.

Just recently an interministerial committee on public and private sector projects has approved the FTTx project. On September 3, 2008, the Greek Minister of Transport and Communications has outlined the main dimensions of the project:²⁰

- Direct fibre access (FTTx) broadband networks covering two million homes in three regions of the country with maximum connection speeds of 100Mbps or more will be built.
- The total investment is EURO 2.1 bn.

²⁰ See TeleGeography Comms Update, September 4, 2008.

- The partly state-funded programme will be implemented over seven years, with three tenders for private sector companies wishing to build and operate FTTB/H networks expected to be launched in the second half of 2009.

2.7 ERG opinion on regulatory principles of NGA

Following a corresponding consultation earlier in 2007, the ERG (2007a) adopted a Common Position on Regulatory Principles of NGA in October 2007. In this document the ERG has analysed the impact that NGA deployment has on the scope of regulation and the way in which regulatory principles may need to be adapted including an analysis of whether current instruments in the EU Framework for electronic communications are still appropriate to deal with these developments. The ERG highlights that for an effective transition to NGA it is important that NRAs ensure that there is transparency and debate surrounding any planned deployment of NGA networks. The regulatory approach should be developed early to provide the necessary predictability to all market players.

In defining the relevant regulatory approach, the ERG emphasises the principle of technological neutrality and the need for ex ante regulation to address market power and to deliver a competitive environment. Furthermore, in accordance with the European Commission Recommendation on Relevant Markets Susceptible to Ex-Ante Regulation, the ERG confirms that the definition of markets, and the assessment of market power, concerns the supply of the services and products delivered via networks rather than the underlying infrastructure. The principle of promoting competition at the deepest level in the network where it is likely to be effective and sustainable remains relevant for regulation of enduring economic bottlenecks in NGA networks. Infrastructure based competition should be promoted by NRAs where this is practically and economically feasible. This principle also entails promoting service competition in instances where replication of access is not considered feasible. Despite the fact that the pace of NGA development differs across and within Member States, the ERG sees the need to define common regulatory principles as well as clear and detailed guidance in order to positively affect competition in access and efficient investment in general. The ERG explicitly focuses on VDSL and FTTH/B NGA implementation. Thus, cable (as well as mobile broadband) and other alternative wireline and wireless technologies are outside the scope of the ERG's Common Position.

The ERG starts with its view of the economic implications of NGA in general and the replicability of wireline NGA networks in particular. One of the overall conclusions is that the economics of NGA networks are likely to vary across different technologies and different geographies. Different technologies may be deployed in different geographic areas. Conditions will differ greatly among Member States and within different regions of Member States and may also lead to significantly different competitive conditions up

to the need to define sub-national markets. Major factors for the choice of the most effective strategy for NGA deployment are:

- copper local loop and sub-loop lengths,
- customer density and dispersion,
- presence of multi-dwelling units, and
- quality and topology of existing network architecture (number of street cabinets per MDF, availability of ducts).

NGA networks are likely to reinforce the importance of scale and scope economies, thereby reducing the degree of replicability of network infrastructure. As a result, effective competition may increasingly require significant scale in order to compete with incumbents' NGA networks. For the time being, the ERG is uncertain about the relevant minimum scale of NGA operation. Scale requirements may induce natural monopoly features in certain areas of the value chain or the geography. For these reasons a one-size-fits-all approach in regulation does not fit with the NGA challenges and implications in Europe.

Besides scale and costs, the profitability of NGA roll-out also critically depends on the ability of operators to generate higher ARPU for services delivered over NGA infrastructure. NGA investments may be more risky than investments in today's infrastructure because of demand uncertainties. Therefore, deployment strategies and other mechanisms are needed to reduce the degree of systematic risk. The ERG regards promoting competition and predictability by NRAs as the best incentive for efficient investment in NGA.

On the basis of techno-economic scenarios for NGA, the ERG has analysed the implications and challenges of NGA developments to the Regulatory Framework. First of all, the ERG points out the necessity of a clear and transparent view of the intentions of market players for deployment of NGA. The ERG assumes that all relevant information can be requested from operators by NRAs in accordance with Art. 5 Framework Directive.

The ERG expects that narrowband access products will be increasingly replaced by broadband access products such as broadband access combined with VoB/VoIP. Therefore, the (previous) retail markets 1 and 2 may in the future include broadband access if they pass the substitutability test. The 'access to the public telephone network' may even be replaced in the long run by 'access to public electronic communications network'. As a consequence, the access market would be defined without any reference to specific services to be supplied across the network.

NGA might have implications for the definition and analysis of (the previous) Markets 11 and 12. At this point Market 11 was defined as wholesale unbundled access to metallic loops and sub-loops. In line with the Access Directive, the ERG concludes that in a NGA context a local loop can and should be defined as a dedicated line between the

network termination point and the (copper/optical) distribution frame at the first aggregation point. Such a definition would meet a FTTC as well as a FTTB/H NGA scenario. In all relevant unbundling scenarios, alternative operators could get access at the physical level of the transmission medium. Unbundling would become technologically neutral. The ERG assumes that the inclusion of fibre into Market 11 would pass the 3-criteria-test.

Market 12 includes all broadband access services. Today's products are mainly based on ATM/Ethernet over xDSL copper access. Bitstream access on FTTx architectures can provide the same type of services using Ethernet at the access plus backhauling to Ethernet switches at different levels of the network. Bitstream access at MDF or equivalent aggregation nodes may become relevant. NRAs have to decide to include new types of bitstream access to market 12.

The ERG also analyses relevant remedies for various NGA scenarios based on the possible barriers to competition. For a FTTC scenario, collocation at the street cabinet and backhaul between street cabinets and the operators' networks are regarded as bottlenecks.

Relevant remedies or wholesale products in the FTTC scenario are:

- LLU at the MDF: migration paths in case of phasing out of MDFs and continuation of LLU up to this point or in certain geographic areas which are not migrated to FTTC;
- Sub-loop unbundling;
- Collocation at the street cabinet;
- Backhaul services either as an ancillary service to Market 11, as a wholesale terminating segment of leased lines (Market 13) or as a separate backhaul market;
- Duct sharing could be imposed as an ancillary service to Market 11;
- Bitstream access to reflect the new NGA architecture and to allow for the provision of high quality services.

The two main barriers to FTTH/B deployment are civil engineering costs ('horizontal barrier') and in-house wiring ('vertical barrier'). Relevant remedies or wholesale products considered in a FTTB/H NGA scenario are:

- Fibre to be included in Market 11 together with an unbundling obligation in case of SMP;
- Adjustment of bitstream access to fit with the FTTH/B architecture;
- Access to duct sharing as a remedy.

The ERG also discusses competition and regulatory issues in the migration period towards NGA. The ERG indicates that NRAs should actively involve themselves in the transition process and manage the regulatory transition issues at an early phase of development. Before the current access network is replaced by a NGA, it should be clear whether and which (regulated) wholesale services can continue or be substituted by functional equivalents.

2.8 JP Morgan: The fibre battle

The JP Morgan (2006) report analyses the market impacts of incumbents' VDSL (and/or FTTH) deployment. As the main focus, the report presents the challenge for European infrastructure-based alternative operators. In particular, the potential responses of alternative operators are evaluated on the basis of a business model. For that purpose the approach of replicating the incumbents' VDSL deployment and the option of bypassing the incumbent's network with FTTH are analysed, and evaluated against each other. The impact of various regulatory interventions on the cost of NGA deployment are identified and evaluated.

JP Morgan identifies three generic reasons which motivate incumbents to roll out VDSL networks:

- Revenue upside: The direct benefits of VDSL lie in greater speed and reach. Incumbents hope to generate commercial advantage from the superior capability of VDSL by charging a premium over ADSL. IPTV is regarded as the major additional source of revenue. Further revenue upside may be generated if competitors cannot follow so that the incumbents' market share recovers and increases. JP Morgan estimates that about 25 % of the population may be willing to pay a premium for materially higher speeds, estimated at around 10 Euro/month and subscriber. Bringing fibre deeper in the network via VDSL increases the reach or the addressable market for DSL and generates therefore an additional revenue potential.
- Cost savings: The incremental investment of VDSL for an incumbent are relatively low. Running the access network as an All-IP network leads to lower Capex and in particular to lower Opex. Closing down MDF locations once the VDSL network is completed leads to significant windfall profit. KPN has calculated the income from the sale of the MDF locations at 1.0 bill. Euro compared to an incremental investment of 0.9 bill. Euro for a comprehensive transformation of the whole access network to an All-IP network.
- Strategic advantages: The first incumbents' roll-out of VDSL (Belgacom, Swisscom, KPN) was driven by significant cable competition and the motive to defend market share. Another strategic benefit of VDSL would result from the

potential difficulty of LLU competitors to match the incumbent's VDSL approach due to a much less favourable business case.

Assuming parameters "typical for an average European broadband market" the study of JP Morgan calculates the profitability of an incumbent's VDSL business case under the following assumptions:

- The incumbent will upgrade 50 % of the country to VDSL.
- The incumbent has a 61 % total broadband market share: 30 % in the VDSL deployment areas and 93 % elsewhere.
- Size of the premium market: 25 % of the overall broadband market, defined by the willingness to pay at least 10 Euro/month extra for VDSL-based services.
- Customer density is defined by 21 street cabinets per MDF.
- ADSL2+ reach of 60 % in the VDSL coverage area.
- VDSL roll-out investment of 200 Euro/household covered.

Under these assumptions the incumbent would realise a 4.8 % market share gain. Based on 50 % VDSL coverage, the overall market share gain is only 2.4 %. Due to the extra monthly contribution from premium customers and from the customers churned back from competitors, the incumbent would be able to achieve an extra 2.2 Euro of monthly revenues per average customer in the VDSL coverage area. Under these implications the incumbent would face a 7 year payback period of its VDSL investment. These results do not consider the upside due to the closure of MDF locations disabling ADSL.

JP Morgan has also calculated the VDSL economics of an alternative operator on a stand-alone greenfield basis. The altnet would need to invest in fibre backhaul between MDF and street cabinet and in its own street cabinets. An alternative operator with a 40 % market share²¹ would face additional costs (compared to ADSL) of 2 Euro/month and subscriber. The monthly costs for backhaul are 1.55 Euro if no ducts can be used and 0.19 Euro if 100 % of all links are ducted. These additional costs are very dependent on the number of street cabinets related to each MDF. In Germany (factor of 40) they could be twice as high as reported because the street cabinets are much closer to the customer and in France (factor of 10) they would be less than half.

Based on JP Morgan's assumptions, the monthly profit from a VDSL subscriber served by an alternative operator would decline by 2 Euro/month for 40 % market share and by

²¹ This assumption compares to the typical (national) market share of the largest xDSL oldnets of 10 – 15 %.

6.5 Euro/month for a 10 % market share. This means that, even a 40 % market share operator is not able to justify the VDSL investment and to replicate the incumbent's approach profitably and without an ARPU or market share uplift. JP Morgan's overall conclusion is that "unless regulation forces the incumbent to provide access to its street cabinets, the option of deploying a VDSL network of their own may not be available to all or most of the LLU operators active today, implying a serious 'replicability' issue".

FTTH is seen as a 'future-proof' technology, but investment-intensive. JP Morgan estimates that the investment requirement for FTTH is about 12 times that of today's unbundling business models, but only 2.5 times that of a VDSL network. When existing ducts can be used, FTTH investment may not exceed that of a VDSL network by much.

On a worldwide basis, the investments for FTTH are in a range of 500 Euro - 2,000 Euro per home connected. The investment figures are highly dependent on market share, density of population, the need for new in-house cabling and the availability of access to ducts. In a base case of 25 % market share there is only a positive NPV of the business case if the network deployment costs of FTTH can be dropped to 2,000 Euro or less. At a 40 % market share, investment costs would decline to 1,600 Euro. Sharing of 50 % of ducts would reduce Capex from 2,500 Euro to 1,500 Euro.

JP Morgan's overall result and conclusion on FTTH is the following: FTTH is a feasible approach under favourable and supportive local circumstances. "Alternative operators with more than 30 % market share in dense enough urban environments and some infrastructure access or sharing, corresponding to around 40 % of the European population, should be able to achieve FTTH payback periods of 10 years or less, without any revenue uplift, purely by avoiding incumbent wholesale charges." Although FTTH is an expensive proposition, there is, according to JP Morgan, a FTTH business case where alternative operators have sufficient market share and access to infrastructure. Even paybacks of six years are possible without assuming ARPU gains. FTTH therefore (and different to VDSL) represents a feasible but geographically limited response to an incumbent VDSL deployment.

JP Morgan does not expect incumbents to invest in FTTH because that would amount to a costly duplication of existing (copper) infrastructure.

2.9 OECD

The OECD has recently published two reports which are of relevance to this study. In the report "Public rights of way for fibre deployment to the home" the OECD (2008a) highlights the importance of rights of way for fibre deployment. Furthermore, a comprehensive overview on the rights of way regulation in the OECD countries is presented. Policy options are discussed shortly.

A second OECD report (2008b) entitled “Developments in fibre technologies and investment” from April 2008 analyses the use of fibre in long haul, backhaul and access networks in particular. Detailed business models for FTTH are presented and the costs of All-Fibre networks are calculated. These two OECD documents provide useful analysis and viewpoints for the present study.

2.9.1 Public rights of way for fibre deployment to the home

This OECD document prepared for the Working Party on Communication Infrastructures and Services Policy highlights the importance of rights of way for fibre deployment in the access network and access to ducts and poles. Based on a comprehensive overview on the status of rights of way regulation in the OECD countries, the OECD develops recommendations on enhancing rights of way regulation to facilitate deployment of FTTH. In particular, barriers to rights of way which may slow down the pace of fibre rollout in local access networks are examined.

The OECD starts from the presumption that fibre in last mile access networks is a key technology and prerequisite for future high-speed broadband connections. Furthermore, the investment costs for fibre deployment are high because of the cost of civil works to construct ducts. The OECD assumes that one reason for the relatively slow pace of fibre investment in many OECD countries is the cost for rights of way and ducts or poles. From a competition point of view it is important to point out that incumbents can use their existing ducts for fibre, while new entrants usually do not dispose of their own ducts in the access and backhaul segments so that they need access either to existing ducts in towns and cities or they need to obtain new rights of way to construct their own ducts.

Municipalities play a large role in rights of way, but there are a number of other important players, including in particular utilities. For network operators, problems have occurred because municipalities have in some countries considered access to rights of way as a revenue opportunity. In certain cases municipalities have tried to use the granting of rights of way permission as a means to upgrade streets and pavements. A number of utilities often try to leverage their existing rights of way by entering into the telecommunications markets. Some local governments are also directly investing in local access networks on the basis of different business models: they provide dark fibre, from public/private partnerships to offer services or, in some cases, become full service providers.

Every country has legal and administrative requirements which have to be met in order to obtain permission to deploy networks on public property. These requirements may act as a barrier to investment if they slow down investments, make investments more expensive, severely delay investments or act as a disincentive to investment. The OECD document exhibits four main factors to obtain rights of way permission: i.e. legal,

administrative, financial, and regulatory factors which are presented in Table 2. These requirements are presented for 20 OECD countries.

Table 2: Requirements to obtain rights of way according to OECD

Legal Factors	Administrative Factors	Financial Factors	Regulatory Factors
<ul style="list-style-type: none"> • Jurisdiction <ul style="list-style-type: none"> - Municipalities - Other entities 	<ul style="list-style-type: none"> • Procedure 	<ul style="list-style-type: none"> • Compensation 	<ul style="list-style-type: none"> • Duct sharing
<ul style="list-style-type: none"> • Dispute resolution 	<ul style="list-style-type: none"> • Deadlines 	<ul style="list-style-type: none"> • Financial burden 	<ul style="list-style-type: none"> • In-house wiring

Source: OECD (2008a), p. 12

In most OECD countries local governments have authority to manage public rights of way. The way in which these management rights are exercised varies widely from country to country.

Regarding legal factors the OECD discusses the following policy considerations. There is sometimes uncertainty and lack of transparency on jurisdiction and dispute resolution. One way to clarify jurisdiction is to confer jurisdiction for granting public rights of way to the federal/or central government either by prescribing special rules or by giving "code powers" to communication network providers. Where this is not possible for constitutional or political reasons, providing more autonomy to network providers can be useful. In addition, providing the regulator with powers to require the sharing of ducts and conferring full authority to local government to make the ducts of other utilities available to operators would also facilitate the roll-out of new networks and help reduce costs.

In order to secure consistent administrative procedures, it would be helpful to set up a clear roadmap on how to obtain public rights of way permits by creating a centralised information point by using a central web portal. To prevent delay in the application process for rights of way, a system of safeguards is required which ensures that deadlines for decisions concerning permits are respected.

An important factor affecting the access to rights of way is the financial cost of access to and use of rights of way. In several countries public rights of way are not subject to payment. In order to reduce costs in the construction of fibre to the home, the OECD concludes that governments and/or regulators should ensure that any fees associated with using public rights of way should be reduced or eliminated. The rights of way applicants should be subject to a minimum set of obligations for remediation and maintenance.

Regulatory issues: the OECD discusses two main high cost items for deploying FTTH: civil engineering works and in-house wiring. These are considered as bottlenecks restricting the deployment of FTTH. With regard to the in-house wiring, the OECD expresses doubts that there will be more than one rolling out of in-house wiring because of costs, lack of space in cable trays and refusal of property representatives to grant access to more than one operator.

In order to facilitate competing fibre local loops, reduce costs and reduce multiple excavation and other civil works in municipalities the sharing of existing ducts, both those of telecommunications and cable companies, but also those of other utilities, is an important policy requirement. Similarly access to building and sharing of wiring is important to ensure effective competition in the market. In order to enhance the construction of competing local loops, governments and/or regulators could:

- (1) Ensure that existing frameworks for sharing of both incumbent telecommunication/cable rights of way and inside wiring are fair.
- (2) Encourage and/or oblige sharing of ducts and other rights of way both by incumbents and by other utilities that have infrastructure.
- (3) Examine whether it would be feasible to develop a framework that would allow for FTTH providers to have access to the rights of way of existing municipal public utilities (water, sewer, electricity). Such a framework may only be feasible if these utilities are publicly owned.
- (4) Develop a framework to allow for joint construction of ducts that can be shared by potential investors in FTTH. A framework in which municipalities are directly involved would be better in ensuring the success of rights of way projects that are mutually owned.
- (5) Examine the possibility of regulatory measures for facilitating the sharing of inside wiring among operators in multi-dwelling units.

Given the costs associated with the rollout of FTTH, the OECD concludes that regulators and governments should take action to provide new entrants with improved access and to facilitate investment in municipal rights of way. The OECD also requests a fair consideration of aerial deployment of fibre which is considered a cost effective method of deployment. Granting access to existing facilities is an important policy option. Sharing of new civil engineering works can be another relevant option. The use of dark fibre is another possible option. Existing administrative and financial disincentives to invest in fibre should be reviewed to reduce costs.

To sum up, the OECD lists the following measures for improved access to rights of way and reduced access costs:

- Reducing barriers associated with obtaining authorisation for access to and use of rights of way.
- Ensuring clarification of jurisdiction for both granting rights of way and settling disputes and coordination among the public authorities involved.
- Harmonising administrative procedures for access to rights of way and ensuring consistency in the application of these procedures across a country.
- Developing a reasonable system of compensation for access to and use of municipal public rights of way.
- Ensuring that operators investing in ducts are subject to a minimum set of obligations for remediation and maintenance.
- Encouraging and/or obliging sharing of ducts and other rights of way both by incumbent communication companies and by other utilities that have infrastructure.
- Examining the role of public-private partnerships in the deployment of dark fibre and/or third party infrastructure providers for duct sharing.
- Examining the possibility of regulatory measures to facilitate the sharing of inside wiring between operators in multi-dwelling units.
- Developing policies to construct joint ducts by new entrants.

2.9.2 Developments in fibre technologies and investment

OECD (2008b) was authored by Rudolf van der Berg from the Ministry of Economic Affairs, The Netherlands, while he was assigned to the OECD Working Party on Communication Infrastructures and Services Policy. Sub-section 2.9.2.1 relates to technology and network architecture. Sub-section 2.9.2.2 addresses different business models for players in the market and their related investment decisions. Sub-section 2.9.2.3 focuses on the business case model.

2.9.2.1 Technology and network architecture aspects

For the discussion of first mile transmission techniques wireless, hybrid and fibre solutions are considered.

Wireless solutions

The study analyses

- 3G and 3.5G mobile wireless standards: HSDPA (High Speed Download Packet Access) and EV-DO (Evolution Data Optimized),
- fixed wireless standards (WiFi (IEEE 802.11x) and WiMAX (IEEE 802.16)/ WiBro (Korea version)).

All of these solutions need high speed fixed access to their base stations, having cell sizes of less than 1 kilometre when supporting high speed download links for several customers at the same time. This leads to the need of a rather high density of broadband connections in a given geographical area to serve the antennas (e.g. based on fibre, E1 leased line, DSL or microwave radio connections). Thus, virtually a fixed broadband network is needed as a prerequisite for these wireless deployments. As the bandwidth of the radio system is shared between all users its capacity to serve users in parallel is limited, thus, their ability to cover many households as a first line technology is poor compared to fixed lines. The advantages of wireless solutions are seen in their mobility and their capacity for covering rural areas. Wireless solutions therefore are excluded from further considerations.

Hybrid networks

Hybrid networks bring fibre closer to the end customer, compared with the existing PSTN networks, thus, shortening the copper lines and increasing the bandwidth which can be transmitted. The study distinguishes the following technologies:

- xDSL (Digital Subscriber Line),
- cable (coaxial cable for TV-distribution), and
- Powerline (based on electricity networks) solutions.

The advantage of all these solutions is that deployment rests on already existing fixed line networks which are enhanced for broadband transmission.

DSL networks act as point-to-point networks between each end user and the first aggregation point (where the individual wires join together) in the street cabinets. The most advanced VDSL technique can transmit around 50 Mbps down and 30 Mbps upstream, provided the copper line length between the aggregating DSLAM (DSL Access Multiplexer) in the street cabinets and the end customer is less than 450 metres. The maximum capacity decreases strongly and nonlinear with an increasing distance. Thus, it depends on the actual physical access network structure to which degree the networks are meeting capacity needs.

In order to install VDSL technology the existing copper access network must be upgraded by installing fibre lines between the central offices and the DSLAMs, by enlarging the street cabinets' space and by serving it with electrical power and air conditioning for the active DSLAM equipment. However, deployment of VDSL could allow existing MDF (Main Distribution Frame) locations to be phased out if there is no further need to maintain a copper line network beyond the sub-loop. It is foreseeable that a much lower number of new concentration points (metro core locations) are needed, which of course might be installed at previous MDF locations. Thus, overall there is a huge potential for financing the new investment by selling those MDF locations which are not needed anymore. Potential drawbacks identified by the study are that copper line lengths, while reduced, remain a constraint, that there is little room left for improvement towards higher bandwidths and that streaming content (e.g. IP-TV) might consume the downstream capacity, thus, leaving less for other applications.

Cable TV networks inherently are broadcast networks and act as a shared medium. All end customers receive the same information and access the same cable. Thus, in order to enable individual communication the network must be upgraded by electronic transmission systems, which allow the separation of individual upstream communication on a common cable and select the individual downstream information which is spread in a broadcast manner, so that each end customer only receives what is dedicated to him. While the system is ideally suited for TV-signal distribution its capacity for individual communication is limited and depends on the amount of users being active at the same time. For a group of users the study identifies a typical capacity of 160 Mbps downstream (for data communications). To overcome this disadvantage the amount of users on the same cable might be reduced by installing fibre and moving fibre nodes closer to the end customers.

Powerline is mentioned to serve currently up to 27 Mbps downstream and 18 Mbps upstream for a group of users hooked upon the shared communication medium, the same power cable. This excludes IP-TV and therefore triple play product bundles. And even then Powerline solutions will need a more dense fibre access point distribution compared to VDSL. Powerline suffers significantly from electric interference problems (receiving and transmitting), since the power cables are not shielded and were not designed as an electronic communications medium. The study states it to be too early to assess the future role of Powerline solutions in the market and therefore does not investigate this solution in more depth.

Fibre based solutions

The study identifies the following advantages of fibre as a transmission medium:

- capacity to carry nearly unlimited bandwidth,
- low latency (transmission delay) compared with satellite,
- low attenuation and dispersion, thus, low need for signal regeneration,

- good environmental characteristics, e.g. neither influences on the transmitted information by electromagnetic fields nor emission of such fields, thus, no disturbances or crosstalks between neighbouring fibres/wires, no corrosion, no influence from rain, foliage or buildings (line of sight) as with radio networks,
- low weight and size,
- similar price compared to twisted pair telephone or coaxial cables.

The study cites the Arthur D. Little (2006) study estimating the future bandwidth per household to peak at 50 Mbps downstream and 8 Mbps upstream for triple play use (telephony, data and video/TV).

There are two different approaches for deploying a FTTH (Fibre to the Home)²² infrastructure as first mile network:

- Fibre P2P,
- PON (Passive Optical Network).

Both of these technologies are built on fibre only and do not need an intermediate active network node between the MDF/ODF (Optical Distribution Frame) location and the customer premises. In particular, there is no need for an active street cabinet like in the VDSL case.

Compared with copper infrastructure the limitations regarding length are much lower in the case of fibre, and therefore the distance between a fibre ODF (and the necessary Optical Line Termination (OLT) equipment) and the end customer may be much higher. This, in turn, allows concentration of the access network at fewer (metro core) locations and closure of old MDF locations.

With Fibre P2P each subscriber is connected by a dedicated fibre between the ODF and its home, enabling exploitation of the fibre capacity up to the limits the attached terminal equipment allows. State of the art are Ethernet interfaces with up to 1 Gbit/s in a symmetrical manner. Thus, such a non shared solution is future proof according to uncertain bandwidth needs and it is able to serve all kind of end customers, i.e. residential and business as well as wireless operators' antenna and switch locations.

The OECD study points out that with PON typically a group of up to 64 subscribers²³ is addressed by one fibre strand starting at the ODF location. This single fibre strand is transformed into one fibre per subscriber at one (or several cascaded) splitter

²² The study does not mention FTTB solutions, where the fibre termination point is in the basement of a building and where the connection into the actual customer apartments is based on existing in-house infrastructures (like e.g. copper cables).

²³ It is worth to point out that there are of course countries in which the architectures are based upon a 32 subscriber (or even lower) outlay.

location(s). In the splitter the optical beam is distributed into each of the fibres and vice versa, thus all subscribers use the same optical beam for upstream and downstream communications.²⁴ Therefore the beam is the shared medium and the architecture is somehow comparable to CATV. The capacity in the most advanced GPON (Gigabit PON) solutions currently is 2.5 Gbit/s downstream and 1.25 – 2.5 Gbit/s upstream, shared between the subscribers. The fibre strands are terminated at an OLT in the central location and an ONU at the subscriber site. This equipment administers upstream capacity on demand and recognizes the addressee for downstream communication.

The study distinguishes three approaches to locate the splitter (see the next figure):

- inside the user building,
- outside the building in a street cabinet, and
- in the central office.

The study emphasizes that the alternative actually chosen affects the cost of a second operator who intends to use the existing infrastructure in an unbundled way. The most expensive solution for that case is the splitter location in the basement of a building. However, the study neglects to either raise or discuss what location environment or cost factors may be at-play in the deployment decision regarding splitter location or what additional considerations may impact why one approach may be chosen over another.

²⁴ To be more precise, this is not necessarily the only possible case, as some PON architectures utilize more than one (separate) lasers.

Figure 6: Topologies for PON fibre networks according to OECD

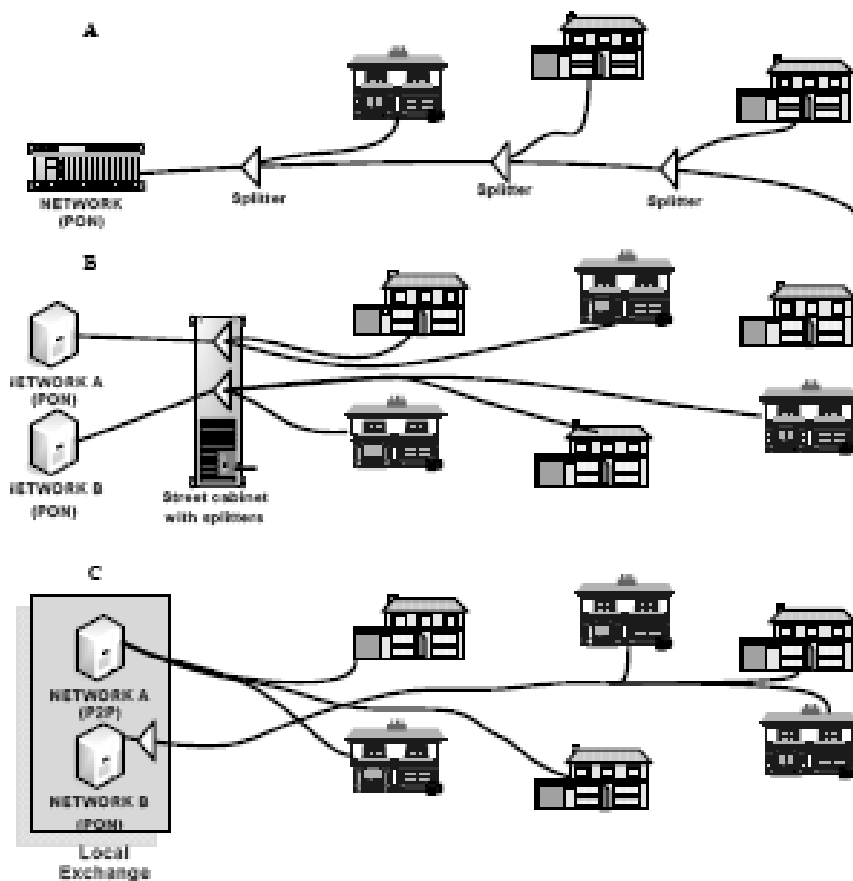

Source: OECD (2008b)

The study points out that both FTTH P2P and PON solutions need fibre for in-house cabling, i.e. they cannot use existing (copper) cabling within the buildings. Thus additional investments have to be made there. However, the study does not distinguish among deployments to multiple dwelling units (MDUs), business complexes or single-family homes, and the fact that existing cabling may in fact be sufficient where distance from the optical terminal to the user connection is minimal.

Some PON networks distribute TV signals in a separate channel, thus, releasing the data communication channels from the TV streaming information.

Comparison of access technologies

Comparing the last mile network solutions the OECD study at first excludes all wireless approaches, because they are “not capable of sending large amounts of data over larger distances and to provide service to many users simultaneously”. Wireless approaches have their strength regarding mobility and with respect to the last wireless

meters in a building and perhaps also in geographical regions with an extremely dispersed population.

Concerning the hybrid networks Powerline is characterized as a niche technology which is therefore not considered further in the study. Cable and VDSL networks are qualified as being able to sustain services for the average user in the coming years. CATV is viewed as performing better in distributing TV signals and VDSL is stronger with respect to providing multiple on-demand streams (e.g. video on demand). Both technologies are classified as not being future proof concerning the bandwidth offered.

According to the OECD, Fibre to the Home networks provide the best performing solution concerning bandwidth and sustainability per end user and are therefore most future proof. The decision between P2P and PON fibre will depend on various preferences and local facts. Both are able to serve the customer needs in a satisfying way. Although the OECD study states that “businesses will have a strong preference for point-2-point networks” (p. 26), it provides no further support for this conclusion..

From a regulatory point of view the study mentions four levels of unbundling:

- Conduit and collocation facilities;
- Physical layer unbundling (e.g. sub-loop unbundling (SLU), copper wire, fibre, optical layer unbundling (xWDM in PON));
- Data link layer unbundling (e.g. wholesale bitstream access);
- Network layer unbundling (e.g. IP Layer 3 services).

Because of their shared nature, CATV and PON networks are inherently less suited to Local Loop Unbundling. With PON the only possibility will be a SLU solution, provided the splitters are accessible. A solution might be if the splitters are located in street cabinets which give access to Optical Street Distribution Frames (OSDF). The OECD report underlines that a PON environment requires unbundling to be “taken into account right from the start of the network” (p. 27). Otherwise stated, such implementations, the need for them, and the relevant costs/benefits have to be anticipated (and/or mandated) from the beginning of the rollout of the PON.

LLU is possible with DSL (practised in many countries) and P2P fibre networks.

Wholesale bitstream access may be implemented on all networks, but it is more difficult on networks with a shared medium (CATV, PON) to guarantee the same non-discriminatory quality for all and maximise the usage of the available bandwidth at the same time. ²⁵

²⁵ Of course, guaranteeing QoS in particular depends largely on the backhaul supplied to CATV and PON.

Likewise, there are several requirements regarding the unbundled transmission of TV signals by Wholesale Bitstream Access:

- Broadcast TV on PON or CATV cannot be shared by different operators unless the possible number of channels is limited for all parties (they are restricted by the number of operators who want to share the limited capacity).
- IP-TV competes with data in the same bitstream, thus, bandwidth must be allocated for the TV-stream. Some agreement on IP-TV multicast as a WBA feature therefore is required. This is less critical in P2P fibre solutions where the capacity to each customer is not restricted.
- If there are sufficient fibre strands available, a separate fibre to deliver Cable TV to the end customer might provide a real choice for the customer between Cable TV and IP-TV offers.

Summing up this comparison there is a preference for fibre based FTTH networks, while there is a clear preference of business customers for the P2P fibre network. From a regulatory point of view there is a preference for P2P fibre networks as well, because they offer more options for regulatory measures like LLU and WBA where these are deemed necessary.

2.9.2.2 Business models and investment decisions

The study analyses several business models and investment decisions from the perspective of both an incumbent and competitors.

Cable operators

Cable operators can migrate to DOCSIS 3.0 and expand the fibre closer to the end customer, thus climbing up the ladder of investment, but they normally have limited free cash flow. These operators act as a second operator unless they are the first mover or refuse to invest at all.

Telco incumbents

Incumbents address the increasing need for more broadband in most cases by rolling out VDSL networks and, thus, bringing fibre closer to the end customer. This limits the investment compared to an all fibre access network. An FTTH network may be a second step to enlarge the fibre reach when the bandwidth demand increase justifies it. This strategy, however, bears the risks that (1) the existing large free cash flow may diminish with falling voice revenues, so that liquidity is reduced when the second step is necessary and (2) a pure fibre network may have a different cost optimal topology than

the reconstruction of the existing copper network by fibre. Moreover, the incumbent may be bypassed by a competitor.

Some incumbents already invest in all fibre access networks, because there is a competitive force by new entrants or cable operators.²⁶ The study does not mention that the national structure of the copper access network may not allow a viable business case for VDSL because of the length of the sub-loop, like in France. Besides this, there is a welcome side effect (from the viewpoint of the incumbent) because the VDSL solution might discourage competitors to further invest in infrastructure and fall back to purchase wholesale bitstream access. This may as well be a welcome side effect for the incumbent when the incumbent deploys PON instead of P2P fibre access lines.

Market entrants

Market entrants may move up the value chain and save LLU charges when they deploy FTTH. A first mover approach may end in high customer penetration, which is crucial in a competitive situation. Citing Analysys (2007a) the OECD study states “that in many cases there will not be a viable business case for new entrants presently using local loop unbundling to move to sub-loop unbundling to invest alongside the incumbent”. The new entrants can neither access the already existing infrastructure of the incumbent nor can they experience the savings of selling existing assets (like the MDF locations). Thus they may take up the chance and the risk of moving ahead of the incumbent.

A special group of new entrants may be utility companies (like e.g. in Denmark). They may try to diversify and leverage the already existing infrastructure. They normally work under less risk and a lower WACC and they are used to make long term investments. Often municipalities use their utility companies as an instrument for an economic improvement of their region by deploying fibre infrastructure.

Alternative business models

The study also discusses alternative business models like

- Welfare based networks,
- Customer owned networks,
- Service and advertisement financed networks,
- Open networks.

²⁶ Examples are the fibre deployments in Korea (Korea Telecom), Japan (NTT East and West) and the U.S. (Verizon).

In “welfare based networks” the indirect welfare aspects caused by the fact that a broadband access network exists help to finance (or subsidise) the network. Such aspects may be energy efficiency gains, having elderly people stay longer in their homes or remotely monitor patients.

“Customer owned networks” are characterized by end customers deploying access network infrastructure on their own risk between their homes and a central concentration point, e.g. a local exchange location, where the service providers are present. Such a business model might facilitate a provider change, increase the choice between all services offered and it might allow a strictly cost based deployment.

With “service and advertisement financed networks” the dream of the network operators would come true to participate from the high income of content providers and their stock value increases. But disruptive technological developments and disruptive acceptance of services may dramatically change such business cases.

“Open networks” may be divided into three layers: passive network, active components and services and content. The passive network and possibly the active components are offered in a non-discriminatory manner to all operators, thus, guaranteeing a high penetration rate. The loss of income from the services may be compensated by a guaranteed income over the fixed lines of all operators. The study indicates that financial investors may consider a premium for operations displaying such characteristics.

2.9.2.3 Business case model

The business case model presented in OECD (2008b) was developed for the Ministry of Economics of the Netherlands. Its empirical basis refers to concrete Dutch regions, construction cost etc.. The results therefore are not directly applicable to other countries. Nevertheless the study describes some cost mechanics which are of interest for the generic approach pursued in the present study. The model is publicly available under <http://ngn.arcadis.nl>.

The model calculates the price per month per household (subscriber) for a triple play service depending on the penetration rate. The penetration rate is defined as the percentage of the number of subscriptions compared to the number of households passed. The results in Table 3 show a strong dependency of the end customer related cost (total) and the penetration rate.

Table 3: Price per household and month, depending on the penetration rate

Penetration Rate	15%	25%	33%	50%	75%	100%	50% at 5% profit	50% at 7.5% profit
Triple Play	22	22	22	22	22	22	22	22
Monthly charge Passive	67.80	40.68	30.82	20.34	13.56	10.17	15.02	17.66
Monthly charge Active	19.44	17.94	17.43	16.91	16.42	16.28	14.83	15.85
VAT 19%	20.76	15.32	13.35	11.26	9.88	9.21	9.85	10.55
Total	130.00	95.94	83.60	70.50	61.86	57.66	61.70	66.06

Source: OECD (2008b)

The investment in passive and active infrastructure is determined by the size of the area, the housing density, the type of houses, cost of repaving and the cost of the active equipment. For the average housing density of the Netherlands the cost of a passive network will range between 500 and 1,500 Euro per household, while the cost of the active equipment is around 750 Euro per household. For the examples given in the annex of the study (see below) the cost of passive infrastructure accounts for 53 % of the capital expenditure.

The results of the model show that there is no large scope for rolling out new all fibre access infrastructures. When two independent operators share the market so that each of them has a 50 % penetration rate (and both together 100 %) the cost per household is 70.50 Euro per month, assuming no sharing of costs between both operators. A monopolistic operator (100 % penetration) could offer the triple play service for 57.66 Euro per month. Thus, the question is what the customers are willing to pay (more) for a competitive situation and how this may influence the penetration rate.

The study concludes that the impact of the penetration rate makes it unlikely to have multiple networks to guarantee a competitive market with four or even more competitors. Thus, supervising regulation must prevent tacit collusion in the market.

In the annex the study applies the model to the population density of Sun City, Arizona, USA. Assuming a penetration rate of 50 % this results in 104.54 Euro per month, compared to the Dutch 70.50 Euro per month, thus, underlining the importance of the population density.

The results of the business case model show that reducing the costs of the passive infrastructure will have a major impact. The study therefore proposes means which can be taken by the government, the municipalities and the regulator to ease the infrastructure roll-out. Examples are:

- common use of in-house infrastructure,
- access to existing infrastructure (sewers, utilities),

- coordinated construction (between operators, utilities, municipalities),
- allowing the roll-out of new networks regardless whether there already exist networks,
- allowing collocation in street cabinets,
- unbundling PON, if unbundling is a regulatory tool,
- enabling to exchange local traffic locally.

The study recommends that the government should refrain from subsidising the roll-out of a network in a region unless there is clear evidence that no private investor will do it. If under these circumstances a network is subsidised, it must be accessible to other networks and service providers under equal conditions as an open network. And even in this case the roll-out of new networks must be allowed, so that no protection or monopoly arises. The network topology chosen should be a P2P fibre network because of the ease of unbundling.

Moreover, the OECD report addresses the issue that local governments bundle their demands for new networks with the demands of companies e.g. to procure a customer owned network or enter into an agreement with an existing network operator. In this case, so the OECD argues, one important condition should be fulfilled: the terms of these agreements should enable competition on the service level and should not grant one operator a monopoly over those participating in the bundled demand.

2.9.2.4 Summary

Summarizing the study one can describe the technology and network architecture best suiting the future needs to be a fibre based first mile network, where P2P networks are better suited for business customers' needs and are also preferable from a regulatory perspective (easier to unbundle). The study recommends P2P fibre therefore also in the case of publicly subsidised networks. Due to the crucial effect of network penetration on the cost per end customer and the influence of the passive infrastructure, the study recommends means to reduce the costs for the roll-out of infrastructure for broadband access networks. Moreover, the foreseeable cost structure of a network owner and, in turn, its pricing opportunities raise the question as to whether, in a given market, facilities-based competition will emerge. The OECD report concludes that for an all-fibre network it is unlikely that there will be multiple networks to guarantee a competitive market. Even if existing cable and PSTN-based networks are factored in, according to the study, it is unlikely that there will be enough room in the market for four or more physical infrastructures to every household. The OECD report therefore underlines that there is a continuing possibility of (tacit) collusion in the market, a development regulators will have to take into account.

3 Experiences in non-European countries

This Chapter focuses on experiences with fibre deployment and utilization, respectively, by market participants in selected non-European countries. Thus, we are concentrating on international experience on replicability and particular regulatory approaches. Developments in the following countries have been analysed:

- Australia,
- Japan,
- Singapore,
- USA.

3.1 Australia

3.1.1 Overall broadband market penetration

Broadband access in Australia currently is offered on the basis of several technologies, see Table 4.

Table 4: Broadband penetration in Australia according to technologies (as of September 2006)

Type of access	Cable	Satellite	ADSL	Other DSL	Other	Totals
No. of subscribers	624,300	42,400	2,763,000	70,500	139,500	3,639,700

Source: ACCC

The table contains figures as of September 2006. The table shows that broadband access in Australia mainly relies on ADSL: Around 2.8 mill. Australian households were subscribing to ADSL. 42,000 households were subscribing to Satellite Broadband. 624,300 households were subscribing to HFC. As of Dec 2007 Australia was ranked 16th out of 30 in OECD penetration tables just behind the US.

3.1.2 Current broadband market structure

Telstra

Since 2006 Telstra and its competitors began to focus on the deployment of ADSL2+ infrastructures. In February 2008, 907 out of the total 2,432 exchanges were ADSL2+ enabled to give approximately 3 million Australian households a theoretical maximum downlink speed of up to 20 Mbps (compared to 2 Mbps ADSL maximum downlink speed). The ADSL2+ roll-out mainly focuses on Australia's most populated State New South Wales.

ISPs with DSLAM infrastructure

Table 5 shows the number of DSL-enabled exchanges that are accessible by competing infrastructure providers.

Table 5: Internet service providers with DSLAM infrastructure in Australia

Service providers with own DSLAM infrastructure	DSL-enabled exchanges 30 June 2006*	DSL-enabled exchanges 31 January 2007*
AAPT	22	22
Adam Internet	25	29
Amcom	34	34
iiNet	245	266
Internode/Agile	47	73
Netspace Networks	na	20
Nextep	na	95
Onthenet	8	8
Optus	100	304
PowerTel	126	130
Primus	182	182
Regional Internet Australia**	6	6
Soul	na	22
Telstra	2,109	2,432
TPG	65	145
TransACT	na	9
TSN Internet	4	4
Wideband networks	1	2
Widelinx	na	3

Source: service provider websites and ACMA targeted data request

*In many cases, multiple carriers have DSL available from the same exchange – therefore, the figures should not be added to infer a total number of exchanges with DSLAM infrastructure.

** Regional Internet Australia was placed in administration in April 2007.

na: not available

Table 5 shows that Telstra's competitors Optus (304 exchanges), iiNet (266), and Primus (182) have the highest number of DSL-enabled exchanges. In Australia 459 exchanges are served by more than one infrastructure provider, thus, enabling many customers to have access to two or more broadband providers. This kind of competition is predominantly based in the capital cities of Adelaide, Brisbane, Canberra, Melbourne, Perth and Sydney.

Regional FTTB/H projects

Limited FTTH or FTTpremises projects have been planned in several Australian States, usually in greenfield developments. According to ACCC the most relevant of these initiatives are being pursued by state governments. These are²⁷:

- The Queensland Government has initiated a project called "Vista", which aims at bringing a 100 Mbps broadband service to Brisbane through deployment of FTTH technology. The project is estimated to cost A\$550 million and is scheduled for rollout in late 2008.
- The Victoria Government has developed the "Aurora" project, which plans to deliver FTTH broadband services to approximately 8,000 residents in the Aurora estate in Melbourne's northern suburbs. Residents will be offered voice telephony, data and video services over the network, including pay TV, free-to-air television and the emerging video-on-demand (VOD) services.
- The Tasmanian Government is pursuing the "TasCOLT" project, which is a pilot project with aerial fibre cabling using new-generation passive optical networking technology. The project was launched in late 2006 and aims to cover wide areas of the Tasmanian island.

Wireless Broadband Access

In late 2006 approximately 204 companies offered wireless services.

Satellite Broadband

Satellite broadband services provide 100 per cent coverage of Australia's land area. In April 2007, there were around 41 satellite broadband service providers operating in Australia. Most of these service providers are regional ISPs that resell satellite broadband to regional, rural and remote customers.

²⁷ See ACCC (2007): Communications Infrastructure and Services Availability in Australia 2006-2007, p. 11.

Hybrid Fibre Coaxial Cable

There are two major HFC networks in Australia, which are operated by Telstra and Optus. Telstra's network passes 2.5 million homes in Adelaide, Brisbane, the Gold Coast, Melbourne, Perth and Sydney. Optus' network is capable of servicing 1.4 mill. homes in Brisbane, Melbourne and Sydney. There is a considerable degree of overlap between these networks, resulting in an estimated combined coverage of 2.6 million homes. Telstra uses its HFC network for television and broadband services, as does Optus, which also uses HFC for voice telephony services.

3.1.3 Envisaged nationwide "Fibre to the Node" network

In late 2005 Australian fixed line incumbent Telstra issued a plan to build a nationwide Fibre to the Node (FTTN) network.²⁸ In view of this plan alternative operators and Internet Service Providers in Australia responded that this new incumbent network would lock out all competitors, and would only provide bandwidths already available with the existing infrastructure.

At the same time a group of nine operators, comprising Optus, AAPT, Internode, iiNet, Primus, Macquarie Telecom, Powertel, Soul and TransACT formed a consortium called G9 to build an alternative open network which, with Telstra's participation, would have covered a larger percentage of the population and allowed open competition. The consortium estimated the total cost of the rollout at A\$ 4.1 bn. (Euro 2.6 bn.), one billion more than Telstra's proposed cost for its high-speed network.

In spring 2006 Telstra refused to participate in the G9 consortium and due to regulatory issues abandoned its original plans to build a nationwide network on its own.

In December 2006 the G9 consortium announced their intention to invest in an own FTTN network without participation of Telstra. Therefore the consortium lodged a special access undertaking regarding pricing policy with the ACCC in June 2007. However, in late 2007 the ACCC rejected G9's plan, due to perceived absence of 3rd party providers competing with the G9 group.

²⁸ Fibre to the Node (or Fibre to the Cabinet) is a fibre optic based telecommunications architecture. The optical fibre runs to a street cabinet.

To solve this situation the Australian Government released a new Request for Proposals (RFP) for the roll-out of a (new nationwide) National Broadband Network (NBN) in April 2008. The RFP details the scope of the NBN, which will²⁹:

- deliver minimum download speeds of 12 Mbps to 98 % of Australian homes and businesses;
- have the network rolled out and made operational progressively over five years using fibre to the node or fibre to the premises technology;
- support high quality voice, data and video services including symmetric applications such as high definition video conferencing;
- earn the Commonwealth a return on its investment;
- facilitate competition in the telecommunications sector through open access arrangements that allow all service providers access to the network on equivalent terms, and
- enable uniform and affordable retail prices to consumers, no matter where they live.

The Australian Government has committed to spend up to 4.7 billion AUD (approx. 2.9 billion Euro) to enable the rollout of the nationwide broadband network, because “the new network will change the way Australians communicate and do business, and demonstrates the priority this government is giving to building Australia’s future³⁰”.

There are two parties which have so far lodged a bid (as of June 2008)

- Telstra,
- G9 (meanwhile renamed as Terria).

Telstra and G9/Terria have submitted their respective bids in May 2008.

There are, however, several other parties who have announced publicly an interest to bid. One of these potential bidders is a consortium named Acacia led by private businessmen from Melbourne. Another potential bidder was a consortium led by the Australian infrastructure investment focussed Macquarie Bank which announced interest in participating in the RFP in May 2008. The consortium was supported by three former Telstra senior executives. However, on June 23, 2008 it was reported that

²⁹ See http://www.minister.dbcde.gov.au/media/media_releases/2008/023.

³⁰ http://www.minister.dbcde.gov.au/media/media_releases/2008/023

Macquarie has joined the Telstra consortium acting primarily as Telstra's financial advisor.³¹

Several issues are key in the Australian discussion surrounding the NBN:

- *Financing*: The Ministry estimates the total costs of the network at 8-9 billion AUD (4.9-5.5 billion Euro). Telstra estimates a total investment of up to 15 billion AUD (9.2 billion Euro). The incumbent Telstra claims that the rival G9/Terria consortium would not be able to build such a nationwide network, due to the lack of financial resources.³²
- *Access to information about the existing network*: G9/Terria are criticizing Telstra for abusing its monopoly on existing network information while not sharing network information with alternative bidders.
- *Structural separation of the entity deploying and operating the NBN*: Telstra is underscoring that it sees no rationale for any form of separation should it win the bid. G9/Terria, however, are calling for separation of the entity which is responsible for the establishment and operation of NBN. G9/Terria are accusing Telstra of attempting to re-monopolize the fixed network segment. G9/Terria, are emphasizing the principle that the NBN "should not be majority owned or controlled by any one retail telco. If Telstra is to build the network, it must accept the same principle."³³ In this context it is worth to mention that G9/Terria is offering to parties across the industry, including Telstra, to co-invest in building the NBN and to establish a competitive regime.

The party to build the National Broadband Network will be selected through a competitive assessment process. The government aims to announce the successful bidder in late 2008.³⁴

³¹ See Communications Day, issue 3300, June 23, 2008.

³² Some background information in this context is useful. Telstra owns most of the national network infrastructure. Analysts from ABN Amro in Australia argue that Telstra had already planned to invest A\$ 4.1 bn. in a broadband network. This investment, would make it possible for Telstra to reach roughly 5 mill. of the 9 mill. households in Australia. If the A\$ 4.7 bn. contribution of the Australian government was added, so the argument continues, Telstra might be enabled to reach about 7 mill. households (if Telstra still invests its A\$4.1 bn.). ABN Amro estimates the total costs to get close to the required 98 % of the population at A\$ 12 – 15 bn.. Furthermore, they refer to a study by Ericsson, claiming that it would cost 50 times more per person to provide coverage to the last 10 % of the Australian population than it would cost to cover the first 88 %. See Groenewald (2008).

³³ Optus CEO O'Sullivan; see Communications Day, issue 3290, June 6, 2008.

³⁴ http://www.dbcde.gov.au/communications_for_business/funding_programs_and_support/national_broadband_network. Actually, there are three separate evaluations with different deadlines. Submissions on NBN regulatory issues are due June 25, 2008. Submissions on broadband solutions for remote areas are due by June 30, 2008. Regulatory submissions will be considered by a "Panel of Experts" while submissions on broadband solutions for remote areas will be considered by the Regional Telecommunications Independent Review Committee (RTIRC). The deadline for actual NBN proposals are postponed to an as-yet undetermined data.

3.1.4 Regulation, wholesale services

Current obligations imposed on Telstra

Currently, Telstra is obliged to offer the following wholesale services

- Unconditioned Local Loop (ULL): ULL access allows ISPs to provide their own telecommunications services over Telstra's fixed copper "last mile" network, by installing their infrastructure within local exchanges to provide typically broadband and voice services.
- Line Sharing Service (LSS): LSS allows ISPs to provide broadband services while Telstra is continuing to provide voice services simultaneously using the same copper pair.
- Duct Access: Duct Access lets operators access Telstra's network of ducts, tunnels, manholes and pits for the purpose of installing and operating their own cables and equipment.

ULL and LSS are ex ante regulated wholesale services.

Alternatives for access to the new "National Broadband Network"

The precise architecture of the new network and the resulting wholesale regime is not predetermined by the Australian Government. Rather, the Ministry for Broadband, Communications and Digital Economy announced recently: "The Government encourages interested parties to come forward with innovative proposals³⁵".

Yet, in a draft decision on the proposed FTTN network by G9 (see above) the ACCC provides guidance on access to FTTN networks more generally. Indeed, in this paper the ACCC considers that reasonable access to a new FTTN network would normally include the following:³⁶

- A bitstream access service over the last mile bottleneck, which gives the access seeker as much control as possible over its own customer traffic, so that he is able to innovate and compete,
- Access prices which reflect efficient costs (whether actual or estimated),
- Non-price terms and conditions of access that do not discriminate anti-competitively.

³⁵ See http://www.minister.dbcde.gov.au/media/media_releases/2008/023.

³⁶ See <http://www.accc.gov.au/content/index.phtml/itemId/806092>.

3.2 Japan³⁷

3.2.1 Overall broadband market penetration

Japan is the country with by far the highest FTTB/H penetration in the world; there are more than 11 mill. subscribers at the end of 2007, see Figure 7.

Figure 7: Broadband penetration in Japan according to different technologies

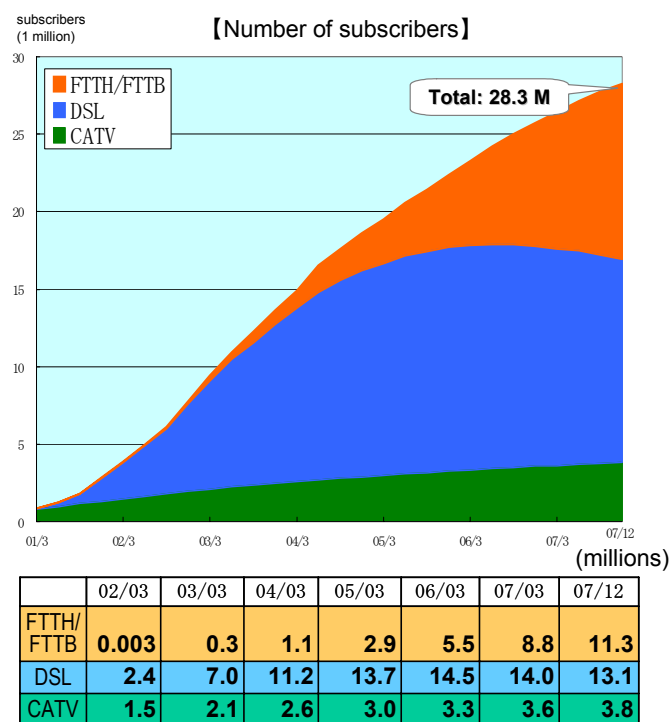

Source: Katagiri (2008)

The figure shows on the one hand that the most popular broadband service in Japan still is ADSL. On the other hand there is a remarkable shift to FTTH/FTTB over the past 3 years. ³⁸

The “Next Generation Broadband Strategy 2010” formulated in August 2006 by the Japanese Government aims at eliminating the non-broadband-areas³⁹: By Fiscal Year

³⁷ This section is based to a substantial degree on Katagiri (2008) and Taniwaki (2008).

³⁸ The number of NTT customers taking broadband services via its ADSL platform dropped from 5.3 million (as of March 31, 2007) to 4.6 million (as of March 31, 2008). The number of conventional main lines in service fell to 39.2 million from 43.3 million in this period; see TeleGeography “NTT fibre users up, ADSL subscriptions down”, May 15, 2008.

2010: (1) broadband service should be available to 100 % of the population; (2) super high speed broadband (FTTH) should be available to 90 % of the population.

3.2.2 Current broadband market structure

Several players/player groups are providing FTTx services in Japan (this does not necessarily mean that the players mentioned below actually deploy fibre)

- *Telcos*: NTT-East and –West; KDDI,
- (*Supra-*) *Regional Utilities* like e.g. K-Opticom (subsidiary of Kansai Electric Power Co.),
- CATV Provider like e.g. J:COM,
- Content Providers like e.g. useN Corp.,
- *ISPs* like e.g. Yahoo! BB,
- *Jurisdictions*: in rural and thinly populated regions.

NTT

NTT's FTTH architecture represents a typical Japanese approach: from a feeder point, the subscriber lines are deployed by aerial fibre. This is the case for 85 % of FTTH deployments in Japan, as can be seen from the next figure.

Figure 8: NTT's FTTB/H architecture

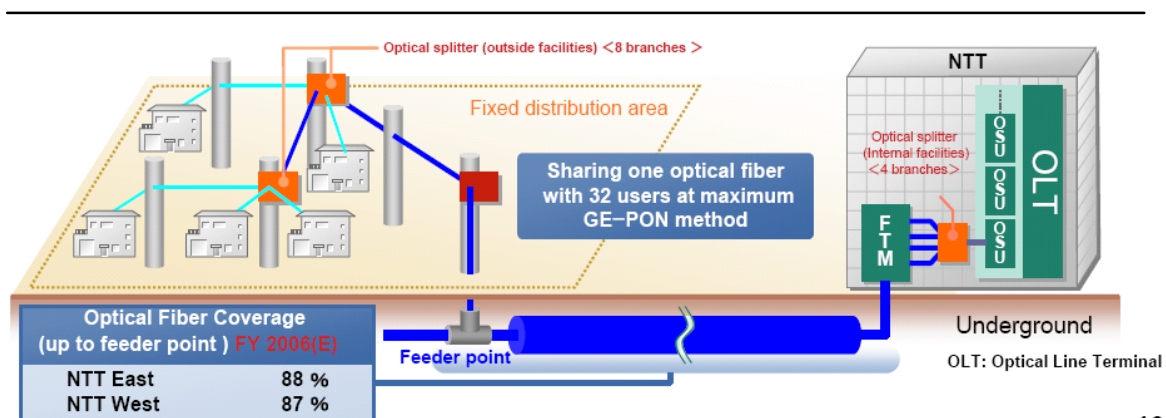

Source: NTT, Nov. 2006

Competitors, competition

We only present a few approaches.

KDDI started with infrastructure leased from *NTT* (unbundled fibre) however, over time it has re-oriented its strategy towards own infrastructure. The vehicle mainly used is acquisition and cooperation: indeed, after the acquisition of *TEPCO's* (Tokyo Electric Power) fibre optic network (October 2006) *KDDI* is now making use of this infrastructure. Moreover, *KDDI* has partnered with *East Japan Railway Company* (*JR East*) in order to use the latter's cable network (built alongside the railway tracks). However, additional investments are required to connect to nearby homes and businesses. In addition, *KDDI* has signed agreements with several cable TV operators. *KDDI's* own infrastructure is based on E-PON.

Before entering the FTTB/H market, *Usen* had been a cable broadcasting company for decades with access rights to a nationwide electric-pole network infrastructure. *Usen* became the first player in the Japanese FTTB/H market: optical fibre was added to the electricity infrastructure region by region and at the beginning was closely in tandem with *NTT*. Even today *Usen's* FTTH service is mostly provided where its own infrastructure is better developed. *Usen's* infrastructure is based on E-PON.

In Japan there is infrastructure competition at least in the big metropolises, i.e. one can observe parallel deployment of fibre strands from 4 or more operators "on the very last mile". Important drivers of this kind of infrastructure competition are the density of the population, the fact that aerial deployment of fibre on the very last mile is allowed, and regulation.

Market shares

NTT's market position with respect to fibre deployment still is very strong: as of end of March 2007, the combined market share of *NTT East* and *West* (by number of lines) regarding FTTB/H is 78.9 % (the FTTB/H share by revenue is equal to 69.0 %). With respect to the number of lines the respective market share of *NTT* in the field of copper lines is 99.9 %. With respect to revenues *NTT* accounts for a share of 90.6 % in the field of fixed telephony (including ISDN) and 38 % in the field of ADSL, see *Taniwaki* (2008).⁴⁰

⁴⁰ *NTT* reports that the number of people signed up to its FLET'S Hikari fibre-optic service reached 8.78 million as of 31 March 2008, up from 3.2 million a year earlier; see *TeleGeography* "NTT fibre users up, ADSL subscriptions down", May 15, 2008.

3.2.3 Regulation, wholesale services

General open access regime

For many years, the Japanese broadband market has been built around an open access regime. Indeed, in autumn 2000 collocation and unbundling rules for access networks of NTT East and West were established. By virtue of this decision, competitive providers were able to use essential elements of NTT's network, particularly they were entitled to obtain low cost access to copper lines to the home and to metropolitan fibre connections running between NTT exchanges and to other locations.

These elements have been the basic building blocks of competitive ADSL providers' networks in Japan, whose market impact is underlined by the following figure 7.

Figure 9: Unbundling decision and development of the DSL service market in Japan (March 99 – March 07, in million)

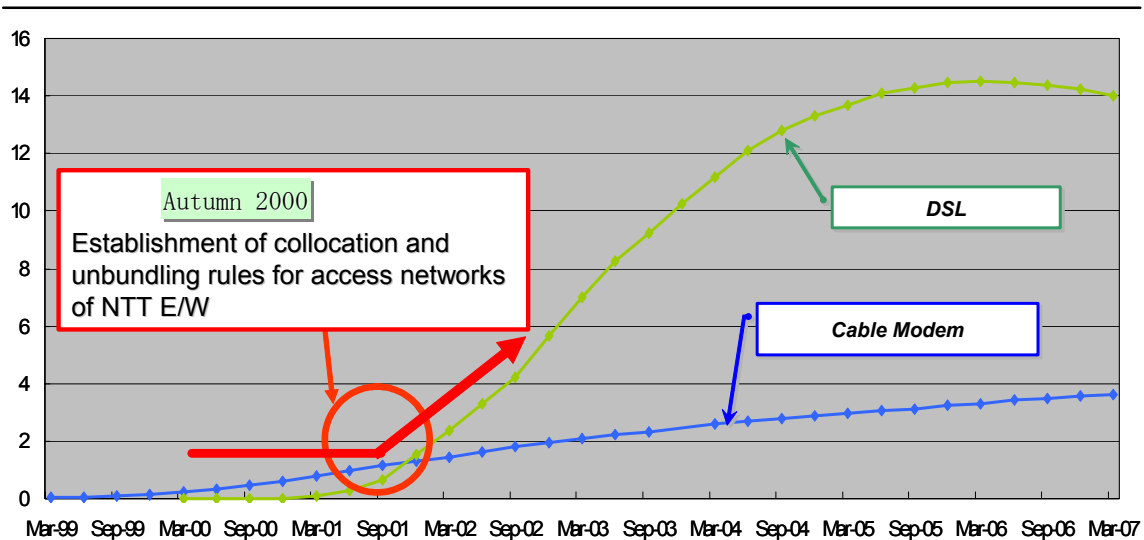

Source: Taniwaki (2008)

In more detail the following conditions applied: the subscription-based optical fibre networks owned by NTT East/West were categorized as “*category I designated telecommunications facilities*” under the Telecommunications Business Law. *Category I designated telecommunications facilities* are indispensable facilities (with a “bottleneck” function) in establishing connections with other telecommunications carriers’ facilities to achieve further user-friendliness and the development of more comprehensive and more reasonable telecommunications services. NTT East/West, who own such category I designated telecommunications facilities, are legally obliged to lay down clauses regarding connection charges and technical and connection conditions to

connection points with other carriers' telecommunications facilities, as well as to seek approval by the Minister of MIC for such clauses.

Fibre unbundling regime imposed on NTT

The following figure provides an overview of the fibre access unbundling regime regarding NTT East and West as of 2006.

Figure 10: Access charges for FTTH network elements in Japan (as of 2006; E = NTT East; W = NTT West; figures in Yen)

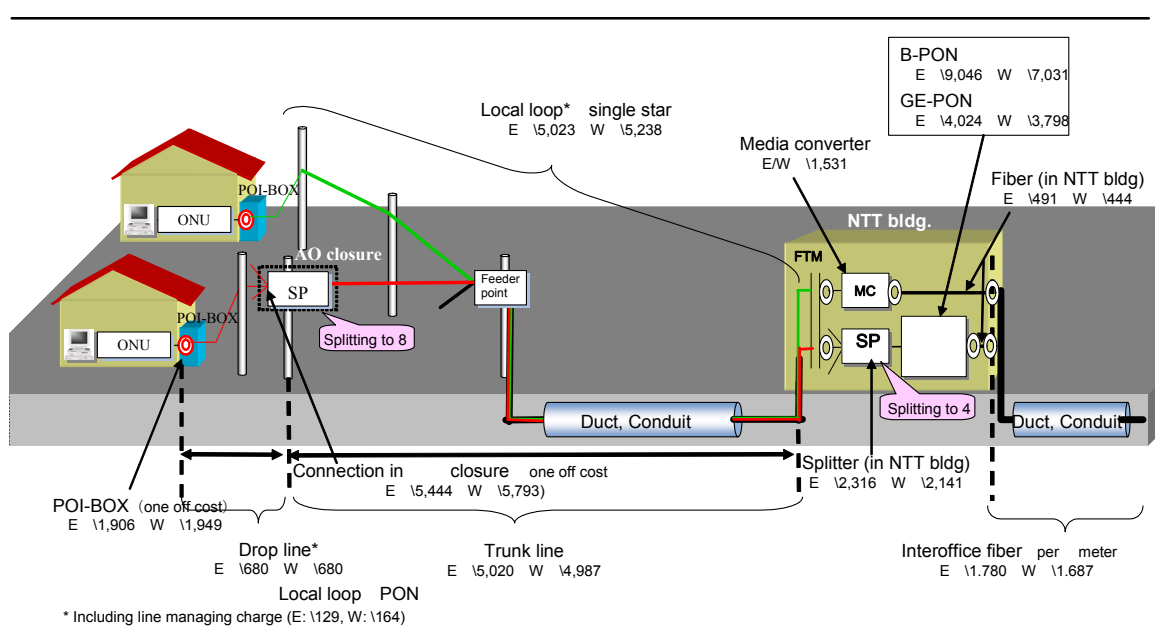

Source: Glocom (Japanese Institute of Global Communications), internal communication

The calculation of the charges for the different network elements is based on the following assumptions:

- Local loop (except for drop line): calculated by forward-looking cost method (7 years),
- OLT, Media converter, Splitter (in NTT building): calculated by forward-looking cost method (5 years),
- Others: calculated by historical cost method.

Assessment of the fibre unbundling regime imposed on NTT

We have seen above (see section 3.2.2) that NTT still is by far the largest player in the FTTB/H market with a market share of slightly below 80 %. Thus, it seems that the fibre access unbundling regime is not that advantageous to competitors.

A closer look at the price level and structure reveals the challenge that competitors are facing. For fiscal year 2007, the (local loop) fibre access charges of NTT East and West (see Figure 10, local loop single star) were calculated on the basis of the estimated actual cost of fibre deployment from 2001 to 2007. On the basis of an exchange rate of 160 Yen per Euro Katagiri (2008) reports a price of 31.7 Euros per (local loop) fibre. Katagiri points out why the price regime in all likelihood is unfavourable for competitors. The reason is that FTTB/H is usually provided by NTT via a PON architecture and in NTT's network one fibre is splitting to eight users, i.e. fibre access in Japan is giving inherently access to a group of users.⁴¹ Thus, if the competitor attracts only one out of the eight potential users the price per user is equal to 31.7 Euro, if he attracts two users the price per user is equal to about 15.90 Euro, etc., thus yielding the minimum price per user of slightly below 4 Euros if the competitor is able to attract all eight users. However, this outcome is unlikely, rather, the competitor will on average only be able to attract about two users (in reality even less, because there are potentially additional competitors) while the incumbent on average gets about six out of the eight users. Thus, the cost per user are quite different between NTT and competitors.

In October 2007 the Japanese government started to examine the system of fibre access charges for the fiscal year 2008. Three options have been discussed:

- Bitstream charge,
- Access charge per user,
- Keeping the current pricing approach.

The first two options have been rejected. The main argument against the bitstream charge was that it was considered to discourage competitors from investing in infrastructure. The issue raised in the context of the access charge per user was as follows. Some competitors such as CATV providers and subsidiaries of power companies are constructing their own access network. Does the access charge per user distort the competition between competitors? MCI therefore decided in favour of option 3, i.e. keeping the current method. However, it decided to re-calculate the fibre cost based on high-demand estimation. As a result, fibre charges will go down to 28.8 Euros/ fibre (of NTT East).

⁴¹ In our empirical model we have defined fibre local loop unbundling (fibre LLU) as one alternative of access in a fibre based environment. However, in this case our assumption is that a competitor has access to a single customer. Japan therefore is different as access to overall eight users is provided. We think the best term to describe the Japanese case is PON splitter group unbundling.

NTT East and NTT West launched full-fledged commercial services using NGNs in the second half of fiscal year 2007.⁴² The regulator (MIC) therefore has begun to study whether unbundling regulation is needed at all in October 2007. In March 2008 MIC came to the conclusion that unbundling regulation is required regarding the NGN of NTT East and West. The reasons are as follows⁴³: Currently, NTT East and West have more than a 70 % share in the FTTB/H market. Such customers are supposed to be migrated to NGN. So, the connection to NTT's NGN shall be indispensable for competitors in the future broadband market. MIC is, however, reviewing the necessity for such unbundling annually.

New Competition Promotion Programme 2010

In view of the foreseeable transition to full IP-based networks a study group was established in October 2005 to discuss how competition rules should be addressed in the shift to the IP-based network. This group presented its final report in September 2006. Based on this final report, the Japanese government launched a "New Competition Promotion Programme 2010" in October 2006. This programme is related to a comprehensive review of competition rules to address the transition to IP-based networks and aims at defining a road map to policy reform to be implemented by the early 2010s. Essentially, the programme comprises the following components⁴⁴:

- Promotion of infrastructure competition,
- Review of interconnection policy,
- Promotion of competition in the mobile market,
- Review of terminal device policy,
- Review of retail pricing policy,
- Review of the universal service system,
- Establishment of a network neutrality principle,
- Reinforcement of a dispute settlement function,
- Reinforcement of consumer protection.

Taniwaki (2008) outlines that the Japanese policy basically aims at moving from a world of "ex-ante" regulation to a world of "ex-post" regulation. This could mean in particular the abolition of Type I and Type II business categories, a drastic deregulation of price and tariff regulations and the introduction of a competition review mechanism.

⁴² See MIC Communications News Vol. 19 No.1 2008

⁴³ See Katagiri (2008)

⁴⁴ See Katagiri (2008).

In more detail, the New Competition Promotion Programme 2010 calls for⁴⁵

- Facility-based competition promoted by (1) a further opening of poles, etc. owned by NTT East and West and electric power companies, (2) the opening of fibre-optic networks installed by local governments to telecom carriers, and (3) the introduction of new wireless access technologies.
- A competition environment improved by (1) a progressive revision of dominance regulation, (2) the establishment of competition safeguards in response to NTT's mid-term management strategy, (3) the establishment of interconnection rules related to NGNs to be developed by NTT, (4) the review of the access charge calculation method for copper and optic fibre, and (5) the promotion of MVNOs into the mobile market.

Other key measures include the promotion of further competition regarding the terminal layer, the review of a Universal Service Fund mechanism, and the improvement of dispute settlement mechanisms.

The "New Competition Promotion Program 2010" will be periodically reviewed on an annual basis. In the year 2010 the Japanese government aims at making a comprehensive review regarding the status of NTT as well as passing a comprehensive legal framework including telecommunications and broadcasting.

3.3 Singapore: Next Gen NBN

Within the frame of the present study, Singapore is particularly interesting due to a sophisticated strategy to deploy fibre infrastructure, operate the network and provide services over this network. In this section we therefore focus only on analysing this issue.

Overall approach

In December 2007 the Infocomm Development Authority of Singapore (IDA) issued Requests for Proposals for the Next Generation National Broadband Network (Next Gen NBN). The approach in Singapore rests on separate entities which are responsible for specific tasks, namely ⁴⁶

- a passive infrastructure company (NetCo)
- an active infrastructure company (OpCo) that sells wholesale services to

⁴⁵ See Taniwaki (2008).

⁴⁶ The information in this section is mainly based – unless stated otherwise – on IDA (2007a) and IDA (2008).

- retail service providers (e.g. ISPs).⁴⁷

Two separate Request for Proposals have been issued for NetCo (in December 2007) and OpCo (in April 2008) each entailing 25-year licenses for the winning bid.

NetCo

The NetCo will be responsible for designing, building and operating the “passive infrastructure layer” of the Next Gen NBN. IDA specifies this passive layer to include wirelines and ducts on OSI layer 1. The NetCo entity will be subject to universal service obligations and it will be obliged to deploy fibre access ubiquitously by 2015. The government will support the deployment with a grant of up to 750 mill. S\$ (about 350 mill. Euro). The actual grant required is a decision factor for selecting the successful bidder, meaning that tenders demanding for less governmental grant will score higher. Total investment costs have been estimated at 2bn. US\$ (~1.3 bn Euro).⁴⁸

The NetCo must be *structurally separated* from other market parties. This means in particular that bidders also present in downstream markets must ensure the NetCo to be a separate entity with fully autonomous decision-making and with no effective control exercised by downstream companies on the NetCo or vice versa.

It is our understanding that the NetCo would decide on the actual design of the physical network infrastructure and provide dark fibre. The usage fees for this infrastructure will be regulated.

The Next Gen NGN must initially be capable of providing 100Mbps downstream and 50Mbps upstream bandwidth for each user.⁴⁹

The tender closed in May 2008 with submissions from two consortia (OpenNet and Infinity).⁵⁰ Interestingly the incumbent SingTel did not take the lead in the OpenNet consortium. This decision was a surprise to market experts in Singapore because SingTel currently wholly owns the major access network in the country and the OpenNet proposal underlines that OpenNet will “leverage SingTel’s existing extensive high-quality ducting network and turn it into an ultra-fast broadband network”.⁵¹

⁴⁷ From the perspective of NetCo we subsequently speak of downstream markets in the case of OpCos or retail service providers, respectively. From the perspective of OpCo we speak of downstream markets in the case of retail service providers and of upstream markets in the case of NetCo.

⁴⁸ Source: Heavy Reading. http://www.lightreading.com/document.asp?doc_id=141145&print=true

⁴⁹ Eventually it shall be able to provide speeds of 1Gbps and beyond per end-user. Source: IDA (2007b), p.19.

⁵⁰ See Table 1 in Annex 1 of the present report for the members of the two consortia.

⁵¹ See Communications Day, May 6, 2008; issue 3266.

OpCo

The OpCo is responsible for the design, build and operation of the active infrastructure layer of the Next Gen NGN. IDA specifies this active layer to include switches and routers on OSI-layers 2 and 3. OpCo shall provide services to 330k residential and 80k non-residential customers by 2015. The government will support OpCo with a grant of up to 250 mill. S\$ (about 117 mill. Euro). Again, bidders score higher the less they require governmental grants.

OpCo will provide wholesale services at regulated prices to the retail service providers. Public information is not entirely clear as to whether there will be just one or multiple OpCos. We would anticipate to see only a single OpCo. OpCo is also subject to a universal service obligation.

OpCo must be *operationally separated* from downstream parties. This is a less stringent separation than that of NetCo and allows OpCo to retain shares of downstream companies (i.e. retail services providers like ISPs).

However, OpCo is obliged to be established as a separate legal entity. It must provide equivalence of inputs to all downstream operators (same prices and terms, same processes and information). Furthermore, OpCo must be independent from affiliated downstream operators, which means OpCo must

- operate in all respects on a stand-alone basis,
- be located in separate premises,
- independently formulate and make its own decisions on its assets and commercial policy,
- deny its board of directors, management and employees to take responsibilities in any affiliated operator or enjoy incentive schemes affiliated with the performance of affiliated operators,
- ensure compliance with these requirements through maintenance of governance manual, compliance to performance indicators and reporting to a monitoring board.

11 companies are known to have been pre-qualified by IDA for the OpCo tender which will close in August 2008.⁵² Among them are

- the two consortium leaders of the NetCo tender (City Telecom (H.K.) Limited; Axia NetMedia Corporation),

⁵² See Table 2 in Annex 1 of the present report.

- carriers, i.e. BT Singapore Pte Ltd, Deutsche Telekom Asia Pte Ltd, MobileOne Ltd. (competitor in Singapore, member of NetCo Infinity Consortium), Nippon Telegraph and Telephone West Corp., Singapore Telecommunications Ltd., StarHub Ltd. (competitor in Singapore, member of NetCo Infinity Consortium),
- manufacturers like Alcatel-Lucent Singapore Pte Ltd. and Nokia Siemens Networks Singapore Pte Ltd. and
- Singapore Computer Systems Ltd.

Retail service providers

Retail service providers purchase bandwidth connectivity from OpCo and compete with each other in providing services to end-users.

Selection criteria

Selection criteria for the NetCo are attractiveness of business plans to industry⁵³ (43 %), quality of network infrastructure (25 %), level of government grant (22 %) and financial proposition and strength of the bidder (10 %).

OpCo selection criteria are attractiveness of wholesale price (45 %), attractiveness on non-price related wholesale terms (25%), quality of network infrastructure (15 %) and level of government grant (15 %).

53 This primarily includes wholesale prices and “attractiveness of the interconnection offer”. The latter consists of “basic product offering and terms&conditions” and “adaptability of service offerings”. It appears questionable how the NetCo – virtually being just a dark fibre provider – could adapt its service offerings. Details regarding the elements of the Interconnection Offer of the NetCo are not publicly available. We expect that these are related to physical aspects of interconnection, i.e. co-location sites and available ducts/fibres and/or the fibre architecture chosen.

Wrap up

The following figure visualizes the envisaged three level industry infrastructure in Singapore.

Figure 11: 3-level industry structure envisaged in Singapore

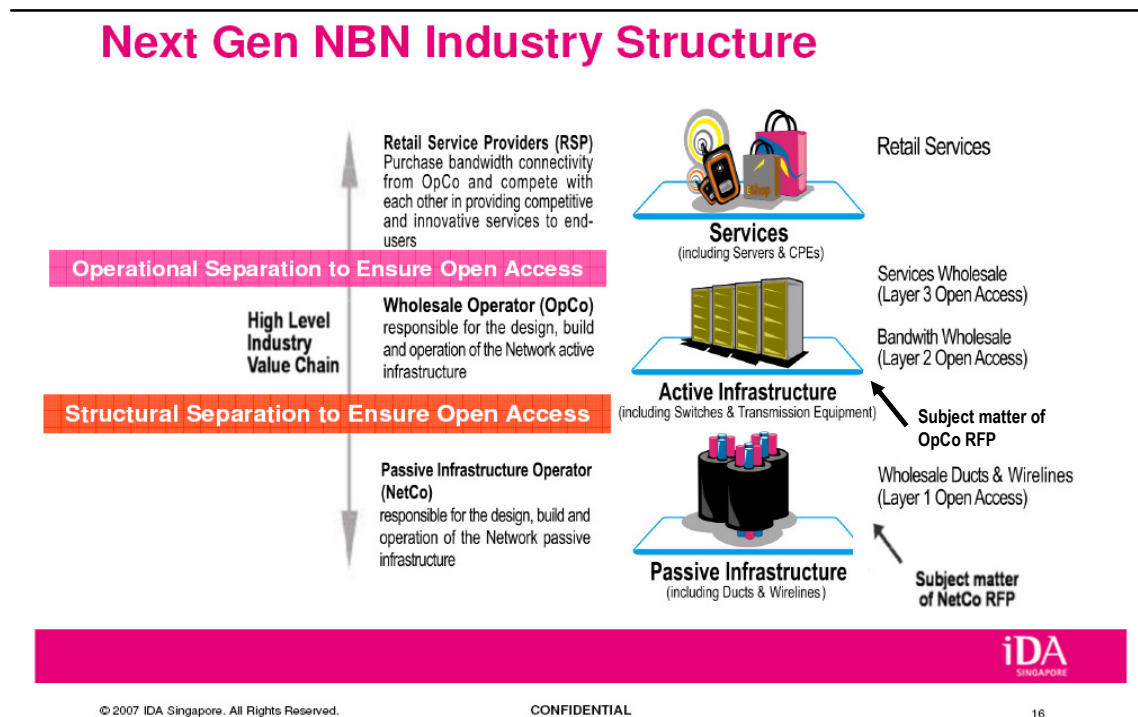

Source: iDA Singapore (2007) / WIK-Consult

The double layer of separation between retail and wholesale is a very strong form of separation and probably the strongest example in international comparisons.

The logic of the Next Gen NGN structure has been criticised both regarding incentives of the involved players and efficiency of interoperation. For example, the question is raised how network planning, customer provisioning and fault handling can be efficiently and adequately realised considering structural separation between the two players and the potential for friction resulting from this separation. ⁵⁴

⁵⁴ Indeed, Chan and Lynch (2008) argue: “Although the NetCo and OpCo would be required to be structurally separate, in reality they would need to work closely to ensure smooth provisioning of the network to individual customers. This might work well in the case of the north European NetCo/OpCo arrangements (apparently Singapore has been inspired to do this by a Stockholm municipal example) but those networks would appear not to be subject to the performance targets of Singapore (100Mbps initially, rising to 1Gbps). These requirements and “management” asymmetries create heavy “optimisation” incentives to pass the buck on deployment topology, costs and perhaps even service provision between the two entities.”

3.4 USA

3.4.1 Overall broadband market penetration

The United States has the greatest total number of broadband lines of all OECD countries. However, on a population adjusted basis, the U.S. ranks just 15 out of the 30 OECD member countries surveyed.⁵⁵ The OECD defines broadband connections as those offering Internet connectivity which are capable of download speeds of at least 256 Kbps. As of December 2007, the OECD reports that the US had slightly more than 69.8 million such lines.

According to the most recent statistics from the Federal Communications Commission, there were 100.9 million “high-speed” lines in service, see figure Figure 12.⁵⁶ This represents a more than 20 fold increase over 2000.

Figure 12: Total High-Speed lines in the USA

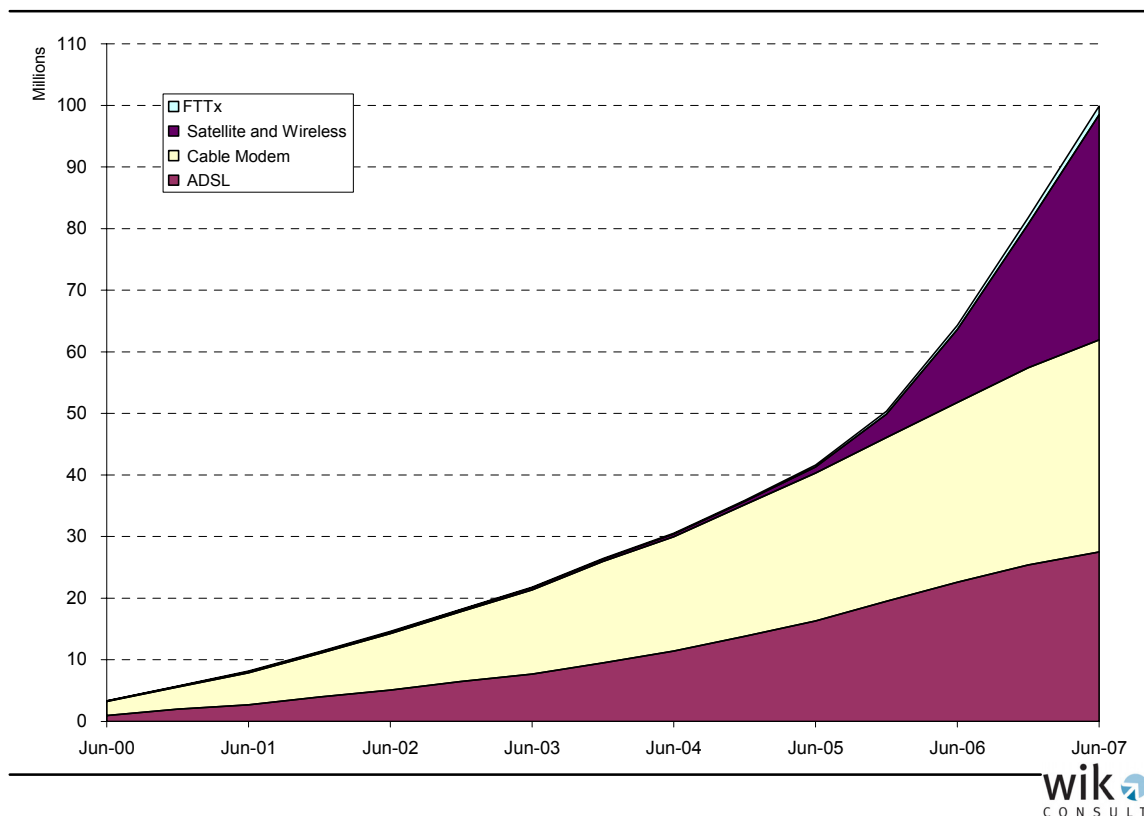

Source: FCC

⁵⁵ http://www.oecd.org/document/54/0,3343,en_2649_33703_38690102_1_1_1_1,00.html

⁵⁶ http://hraunfoss.fcc.gov/edocs_public/attachmatch/DOC-280906A1.pdf

However, it is worth noting that the FCC defines high-speed lines as being faster than 200 kbps in one direction. The meaning of the term 'high-speed lines' is for all intents and purposes equivalent to the term 'broadband'. FCC staff routinely use the two interchangeably.

The FCC introduced the current definition of high speed in its 1999 first report assessing the state of advanced services.⁵⁷ A year later the FCC released its second report on availability of high speed services. In the second report, the FCC began to collect data using the US system of postal ("zip") codes, by requiring network operators to report a list of the zip codes where they had at least one customer of high-speed service.⁵⁸ Eight years later, the FCC made significant changes to the way it collects and reports the data concerning broadband in the United States.⁵⁹ In June 2008, the FCC has published a Report and Order that requires network operators to report high speed lines based on census tract, not zip codes. Further, network operators are required to report high speed lines according to a variety of speeds: 200 Kbps to 768 Kbps; 768 Kbps to 1.5 Mbps; 1.5 Mbps to 3 Mbps; and above. Although the new approach offers data with greater granularity, the FCC continues to define high speed lines using the 200 Kbps standard.

⁵⁷ Federal Communications Commission, Report, *In the Matter of Inquiry Concerning the Deployment of Advanced Telecommunications Capability to All Americans in a Reasonable and Timely Fashion, and Possible Steps to Accelerate Such Deployment Pursuant to Section 706 of the Telecommunications Act of 1996*, CC Docket No. 98-146 (2 February 1999).

⁵⁸ Federal Communications Commission, Second Report, *In the Matter of Inquiry Concerning the Deployment of Advanced Telecommunications Capability to All Americans in a Reasonable and Timely Fashion, and Possible Steps to Accelerate Such Deployment Pursuant to Section 706 of the Telecommunications Act of 1996*, CC Docket No. 98-146 (21 August 2000).

⁵⁹ Federal Communications Commission, Report And Order and Further Notice of Proposed Rulemaking, *In the Matter of Development of Nationwide Broadband Data to Evaluate Reasonable and Timely Deployment of Advanced Services to All Americans, Improvement of Wireless Broadband Subscriberhip Data, and Development of Data on Interconnected Voice over Internet Protocol (VoIP) Subscriberhip*, WC Docket No. 07-38 (12 June 2008).

3.4.2 Current broadband market structure

Several player groups are actively involved in the deployment of fibre infrastructure in the USA, see figure Figure 13.

Figure 13: FTTx player groups in the USA⁶⁰

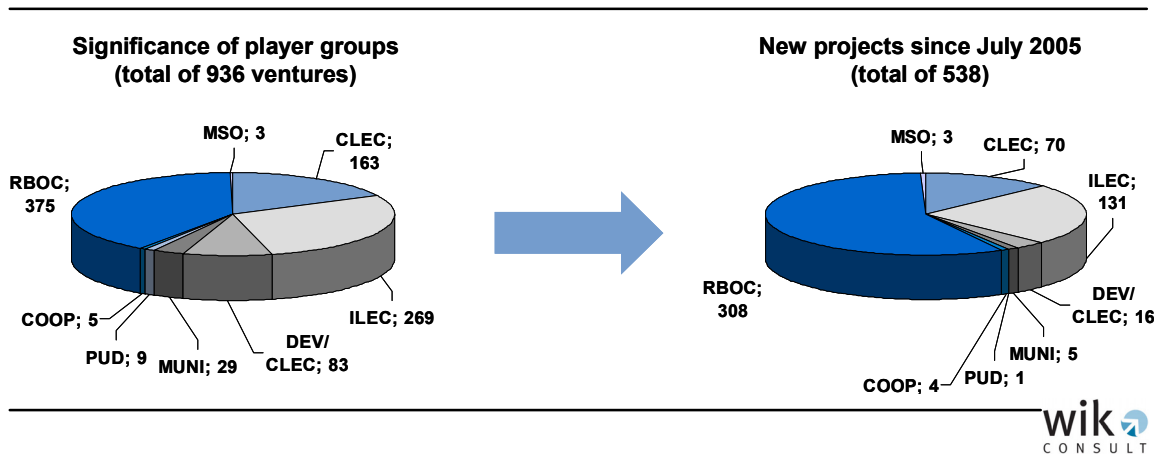

The figure shows that FTTH projects witnessed remarkable growth since 2005. RBOCs account for nearly 60 % of the new projects initiated in 2005 – 2006; the CLECs share in new projects is 13 % and the ILECs share in new projects is 24 %. In view of the relatively low number of new projects it is fair to state that all other player groups have a reduced (relative) market position.

Regarding technology, nearly all market participants, including the RBOCs, have been choosing deployment of PON fibre architecture, especially G-PON, see below. Figure 14 shows the architectures of non-RBOCs' deployments.

⁶⁰ In this figure the acronyms have the following meaning: CLEC stands for Competitive Local Exchange Carrier; ILEC stands for Incumbent Local Exchange Carrier (the non-RBOC incumbents); MUNI stands for municipalities; COOP stands for cooperatives; RBOCs stands for Regional Bell Operating Companies; PUD stands for Public Utility District, MSO stands for Multiple System Operator.

Figure 14: Architectures of non-RBOCs' deployments in the USA

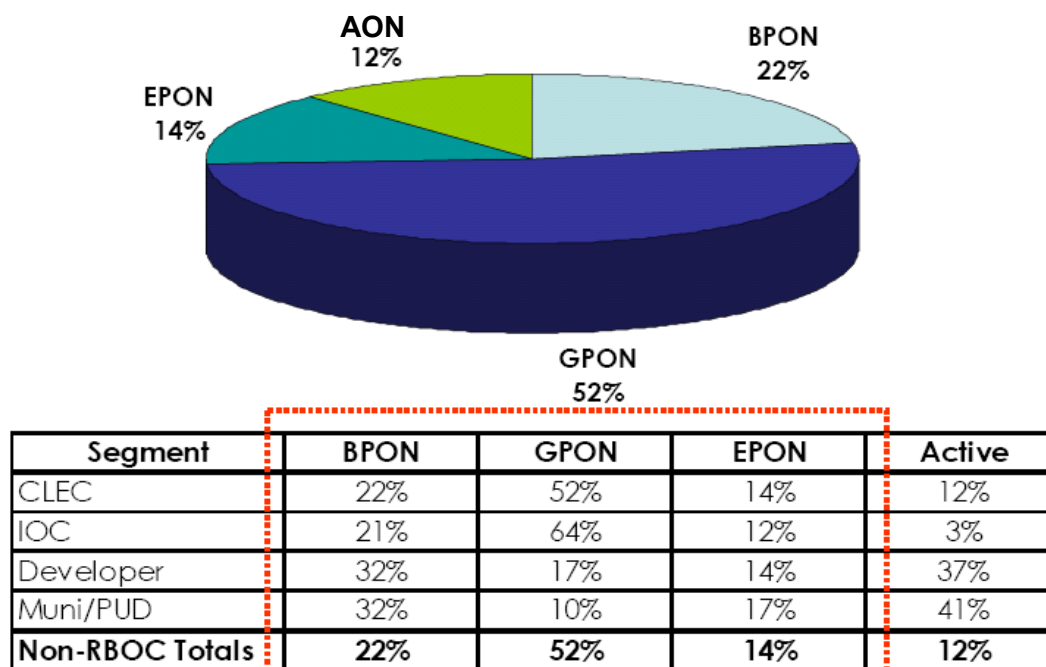

Source: Broadband Trends.com, Feb. 2007

Verizon

Verizon is mainly focusing on an FTTP approach, where the Optical Network Unit is placed at or inside the building, see Figure 15.

Figure 15: Verizon strategy to transform the home network

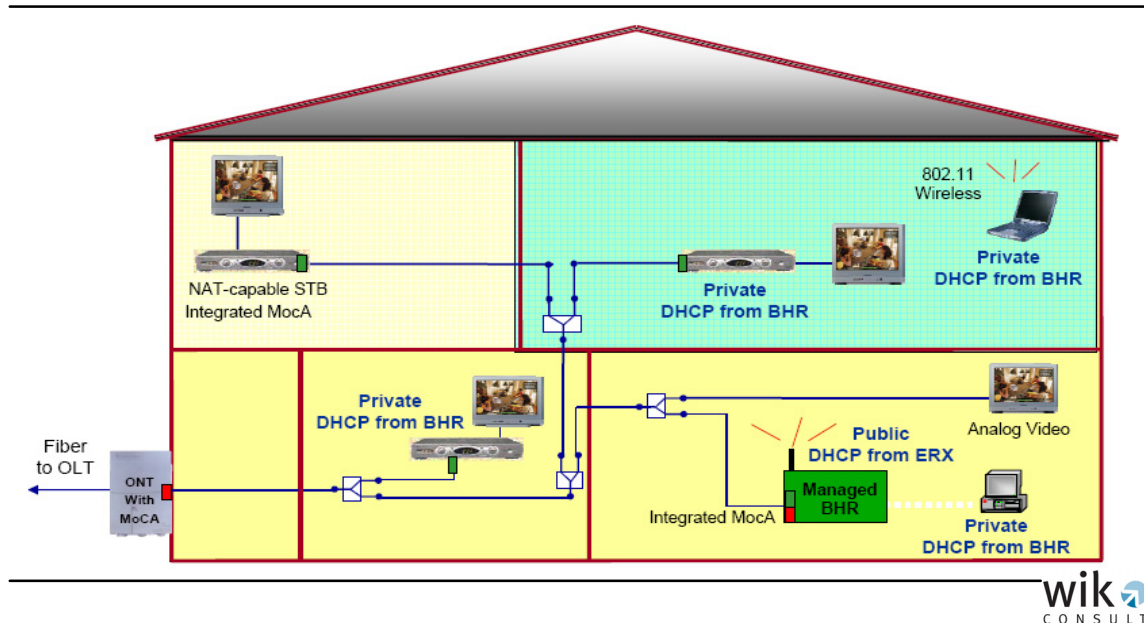

Source: Verizon

Verizon's strategy rests on a \$23 billion investment in the deployment of PON technologies through 2010. "FiOS is a passive optical network (PON) that uses a passive optical splitter to distribute data from the nearby optical line terminal (OLT) to up to 32 residential and small business premises."⁶¹ Currently, they install G-PON technology, which is capable of delivering 2.4Gbps downstream / 1.2Gbps upstream. However, plans are being developed to install WDM-PON technologies in about 3 – 5 years. Verizon presently has over one million current subscribers to its FiOS FTTH TV offering, with over 9.3 million premises passed with FTTH in the U.S.

AT&T

AT&T (the new company comprising the two "old" RBOCs SBC and Bell South as well as the "old" AT&T) mainly focus on FTTC/FTTN. This approach is pursued in overbuild situations. FTTP is used only in greenfield cases. The fibre in AT&T's U-verse network is deployed to nodes which are on average 3,000 feet (900 meters) from the house. Copper loop lengths are at maximum of 5,000 feet (1,500 meters).

Regional/local ventures

As outlined above there are a multitude of regional and local ventures focusing on the deployment of fibre.

⁶¹ http://archive.evaluationengineering.com/archive/articles/0905/0905ethernet_now.asp

One example is UTOPIA (stands for Utah Telecommunication Open Infrastructure Agency). Utopia is a governmental agency formed by 14 Utah urban and rural municipalities (450,000 population), tasked with building a community owned Metronet for 170,000 potential subscribers. The plan is to provide lit fibre to qualified resellers who provision full services.

Another example is Jackson Energy Authority (JEA), a public utility service in Tennessee. JEA's activities are concentrating on AON because of "its ability to scale". 650 miles of plant are planned, 550 aerial and 100 underground, to pass 26,000 residential and 5,000 commercial/industrial users. The business model rests on the provision of triple play services. Analog, digital, HDTV video services will be provided directly by JEA. Voice and data services, will be provided by CLECs and ISPs who pay access fees for last mile transport, as well as for marketing/customer support.

A 2004 Supreme Court ruling held that federal law does not prevent States from adopting legislation which would prohibit municipalities from offering telecommunications services.⁶² To date, some 20 States have considered or enacted legislation which prohibits or restricts the ability of municipal organizations to publicly offer communications services. Yet, it is also fair to state that municipal projects, representing one of the strongest early entrants, face resistance from incumbents through the courts and state legislatures.

Cable companies

The cable television companies Comcast and Time Warner are the second and fourth largest ISP in the US, respectively. Both companies employ HFC networks employing DOCSIS (Data Over Cable Service Interface Specification). Comcast has recently upgraded to DOCSIS 3.0.

3.4.3 Regulation, wholesale services

In its Aug. 21st, 2003, triennial review order, the Federal Communications Commission (In the Matter of Reviewing of Section 251 Unbundling Obligation of Incumbent Local Exchange Carriers) abolished to a large degree the unbundling obligations for ILECs' FTTH loops (whether dark or lit). This abolition is valid for new FTTH deployment which previously has not been served by any loop facility and for FTTH overbuilds, parallel to or in replacement of the existing copper loop. In the latter case, however, there are two additional specifications: the existing copper loop connection has to be maintained and non-discriminatory access to that copper loop on an unbundled basis has to be provided or non-discriminatory access to a 64 kbps transmission path (capable of voice

⁶² See *Nixon v. Missouri Municipal League*, 541 U.S. 125 (2004).

grade service) over FTTH loop on an unbundled basis has to be provided if the copper loop is completely retired.⁶³

Later on, the requirement for shared access for DSL was removed. Local loops are still available from the incumbents on an unbundled basis; however, in order to get the loop from the incumbent, the entrant needs to be collocated in the incumbent's central office and the loop has to be connected to the entrant's network equipment. According to the most recent FCC statistics in 2006, approximately 7.2% of the 146 million lines in the U.S. were provided using unbundled loops.⁶⁴ By comparison, only 3.1% of xDSL connections were provided by non-incumbents, see below.⁶⁵ One plausible explanation for the disparity between the competitive penetration in telephony and broadband is the cost of collocating the DSLAM equipment necessary to offer xDSL.

However, a second reason might be related to the market presence of broadband access providers via cable in the U.S.. Indeed, cable enjoys a higher market share of residential broadband lines (about 50.6% cable share compared to a 39.4% DSL share)⁶⁶ and therefore there might be a distorting effect on the number of competitors who make use of unbundled loops to provide broadband.

3.4.4 Wrap-up

The US high speed broadband and triple play market is characterised by a high degree of intermodal competition, comprised in large part between cable companies and the three remaining RBOCs. These market players, competitive network operators and others have in turn followed fibre based deployment strategies in separate regional areas with different architectural approaches.

Due to characteristics of US telecoms law, decisions concerning withdrawal of regulation, including traditional obligations of non-discrimination appear to have been based on classifications of services, rather than an assessment of the implications of possible market power.

Since the withdrawal of unbundling regulation, the U.S. wholesale broadband Internet access market has declined. Indeed, as Figure 16 shows, in mid 2003 more than 5 % of all DSL lines in the U.S. were provided by competitors. However, as of December 2006 this market share has declined to a level of 3.1 %.

⁶³ Assessments of the unbundling policy in the U.S. are e.g. provided by Bauer (2005) and Vogelsang (2005).

⁶⁴ http://hraunfoss.fcc.gov/edocs_public/attachmatch/DOC-284932A1.pdf

⁶⁵ http://hraunfoss.fcc.gov/edocs_public/attachmatch/DOC-280906A1.pdf

⁶⁶ Federal Communications Commission, Industry Analysis and Technology Division, Wireline Competition Bureau, *High-Speed Services for Internet Access: Status as of June 30, 2007* (March 2008), available at http://hraunfoss.fcc.gov/edocs_public/attachmatch/DOC-280906A1.pdf

Figure 16: Development of high speed DSL lines 2000 – 2005 and market share of CLECs in the USA

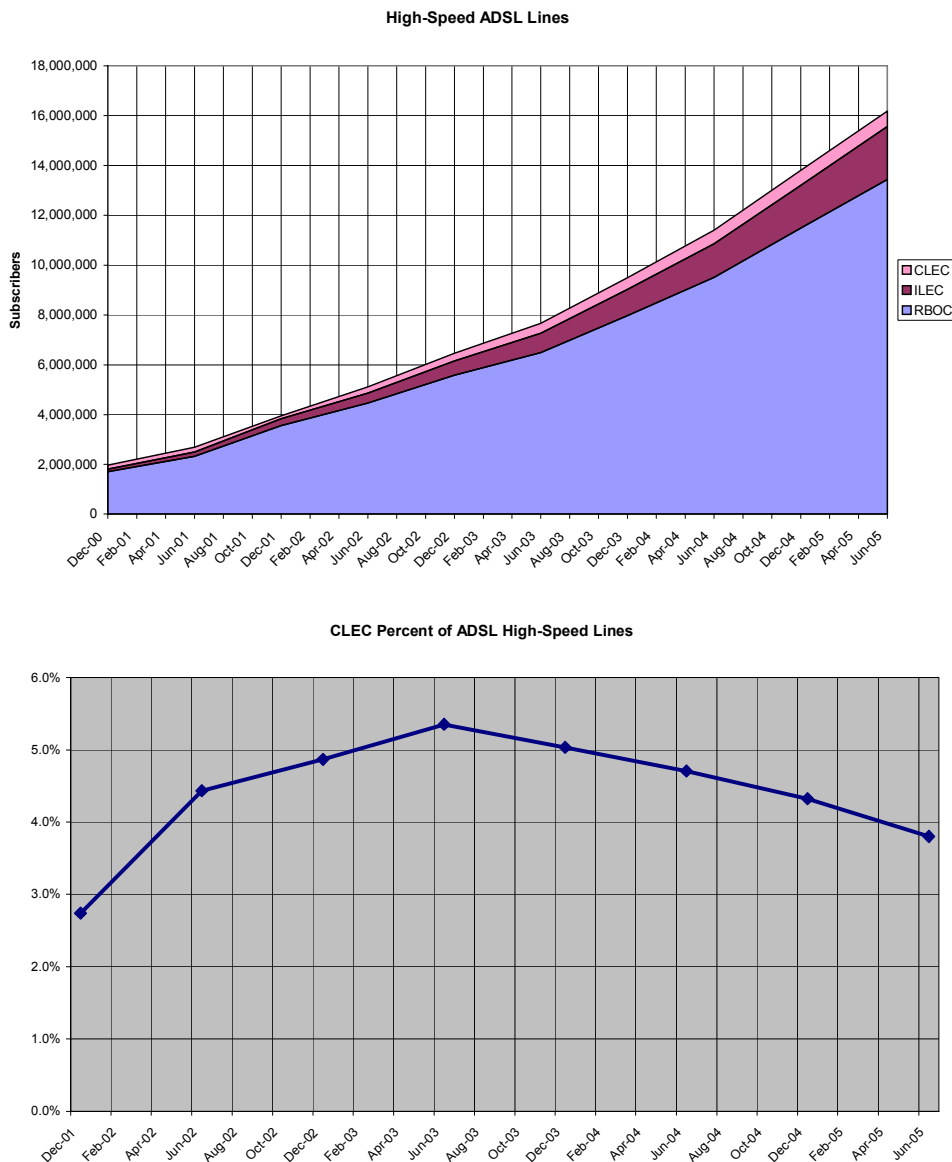

Source: FCC reports based on Form 477 carrier data

Consolidation amongst local access carriers and between local access and long distance carriers has also accelerated with mergers in 2006/07 between SBC/AT&T, Verizon/MCI, AT&T/Bellsouth.

4 Generic business model for NGA

One of the main tasks of this study is the development of a generic business model. This model shall allow on the one hand the assessment of the viability of next generation access business models. On the other hand regulatory recommendations should be derived that allow a maximum degree of viable duplication (replicability) whilst ensuring competition in the provision of services to consumers and businesses.

Thus, the main questions to answer are:

- Under which circumstances is a NGA business model viable or starts to become profitable?
- Under which (additional) circumstances is it replicable? Thereby, the conditions for replicability focus on the identification of conditions that need to be fulfilled so that a second mover could enter the NGA business in a viable manner.

The profitability in the network access business strongly depends on the market share reached and on the penetration rate of homes connected to the network. We therefore have decided to model the critical market share at which the NGA business would reach viability. In order to calculate the critical market share we make a steady state assumption, taking a time in the future where the NGA business already is developed and ignore any ramp up cost. We use the market share achieved in the relevant market as input parameter. We then compare the cost to roll out a NGA network to an area with 100% homes connected with the revenues achieved by the customers connected, i.e. with the revenue determined by the input parameter. The market share is increased from zero to that value where the revenue per user is equal to the cost per user. This is the critical market share where the NGA business starts to become viable, dependent on the market share (for more details see section 4.2).

From the previous studies described in Chapter 2 it is known that the viability of access networks strongly depends on the subscriber density (subscriber per km²) and on settlement structures. The denser the subscribers, the sooner the access network will become viable.

The model therefore is based on a set of clusters each characterized by specific subscriber densities (see Table 6). The viability of a specific business model is calculated for each cluster separately, like for a separate profit center, i.e. the viability of a business model in cluster A is independent from the viability in cluster B. In each of the clusters we assume the access network to be rolled out to 100% homes connected. For each of the clusters, the point where the NGA business may become viable is calculated individually and independently from the results of other clusters. Yet, all clusters rely on the same model assumptions.

The model starts its computation for the different clusters in the order of decreasing subscriber density. Thus, the critical market share needed for the viability of a NGA business model is calculated for the dense urban cluster first and for the rural cluster at last.

A priori the critical market share for a less dense cluster (e.g. suburban) may be higher than the one for a denser cluster (e.g. urban). The results for the clusters are independent from each other inasmuch as there is no subsidy between the clusters. As the model treats the clusters as “profit centres” it allows a possible investor for a NGA business to decide in which clusters to invest irrespective of the result of other clusters.

Table 6: Model specification: Clusters of subscriber densities

Geotype		Cluster	Subscriber density per km ²
Urban	(1)	Dense Urban	> 10.000
	(2)	Urban	> 6.000
	(3)	Less Urban	> 2.000
Suburban	(4)	Dense Urban	> 1.500
	(5)	Suburban	> 1.000
	(6)	Less Suburban	> 500
Rural	(7)	Dense Rural	> 100
	(8)	Rural	≤ 100

Source: WIK-C

In the model we compare the revenue side of the NGA business with the cost side. The revenue side typically is described by the average revenue per user (ARPU), which is a proxy for the price the customers pay for the services. The cost side has to take account of the whole network “value chain”, i.e. from access to backbone network.

The rest of this chapter is organized in four sections. Section 4.1 describes the basic technical network characteristics of a FTTC-VDSL approach, of a FTTB/H PON approach and of a FTTB/H point-to-point approach. Moreover, we focus on specific input services that might be regulated, and which are taken account of in the model. Section 4.2 focuses on the characterization of the overall model approach. Section 4.3 is devoted to the main input variables of the model. Section 4.4 finally concentrates on the model output, i.e. it explains the typical model results.

4.1 Basic technical network characteristics

The basic network infrastructure considered in the model is illustrated in Figure 17. Thus, the network consists of:

- the IP core network,
- the concentration network and
- a subscriber access network.

The core network provides nationwide physical coverage with network infrastructure, the interconnection to other networks and the central services and applications. It comprises routers (Label Switch and Label Edge Routers (LSR/ LER)) being connected in a redundant way, servers hosting and providing services (caches, B-RAS, softswitches, ...) and gateways to other networks. We assume the provision of triple play services (IP-TV) in our model. Due to the broadcast/ multicast type of TV signal distribution we assume the central points of TV signal supply to be located in the core network as well. A backbone network for a country like Germany e.g. typically has 50 network locations.

Figure 17: NGN/ NGA network architecture: Illustration

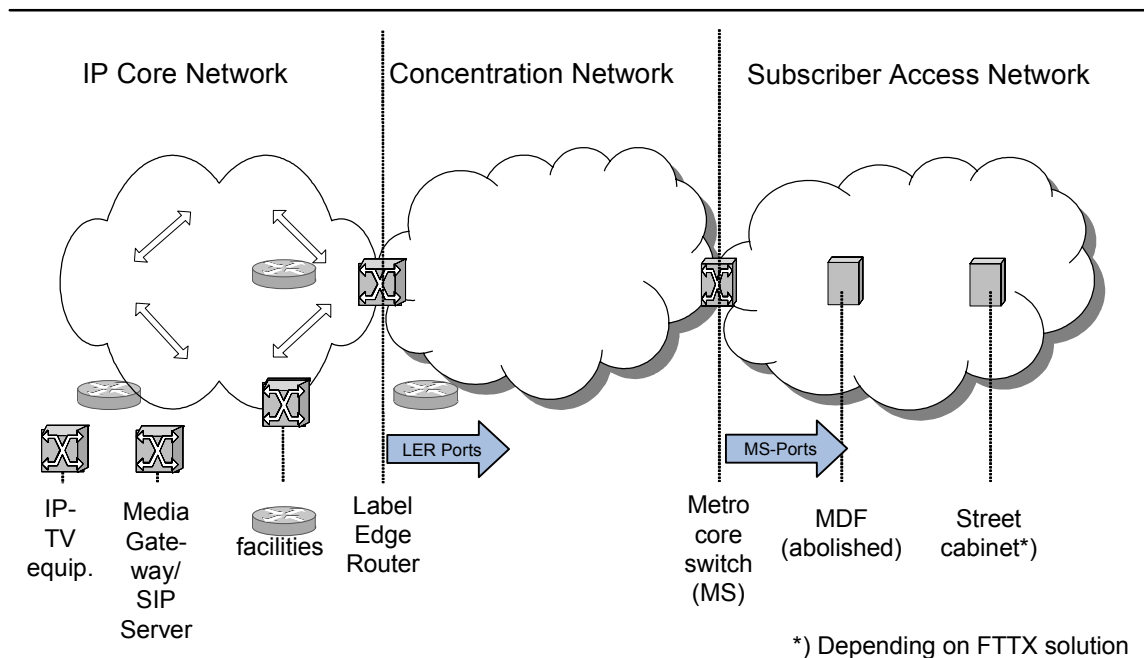

Source: WIK-C

The concentration network transfers and concentrates the traffic from metro core locations to the backbone nodes, using Ethernet switches. We assume the metro core

locations to be located at MDF (Main Distribution Frames) sites or local exchanges of today's copper access network. Since NGA networks replace or overbuild copper lines by fibre, the new architecture can overcome the line length restrictions of copper lines. Fibre lines allow lengths above 20 km distance between the fibre endpoints, while the copper network was designed to less than 4 km on average. While copper lines allow over this distance transmission rates up to roughly 2 Mbit/s with SHDSL or ADSL2+ (decreasing with increasing line length), fibre has no effective limitation.

Thus, with fibre as transmission medium in NGA architectures it is possible to reduce the amount of cable concentration locations, which had been the MDF locations for the copper network. We therefore assume the number of new metro core locations to be (far) less than the number of MDF locations, concentrating up to approximately 40.000 subscribers each. This characteristic value for an MCL site can be varied in the model. It has been set according to practical experience with larger cable concentration locations and due to the fact that larger copper MDFs reach comparable sizes.

Both the IP core and the concentration network are not modelled in detail across all network elements, but by the cost per 10 kbit/s network traffic load in the busy hour per customer⁶⁷. The costs are then calculated by the average traffic per customer in a customer mix we describe together with the ARPU assumptions and being summed up.

The metro core location is the border between the Concentrator and the Subscriber Access Network. In the metro core locations the customer traffic is fed into Ethernet switches which then concentrate the traffic to the backbone nodes. There exist various different architectural approaches for the subscriber access network. In this study we consider Fiber-to-the-Curb (FTTC) VDSL (Very High Speed Digital Subscriber Line), Fibre-to-the-Home (FTTH) PON (Passive Optical Network) and FTTH P2P (Point-to-Point) Access Networks (Figure 17). With FTTC networks the fibre ends in the street cabinets (SC) or in buildings near the customer premises and the communication is then transferred over the existing copper access lines. With FTTH a fibre always ends in the customer home (apartment, dwelling). A further variant is FTTB (Fibre-to-the-Building). It can be described in a simplified way as FTTH, while the fibre ends in the basement of the buildings and the communication path to the end users will be continued using existing inhouse cables. This might limit the bandwidth to the end customer in the case of copper inhouse cable. Therefore this variant is not considered in this study. We would expect results for it to be slightly cheaper than the FTTH solutions, but more expensive than VDSL and less viable than Loop Unbundling solutions. Thus the results will be within those being spanned out by the solutions chosen.

⁶⁷ The price per 10 kbit/s has been taken from external models and has been adjusted due to the experience of ECTA members. Thus modelling could concentrate on the NGA part.

Figure 18: Different technical solutions for deep fibre deployment in the local loop: Illustration

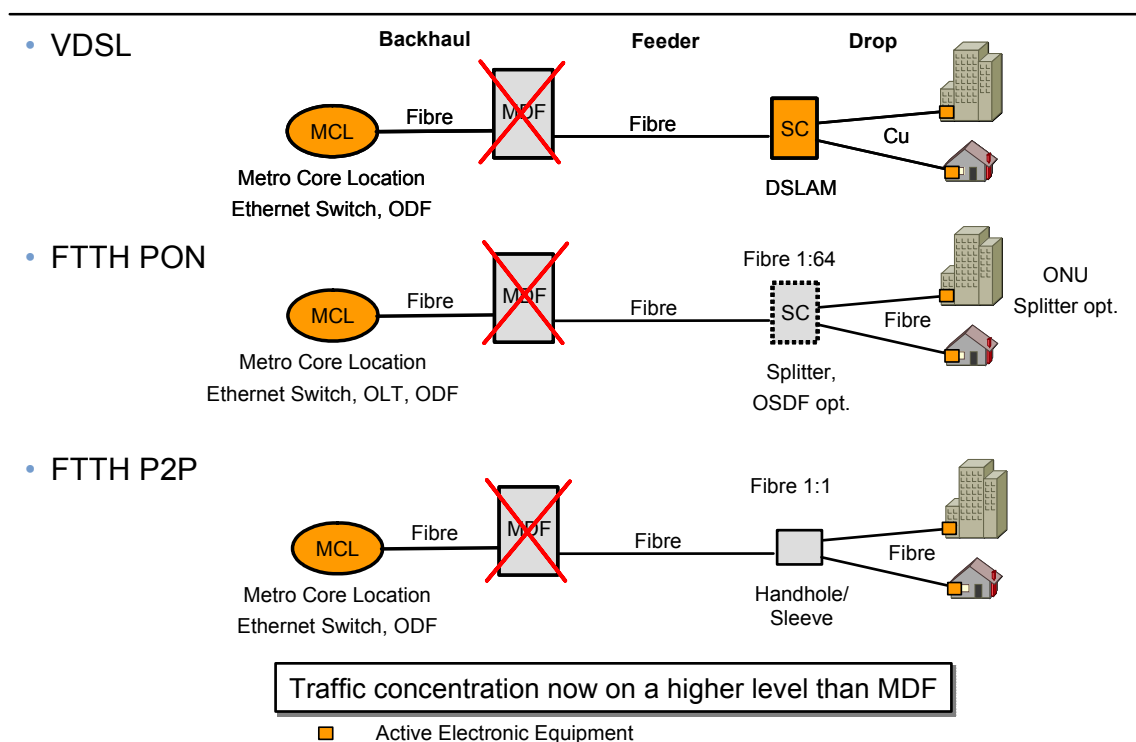

Source: WIK-C

The model is programmed in such a manner that one of the aforementioned access architectures has to be chosen as the first input parameter.

The model is constructed as bottom-up LRIC, i.e. it calculates the costs of the investment needed for a certain degree of coverage and market share, considering all cost elements needed to produce the service. This will be described in the following sections in more detail.

4.1.1 The FTTC-VDSL model

With FTTC-VDSL the copper access lines, which today end in the MDF locations, will be shortened and then end at the street cabinet. Over these shorter copper sub-loops, a VDSL broadband signal can be transmitted⁶⁸. The street cabinets have to be exchanged in order to be able to install DSLAMs, which terminate the electrical copper

⁶⁸ The available bit rates of VDSL are very much dependent on the length of the copper line, see Wulf (2007) or Williamson et al. (2008). The advantages of VDSL regarding bandwidth over ADSL disappear at sub-loop distances of more than 500 m.

signal and concentrate it in an Ethernet protocol over fibre up to the metro core location. Ethernet switches in the metro core location further concentrate the traffic through the concentration network to the IP core network. Since the distance between the DSLAM in the street cabinet and the Ethernet switch in the metro core location is not limited by copper transmission characteristics it may be larger than before.

Many of the MDFs may be closed down, or remain as a mere infrastructure node point because of the existing duct infrastructure, and be replaced by a metro core location. We assume up to approximately 40.000 end customers to be concentrated in one future metro core location.⁶⁹

In many cases street cabinets are cascaded as shown in Figure 19. Normally all SCs are connected with a fibre feeder cable in order to connect the DSLAM. But one might save DSLAMs and the replacement of the street cabinet if the sub-loop length between the street cabinets of a higher order and the end customers do not exceed about 500 m. In this case, some street cabinets of lower order may be closed down or just be kept as copper distribution frames and need not be replaced. The customers will then be connected by copper sub-loops passing through the SC of lower order to the DSLAM in the SC of higher order. In order to consider this optimization the model allows to use a reduction factor for the amount of street cabinets to be replaced and upgraded.

⁶⁹ Actual planning of competitive operators consider as well metro core locations with customer concentrations of only about 10.000 customers.

Figure 19: Use of existing (unbundled) sub-loops in an FTTC-VDSL environment: illustration

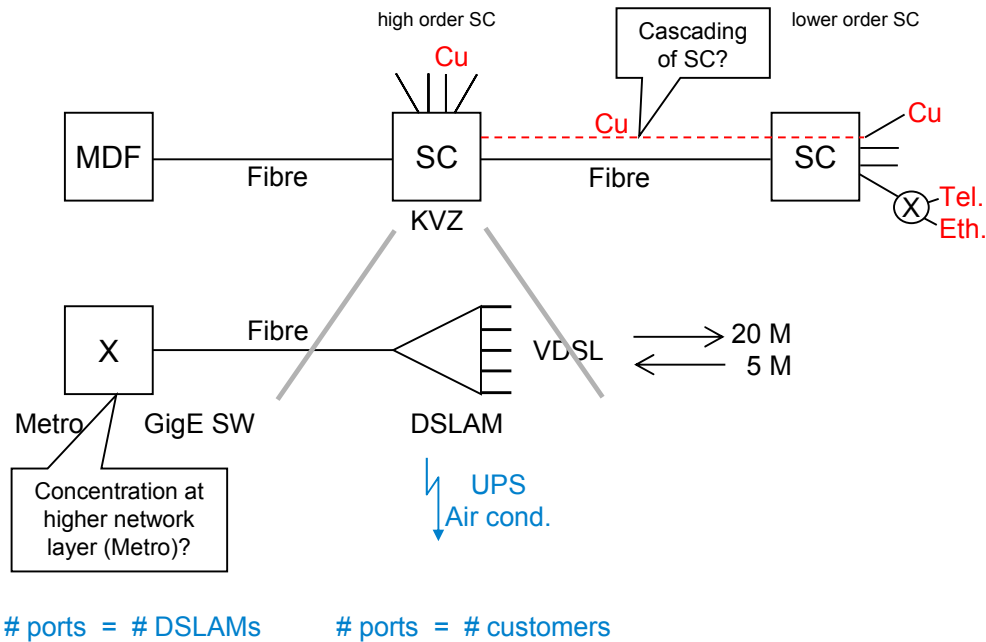

Source: WIK-C

Starting at the end customers the model considers the cost for the Customer Premises Equipment (CPE) with an integrated VDSL port and up to 2 telephone access ports and 4 Ethernet interfaces for the customer equipment. The sub-loop to the DSLAM is rented for the regulated wholesale sub-loop unbundling fee. One time costs are taken account of by a mark up of 20%. We consider the exchange of the street cabinet, which now needs electrical power, an uninterruptible power supply (UPS) and air conditioning. The DSLAM inside will be expanded with customer port cards according to the market share reached. The maximum size of the DSLAM can be selected and support up to 480 Ports typically. The DSLAM is connected per fibre pair up to the metro core location, where the fibres pass an optical distribution frame before they are connected to the Ethernet switch. The cost for these ports in the MCL switches are the final cost component of the access network. The other cost of the MCL is considered in the cost for the concentrator network.

In the case a second mover intends to roll out a separate VDSL infrastructure he needs to collocate at, or access, the street cabinet in order to obtain unbundled access to the (copper) sub-loop. The common use of the same street cabinet can be considered by selecting a parameter. In this case the cost for the street cabinet is increased by a parameter (which might be varied, default 15%) for the cabinet and the power supply

and air conditioning (default 35%) and then divided by the two parties (50% each⁷⁰). Otherwise a second street cabinet will be installed which then has to be connected to the incumbent's street cabinet (the street distribution frame in the SC), known as virtual collocation.

The amount of fibres needed determines the amount of fibre cables and consequently the amount of subducts needed.

In our model the standard duct infrastructure considers a trench with 2 ducts of 100 mm diameter, which is subdivided into 4 subducts, each being able to contain one cable of 148 fibre pairs. The model allows to deviate from these assumptions, if other standards have been explicitly implemented. Besides the ducts, manholes, handholes and sleeves/ bushes are considered in a parameterized manner for each of the clusters and segments. This infrastructure may be used by different usages. It is e.g. very likely that the infrastructure of the distribution area can be used for the feeder cables (between the street cabinet and the MDF site) as well and it may be used for the cables in the segment between the MDF site and the MCL (metro core location), which we call the backhaul segment. Likewise, in some parts there may exist the possibility to share the construction of trenches and ducts with other operators or utilities. The model allows to consider the common use of infrastructure independently in each of the clusters (Table 6) and for each of the three segments (distribution, feeder, backhaul).

In many countries it is not unusual to use aerial cabling in the distribution segment, notably in the less populated (e.g. rural) areas. The model allows to consider this case: there are two parameters the one denoting the percentage of homes per cluster being accessed by aerial cabling, the other reflecting if this infrastructure is used in a shared manner.

In addition, the amount of ducts being rented from others may be considered as a percentage per cluster.

For all fibre cables we do not consider pure buried cables, rather we concentrate on the use of ducts or aerial installation. The use of ducts in the distribution cable segment improves the possibility to exchange the cables in the case of repair or to add cables in the case of additional capacity needs.

4.1.2 The FTTH PON model

FTTH passive optical networks (PON, Figure 20) are characterized by fibre cables down to each customer home (apartment, dwelling). These fibres are concentrated in optical splitters onto one single fibre, which then is terminated in the metro core location

⁷⁰ One might discuss other shares, e.g. per amount of customers connected.

on a so called Optical Line Terminator (OLT). At the customer side the fibre terminates in a so called Optical Network Unit (ONU) in the case of multiple customers or Optical Network Terminator (ONT) in the case of a single customer. We refer in this study to both cases as ONU. Downstream optical signals are transmitted from the OLT in a broadcast manner over the single fibre to the splitter, where they are mirrored onto all end customer fibres and received by all ONUs. An ONU addressed transfers the signal to the customer equipment connected (e.g. telephone or Ethernet port). The ONU is connected to the concentration network via Ethernet ports (10 Gbit/s). The upstream signals up to the OLT should not collide on the single fibre between the splitter and the OLT. The OLT therefore may assign transmission rights to ONUs if requested. Because of this internal PON protocol between the OLT and the ONUs the transmission capacity of the system is limited and shared between all users connected. In a state of the art GPON system the downstream bandwidth (shared by all customers behind the splitter, i.e. in current implementations typically 32 or 64 customers) is limited to 2,5 Gbit/s and upstream to 1,25 Gbit/s. This may change over time, requiring, however, the replacement of all the electronic systems connected to the same tree.

The splitters may be cascaded, as shown in Figure 20. Thus, this approach enables to connect e.g. all customers of a building in the basement or several buildings at a point similar to the street cabinets. The sum of the customers connected should not exceed 64 (state of the art) per OLT splitter string (fibre) (e.g. one splitter with 1:64, or two layers with 1:8 each, or 1:32, ...). The splitters are pure passive optical components which need no power supply. They may be installed in a street cabinet, a man- or handhole or they may be buried (in a sleeve). The model allows to consider these options, but it restricts cascading to one splitter outside the building and one in the basement.

Figure 20: FTTH PON architecture: Illustration

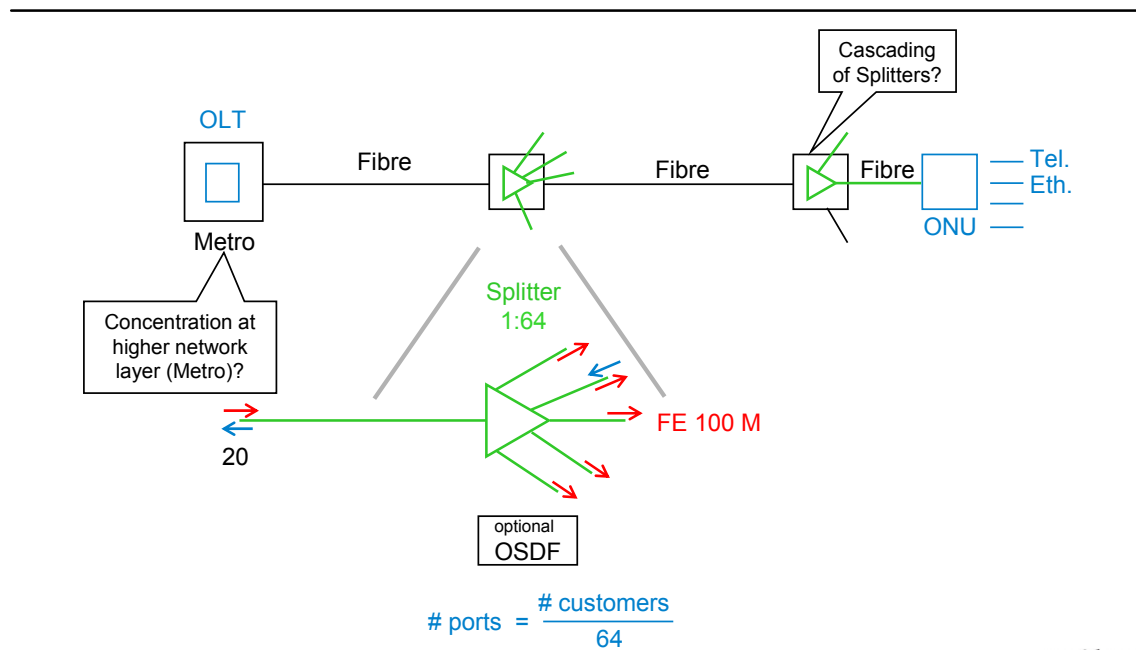

Source: WIK-C

In the case a second mover intends to roll out a PON infrastructure, instead of duplicating the infrastructure, it might share the already existing fibre end lines (distribution cables and drop cables⁷¹) from the splitters down to the customer homes. This requires the splitter location and the distribution fibres to be accessible, which can e.g. be implemented by installing a street cabinet and an optical street distribution frame (OSDF, Figure 21). In this case an additional cascaded splitter in the basement would prohibit the individual unbundling of an end customer. The unbundling of the fibre sub-loop is comparable to the unbundling of the copper sub-loop in the case of VDSL. An advantage of sub-loop unbundling is cost reduction through the common use of the distribution layer, including the inhouse cabling, which has to be fibre in the FTTH PON scenario.

⁷¹ Actually, one can distinguish between the distribution cables between the street cabinet and the pedestal and the drop cable between the pedestal and the basement of the customer premise. In this study we refer to both as distribution cable.

Figure 21: Fibre sub-loop unbundling in the case of PON: Illustration

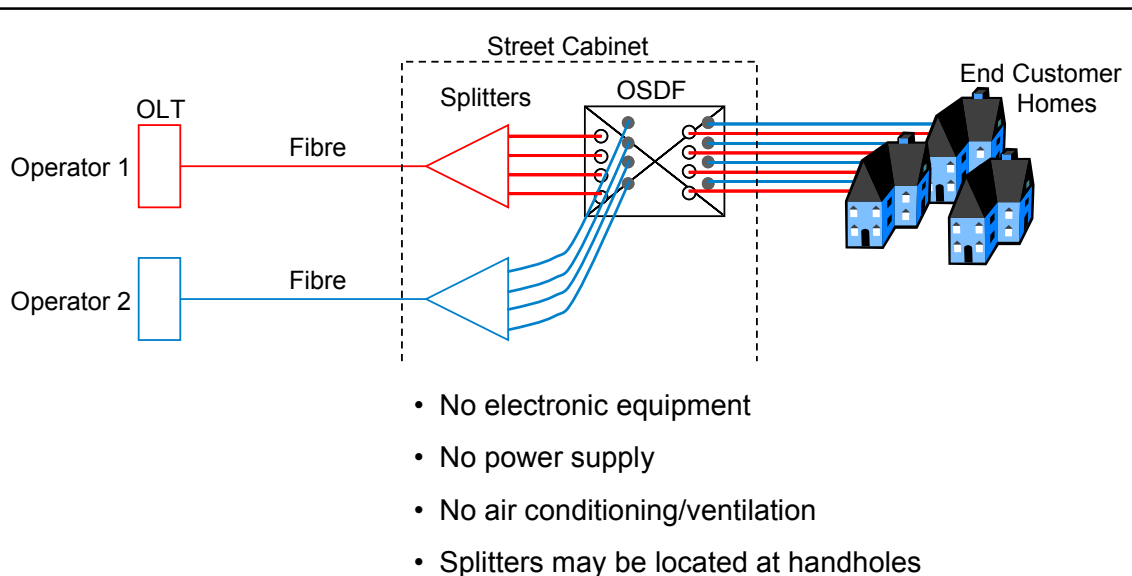

Source: WIK-C

The model allows to select this option by setting the appropriate parameters. The costs for the street cabinet are then increased and divided by the two operators, the cost for the OSDF in the street cabinet is divided according to the ports used (see below). Power supply and air conditioning are not needed due to the passive nature of the equipment installed.

At the end-customer side the model considers the cost for the ONU with its telephone and Ethernet ports, for the inhouse cabling in the cases where it has to be installed by the network operator, the splitters (allowing different parameterizations regarding basement, outside buried or in a SC with OSDF), the required amount of fibres and cables over the three network segments as described for VDSL (4.1.1), and for the ODF and ONU on a port base (per splitter string, fibre). The port in the Ethernet switch of the concentration network is the last element considered in the subscriber access network.

The O(S)DF capacity is configured as needed: the end customer side is installed for 100% of homes connected. The splitter side is installed according to the market share reached plus 10% spare capacity. Unlike in the buried case, where the splitters are fixed connected to 100% homes covered, in the shared case only that amount of splitters is considered which is needed to serve the assumed market share (plus a spare of 10%). This adapted installation then is also considered in the upstream fibres etc. and at the MCL ODF, OLT and Ethernet switch ports. Thus the shared use of the sub-loops allows for significant savings, because the OSDF allows to flexibly connect the customers to the equipment instead of fixing inactive potential customers to spare capacity.

4.1.2.1 WDM PON and TDMA-WDM PON

Using one optical fibre for several customers can be done in technologically different manners. PON technologies use the same single optical beams and assign transmission rights to end users by a central administration (sited in the OLT at the central site), so that each user can send his upstream information exclusively and without interference to other users in the same system in different time slots (TDM, Time Division Multiplex). WDM (Wave Division Multiplex) systems, however, use different optical beams of different wavelengths (different colours) to separate the transmitted information from each other. There are two types of WDM: Coarse WDM (CWDM) which works with cheap interfaces but only supports up to 18 different wavelengths, and Dense WDM (DWDM), whose interfaces are significantly more expensive, but offer up to 162 wavelengths, each being able to transmit up to 10 Gbit/s.

The combination of PON and WDM might overcome some of the disadvantages of a pure PON solution:

- PON systems can only provide a digital transmission path which is shared between the users, and therefore corrupted user equipment can affect the traffic of all other participants. PON systems, thus, inherently determine the quality of the digital transmission path of all customers.
- Due to the protocol needed between OLT and ONUs the capacity of PON is limited (e.g. GPON shares 2,5 Gbit/s downstream with up to 64 users).
- Due to the protocol between OLT and ONUs a second mover and competitor can only get access to the customers at the MCL in the form of wholesale bitstream access, and fibre SLU only is possible with collocation at the splitter sites. Bitstream reduces the ability of competitors to differentiate their products, collocation at the splitter level is expensive, particularly for market entrants.
- PON at the moment only supports a splitting ratio of up to 1:64.

A WDM PON could result in offering each customer ONU a separate colour. This would offer independent optical channels which cannot affect each other and which offer the full bandwidth of an optical beam (up to 10 Gbit/s)(Figure 22). Furthermore, it is easier to unbundle a colour beam than a PON customer signal, which is protocol dependent and therefore only offered as bitstream. The combination of WDM and TDM PON could in addition increase the splitting ratio dramatically (Figure 24, Figure 25). While with CWDM solutions the number n in the figures may only be 9 (one colour for each transmission direction within PON), it may rise with DWDM up to 80. From the perspective of future unbundling and independence Figure 24 and Figure 25 offer the optimal solutions: Each operator has its own colour(s), on top of which it implements an

independent PON access network. Some solutions need active splitter⁷² locations, which increase the cost (for electrical power etc.).

Figure 22: Simple WDM PON : Illustration

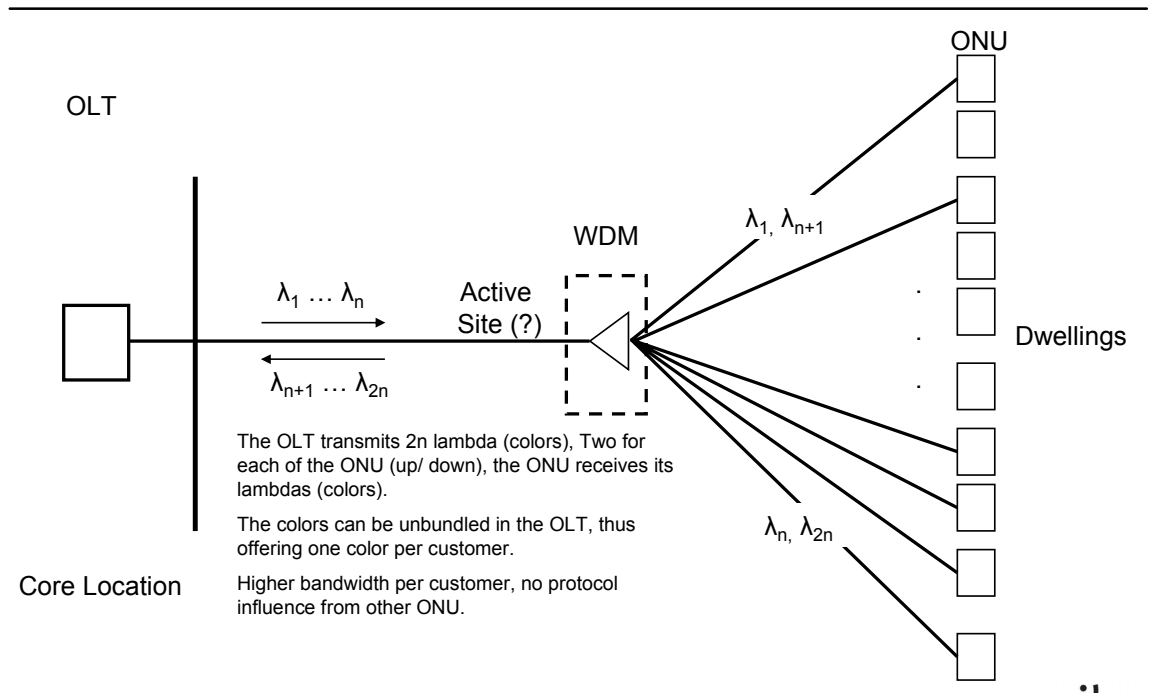

Source: WIK-C

⁷² Or active wavelength filters are required.

Figure 23: Simple WDM PON with λ -filtering ONUs: Illustration

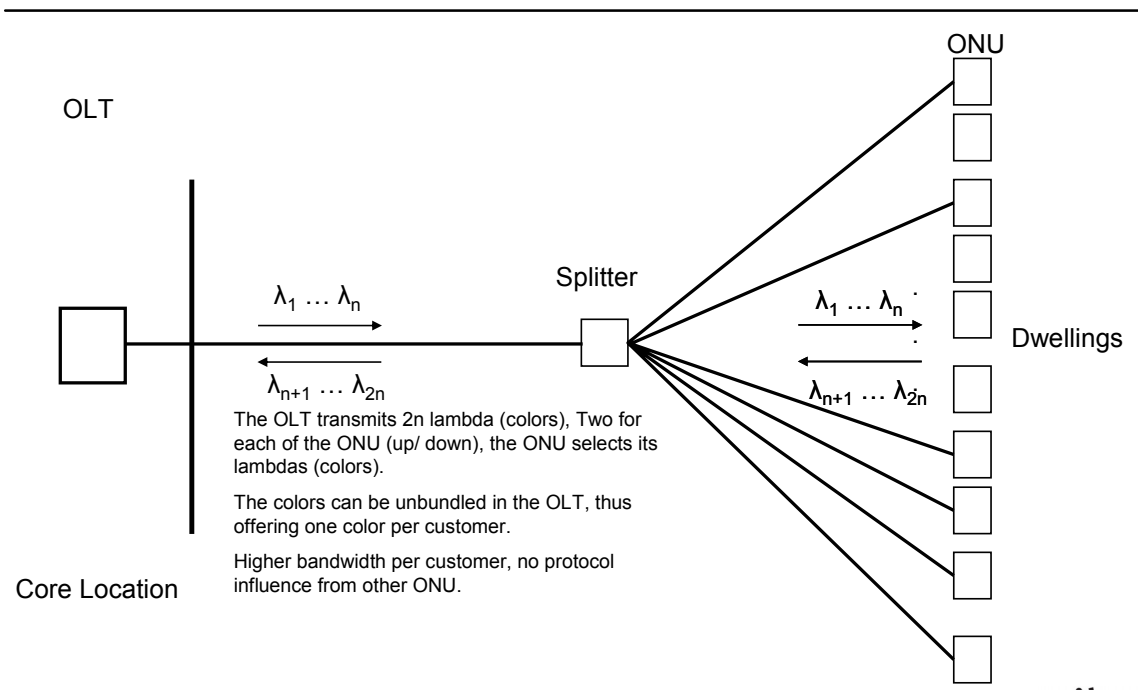

Source: WIK-C

Figure 24: TDMA PON with xWDM PON, regional groups: Illustration

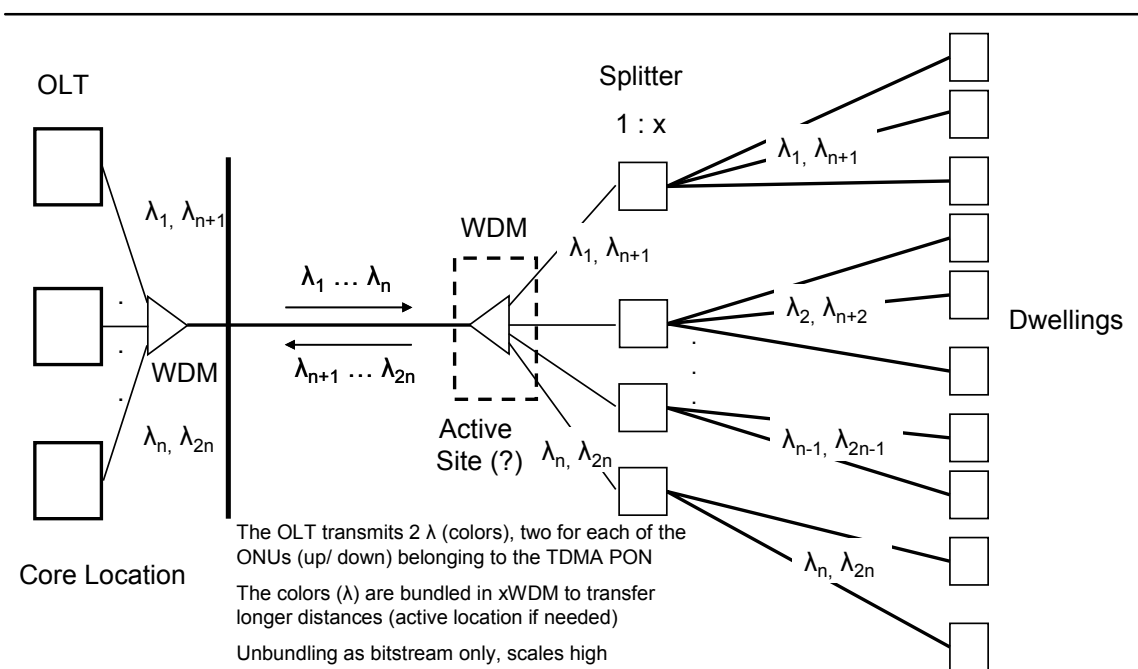

Source: WIK-C

Figure 25: TDMA PON with xWDM PON, operator oriented groups: Illustration

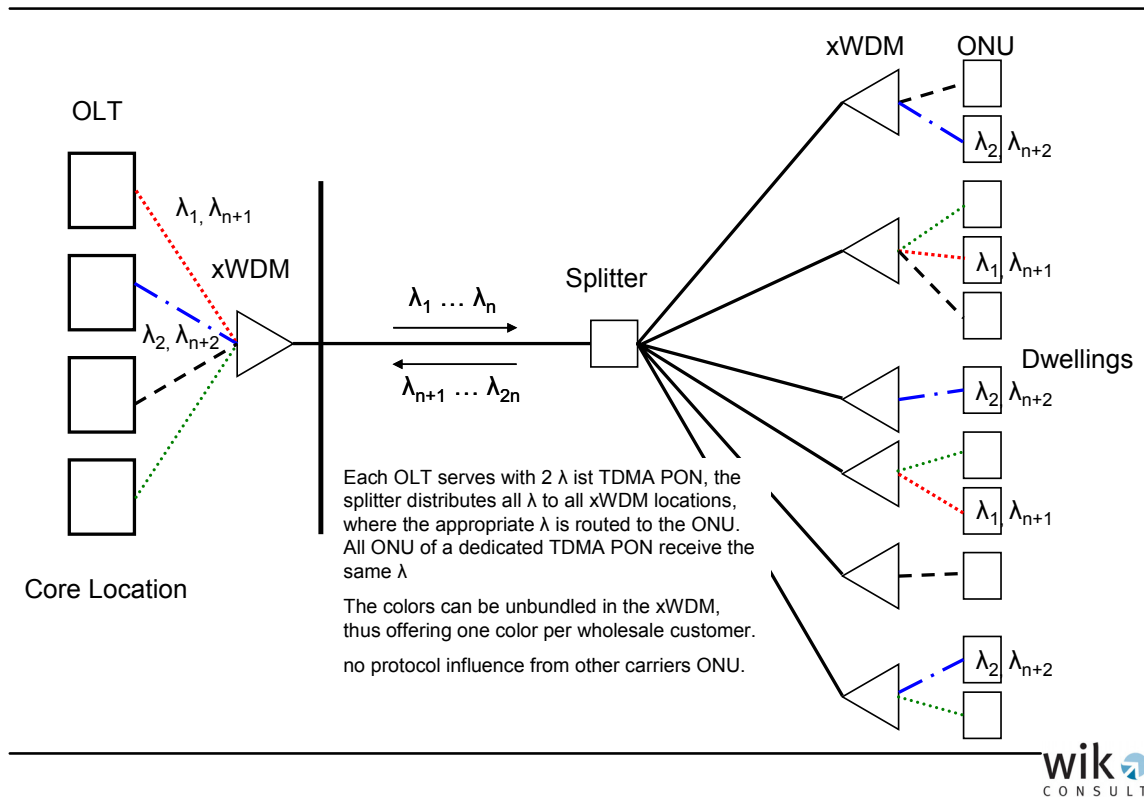

Source: WIK-C

Common for all solutions is that the PON equipment standards use optical beams that do not fit into the CWDM or DWDM Grids (wavelengths) of the ITU-T standards or even supply wavelength filters. In the short term it can be expected that only proprietary solutions are available. Prices, in turn, are likely to be rather high compared to standard GPON equipment because of the low quantities.

Deploying WDM equipment helps to overcome fibre scarcity. It is economically feasible where the construction of additional fibre is more expensive than the installation of a WDM solution⁷³. This is likely to be the case on a limited amount of lines in a network, but not as a complete architectural approach. A competitive operator constructing new infrastructure can install the appropriate amount of fibre for the architecture chosen. Thus, fibre scarcity should not occur. In this case WDM only is an economic solution if the installation of WDM is cheaper than the equivalent fibre increment from the scratch. For the time being the WDM solutions appear expensive.

Because of these reasons (lack of standardization, price) it is not yet the time to consider WDM variants of PON networks as a general technology in our study, but it is

⁷³ Another aspect may be time to market. Installing WDM may be faster than installing additional fibre.

worth to keep them in mind for the future. For deeper analysis we refer to the literature⁷⁴. There the equipment cost per customer is estimated to be higher than in a GPON solution even under the assumption of a significant decrease of cost because of an increase in quantities. Thus this seems to support the role of WDM in the case of fibre scarcity, but not in the case of a Greenfield approach.

Besides the discussion of WDM use in PON environments we want to suggest that WDM may as well help to overcome fibre scarcity in VDSL solutions.

4.1.3 The FTTH Point-to-Point model

FTTH Point-to-Point (P2P, Figure 26) deploys fibre access lines to each of the customers' homes (apartments, dwellings). Unlike PON, here the complete fibre capacity is available for each customer in the subscriber access network. Because of the uncertainties of the future bandwidth need of residential customers this appears to be the most future proof solution. Beside that, already now an increasing number of business and wholesale customers need direct fibre access. Within the wholesale demand it is very probable that there will be increasing requests for fixed broadband access (≥ 100 Mbit/s) to the base stations of mobile operators. Thus these connections could be served within the same access network architecture.

Figure 26: FTTH Point-to-Point: Illustration

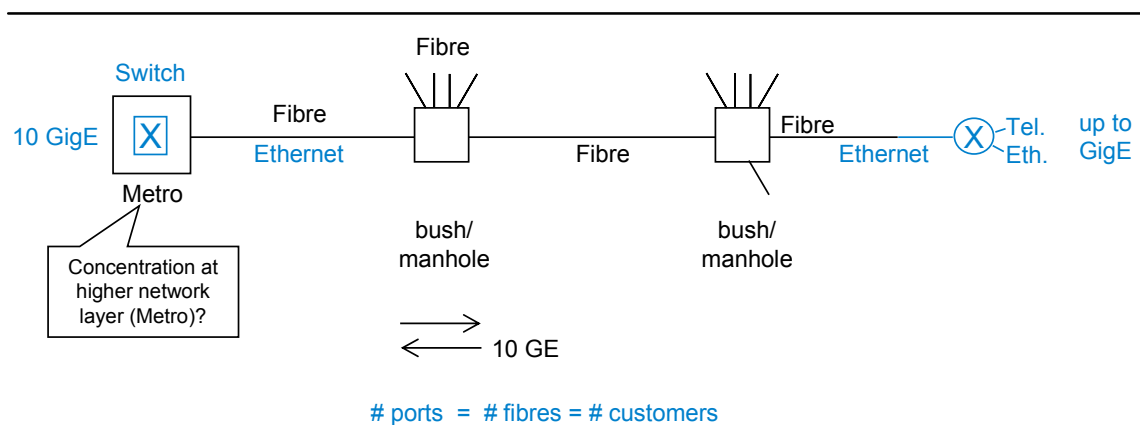

Source: WIK-C

The costs in this model variant consider the following network elements of the subscriber access network: The fibre at the end customer is terminated by a CPE router

⁷⁴ See e.g. Grobe and Elbers (2008).

with telephony and Ethernet interfaces, which transparently communicates with the central switch in the metro core location via Ethernet. While in the VDSL solution there is a port reduction for the central switch ports determined by the average number of customers per DSLAM (default up to 1:480) and in the PON solution there is a port reduction determined by the splitter ratio (typically 1:64), in the P2P case there is no reduction. The model assumes all homes of an area to be connected by a fibre. The fibre starts as inhouse cable (considered, if not paid by the house owner) and is then 1:1 routed through the access network using cables and ducts as described already in the VDSL solution (section 4.1.1). Of course at the backhaul layer⁷⁵ now a major amount of ducts is needed. The fibres are terminated in the MCL at the network side of the ODF. Only those fibres connecting active customers will be patched to the switch side of the ODF and then to the concentrating Ethernet switches. Thus the considered market share determines the need of the switch sided ODF ports (plus 10% spare) and the switch ports.

4.1.4 Consideration of regulatory measures

We consider the following regulatory measures for second movers in the model:

- use of subducts (empty ducts)
- shared use of aerial infrastructure (poles, façade mounted holders)
- use of dark fibre in the different network segments (e.g. for backhaul)
- collocation at/ sharing of the street cabinets (in the case of VDSL or FTTH) and shared use of the OSDF (in the case of PON)
- use of an unbundled sub-loop (copper in the case of VDSL, fibre in the case of PON (fibre SLU))
- use of an unbundled fibre local loop (in the case of P2P (fibre LLU)).

The unbundled use of subducts (being able to carry one cable) is considered as duct rental. The rental fee is calculated as the total cost for ducts, divided by the amount of used subducts in the different network segments and clusters, annualized as cost per subduct, meter and month. The amount of subducts needed is calculated out of the amount of fibres needed to deploy the network. The rental fee is calculated per cluster, if it is not regulated in a different manner. One should keep in mind that we assume that 100% of the potential market will be connected by the chosen access network architecture.

⁷⁵ See Figure 17.

The shared use of aerial cabling infrastructure is considered by just sharing the cost between the two operators in equal parts. Sharing of aerial infrastructure by a second mover is possible wherever the incumbent uses aerial cabling. Theoretically a second mover could use less aerial infrastructure than the incumbent, but in practice we assume the second mover to use as much aerial as possible, because it is cheaper.

The use of dark fibre is considered as fibre rental. The rental fee is calculated as the total cost for ducts and cables of the incumbent, divided by the amount of used fibres in the different network segments and clusters, annualized as cost per fibre, meter and month. The amount of fibres needed is equal to the amount of fibres needed to deploy the network. The prices of the fibres are calculated per cluster. One should keep in mind that we assume that 100% of the potential market will be connected by the chosen access network architecture. That is e.g. in the case of PON: all fibres needed to connect 100% of the homes are already rented in the distribution segment. In contrast to that Fibre SLU only rents the fibres needed to connect the contracted customers.

The calculation of the sharing of the street cabinets is already described in the appropriate cases above (VDSL and PON). The cost are increased compared to a single usage and then divided by two.

The cost for SLU and LLU are derived from the incumbent business case similar to the cost of the fibre. But instead of calculating it per network segment and cluster, the cost of the SLU and LLU are calculated out of the total cost over all relevant network segments and those clusters, where the incumbent business case is viable (so that one can assume that he will install fibres over there). The relevant network segments for the fibre LLU last from the end customer to the metro core location (MCL).

Beside that, a first mover has the possibility to commonly construct trenches and ducts with other operators and utilities and to construct aerial infrastructure wherever the incumbent does so.

4.2 Our overall model approach: characterization

Our basic modeling relies upon the Long Run Incremental Cost (LRIC) approach in a bottom-up manner. That means we model the total cost of the services considered under efficient conditions, taking into account the cost of all network elements needed to produce these services.

We consider three different types of players in the NGA market:

- first mover, not being the incumbent
- incumbent as first mover
- second mover

They may deploy their NGA networks in one or the other of the above described technical architectures (VDSL, PON, P2P, chapter 4.1). We assume that these players will serve all customer groups:

- residential, single play: voice
- residential, dual play: voice and internet
- residential, triple play: voice, internet and IP-TV
- business, mixed broadband services (VPN, Internet, Voice, ...)

Additional services (e.g. video on demand, gaming, ...) are not modeled, but could be included by adding an adequate margin of these services only (and not the additional total revenues), since the cost are not contained in the model either.

The **first mover, not being the incumbent**, has to roll out the NGA network to those areas (clusters) where the business will be viable, in a greenfield approach. It can take a first mover price for its services.

The **incumbent as first mover** will as well roll out the NGA network in the viable areas. It may have some advantages in sharing its infrastructure for telecommunications services not being considered in this model (like leased lines). Furthermore it gains an extraordinary income by closing down and selling the MDF locations no longer needed⁷⁶. It receives the same retail prices as we have assumed for the other first mover.

The **second mover** also covers the relevant clusters with a second broadband infrastructure, being able to cover 100% of the homes in that area. But depending on the regulatory options (chapter 4.1.4) it does not need to construct all infrastructure on its own, but could rent parts of the infrastructure (ducts, fibres, etc.). Unless we assume the option of SLU or LLU the second mover has to provide for the availability of fibre (rented or constructed) to all homes. We assume the retail price a second mover may achieve to be less than the prices for the first movers by 10%.

⁷⁶ The extraordinary revenue of the MDF sale reduces the investment needed per cluster (and is therefore distributed over time by reduced depreciations). The average sales revenue per MDF and country can be chosen and is set by default to 1 mill. € (KPN reference), except Portugal and Spain (0,5 mill. €).

4.2.1 Static modelling

The model approach we have chosen is static. We compare the cost of the NGA business in a future year and compare it with the income received for a dedicated market share. Increasing the market share percent per percent and comparing the resulting revenue per customer with the cost per customer we determine the point, where, if at all, the income equals the cost. This is the critical market share above which the NGA business is profitable.

In reality every operator entering the new NGA business will experience ramp up cost until it reaches this critical market share. To neglect this cost underestimates the real cost experienced and even increases the effective market share needed to recover the ramp up cost. Thus our results have to be interpreted as the minimum share needed, the reality might be worse concerning viability and replicability.

Of course choosing this static approach neglects to consider the different dynamics of the market players. Usually the incumbent starts with a very high market share, especially if one includes the wholesale access business. On the contrary, a first or second mover, which is not the incumbent, normally starts with a lower market share or in exceptional cases even from the scratch. Thus, the ramp up cost for the incumbent will be lower, increasing the gap described in the results.

4.2.2 LRIC greenfield and existing infrastructures

The LRIC approach implies to consider all costs incurred for the production of the services, e.g. those for all ducts needed. We have taken this approach for all cases considered. While for the competitive operators, as first or second movers, this will describe the cost they really experience because they newly construct, for an incumbent the situation is different. An incumbent may use already existing infrastructures like ducts or buildings. If these are not depreciated yet they are related with cost. When they are already depreciated, only minor cost would incur. In both cases the use of already existing infrastructure changes the point of view for the economic decision to roll out a NGA network (e.g. time to market, architectural decisions, ...) and may improve the economics itself, lowering the really needed critical market share and allowing to roll out in areas which might not be viable under a full cost consideration.

Since all results we present are based on the LRIC approach the costs for all infrastructure needed is considered as well in the incumbent case. They may be taken as opportunity cost. For the interpretation of the results one should keep these circumstances in mind.

4.2.3 Customer demand and market shares

We use the customer demand in the model in two dimensions. The first is the share or mix of demand for the different types of services (single play, double play, triple play, ...), the second is the market share the operator achieves and serves for the customer mix.

The customer mix in our model is not based on market research, but on reasonable assumptions, how many customers may remain with single play, how many will take up double or even triple play. For business customers we took the average proportion of business customers of 10% of the residential. The default relation within the residential customers for single, dual or triple play is 20%, 65% and 15%, but the model can be adjusted to adopt different proportions.

The market share an operator achieves is not based on any assumptions, because the way we model the results of viability uses the market share as a variable, being increased as long as the cost are still higher than the income in a specific cluster. The result is the critical market share needed to reach viability. Compared to other models the market share therefore is not an input, but the main output variable. Thus the question an operator in our model world might answer is not: 'what is the probable market share I can reach' (and put it into the model, e.g. to calculate the NPV), but rather: 'is it possible to reach even more than the critical market share the model gave me as output'.

The market share we use to determine the critical point is a share of all possible customers, of all residential homes or households plus a mark up of 10% for the business customers. This possible market includes as well all households using Cable TV operators instead of traditional fixed network operators, mobile-only households or households, that even do not have any telecommunication services at all. Only a part of it will be the market for broadband services. Hence the addressable or the broadband market are smaller than our total market base. This has to be kept in mind interpreting the market share we use in our study.

4.3 Model input

The model itself is based on WIK's long standing experience in LRIC bottom-up modeling and our network engineering experience. But a generic model needs concrete data.

ECTA commissioned WIK to calculate concrete results for six European countries: France, Germany, Italy, Spain, Sweden and Portugal. Thus we collected the data input needed to feed the model, especially the national particularities from ECTA members, and partly from regulatory authorities and other sources in these countries by a

questionnaire. Responses to questionnaires were followed up by several interviews, concentrating on specific details.

We used these interviews also to reflect the network architecture assumptions in each country and to get a realistic overview of the actual market developments and drivers regarding the deployment of different broadband access technologies. This enabled us to get a more substantiated view on the conditions actually influencing the business cases in each country (e.g. high sub-loop lengths (France), manholes instead of street cabinets with poor option to enlarge the space or to cool down the heat emitting DSLAMS on behalf of the competitors (Spain)).

The model operates for the 8 clusters described in Table 6. Some of the input parameters are cluster independent (e.g. ARPU), but most of them are cluster specific and have to be chosen for each cluster individually.

The input parameters to determine the **revenue side** of the model are the ARPU per each customer group (single – triple play, business) and their relative shares. A cluster dependent input value is the amount of households in each cluster.

The **cost side** of the model uses a very differentiated set of input values. Independent of the clusters are the values for the central network and services part (IP core network, concentrator network, IP-TV server/ service, amount of TV channels, bandwidth per TV-channel) and the values for MCL switches/ ports, O(S)DF ports and patch cables and fibre splices. All of these elements are considered in the cost model. The price for the sub-loop rental (for the VDSL cases) belongs to this group, too.

Main cluster specific values are the construction cost of ducts/cables, manholes, sleeves and aerial cables. The customer distribution per cluster is also relevant for the cost side, because it describes the amount of homes connected per cluster. Knowledge about the structure of the existing copper network per cluster is relevant in order to estimate the trench lengths needed for the NGA network. To this end, we use the number of MDFs per cluster, the number of street cabinets per MDF, the number of homes per street cabinet and the average length of the distribution, feeder and backhaul cable segments, respectively. Taking the product of the first three of these variables and summing up over the clusters yields a variable which allows to quantify the total number of possible subscribers. We used the number calculated in this way to check its plausibility against the available official statistical information. In cases where the deviations were perceived to be too big, we have adjusted the aforementioned network specific features.

A major part of the model configuration comprises the appropriate architectural and other parameters for the different access network solutions considered (i.e. VDSL, PON or P2P, first mover, incumbent or second mover and the regulatory measures). An overview of the scenarios considered is given in the following section.

4.3.1 NGA business cases considered

Because of the flexibility of the model and the amount of architectural and regulatory options, virtually a nearly unlimited number of scenarios and solutions can be produced. In order to be able to compare the results of the different approaches not only within one country, but also between the countries, we determined 21 standard cases per country (Table 7), for which we produced the critical market shares (for each of the eight clusters). To keep the architectural approaches (FTTC, PON, P2P) “clean” we did not mix them between the clusters or even within one cluster. We also restricted ourselves to a limited amount of regulatory options, which a priori seemed reasonable to us. Yet, even with these restrictions we produced altogether 126 cases. This number is reduced for those countries where VDSL is considered as being not/hardly feasible for technical reasons (i.e. France and Spain).⁷⁷ The cases can be selected by choosing the appropriate combination of input parameters.

The **stand-alone operators** acting as first movers are the base case of the model. They receive ARPUs as reported by the ECTA members. The only choice to be made is for the basic architecture (3 cases). No regulatory measures are included.

The **incumbent** as first mover is the first variation of the model which, however, does not require any regulatory options. We take account of the extraordinary income from the sale of a major amount of MDF sites by savings in the investment outlays, which then are distributed over time. Furthermore, we assume the incumbent to have a “competitive advantage” compared to competitors: the incumbent is assumed to be able to use its infrastructure for at least one additional purpose, i.e. the infrastructure can be used for providing (an) additional service(s) or product(s) (e.g. leased lines) which in turn allows a further cost sharing regarding the infrastructure. The ARPU is the same as in the basic stand-alone case.

The **second movers** are assumed to have 10% less revenue (ARPU) than the first movers. The reason is that it is harder for them to enter the market and they may not be successful by just having different (and better) services. Rather, our observation is that the market entry has to be supported by a price discount.

The **VDSL** cases for the **second mover** use sub-loop unbundling (SLU) in all of the cases considered, because the construction of new copper lines would never make sense. Hence all regulatory options considered only cover the backhaul and feeder segments of the subscriber access network.

The **PON** cases for the **second mover** allow the choice of using self constructed (or partly rented) or fibre SLU rented solutions. The first variants require a fibre

⁷⁷ To be more precise, we have reduced the number of cases for France by 8. In Spain we only calculated a single VDSL case, namely the one for the incumbent.

infrastructure to each of the homes covered, the SLU variant allows to rent just those fibre sub-loops which are necessary to connect the own customers. This is comparable to the standard copper SLU case (see VDSL). The regulatory options considered cover all three network segments, but with fibre SLU the solution for the distribution segment is already set.

Within the **P2P** cases for the **second mover** the model provides to choose between own (and rented) infrastructure down to the customer homes or rented loops (fibre LLU) at the metro core location. This is comparable to the existing copper LLU at the MDF sites although it may allow more replicability due to the smaller number of metro core locations than MDF sites. The regulatory options considered cover all three network segments, but with fibre LLU the solution for the distribution segment is already set as well.

The case **80% shared infrastructure** assumes an efficient regulation where the second movers can rent and share 80% of the infrastructure needed to install own cable from the incumbent or other market players (e.g. sewers owned by the City of Paris). The infrastructure to install cables can be empty ducts, sewers or aerial cabling poles or façade mounted holders, ...). Because of the cost differences we use the cheapest solution as long as it is available and add empty ducts up to 80%. Typically the relations differ from cluster to cluster (e.g. the less dense populated the more aerial installations are used). This approach is applied to all relevant network segments. The rest of 20% of the infrastructure has to be constructed by the second mover itself. In the case of VDSL (always with copper SLU) and PON SLU we assume the operators to share the same street cabinet.

The case **20% shared infrastructure** assumes a less efficient regulation or less availability of rentable infrastructure, but is comparable to the 80% case in all other dimensions. In the case of VDSL it is assumed that the less efficient regulation does not allow to realize the collocation in a single street cabinet. So a second one has to be installed. Only in the case of PON SLU the collocation in the street cabinet is assumed (you only need the SC with OSDF for realizing the SLU).

The case **80% dark fibre access** assumes an efficient regulation where the second mover can rent the amount of dark fibre needed instead of ducts. The amount needed differs between the architectures, since they reduce the fibre demand at the feeder and backhaul segments to a different degree. We only consider cases of dark fibre access in combination with VDSL and PON SLU⁷⁸. The fibre price differs between the clusters and considers the different construction approaches and cost of the incumbent (e.g.

⁷⁸ In the cases of dark fibre access without LLU/SLU it is assumed that all fibres to connect the homes of a cluster are rented or constructed in advance, and anyhow are available independently of the market share achieved. This makes these cases very expensive and we excluded them from the considerations here.

aerial). Once again in the case of VDSL and PON SLU we assume the operators to share the same street cabinet.

The case **20% dark fibre access** assumes a less efficient regulation or less available infrastructure, but is comparable to the 80% case in all other dimensions. In the case of VDSL it is assumed that the less efficient regulation does not allow to realize the collocation in a single street cabinet. Thus, a second one has to be installed. Only in the case of PON SLU the collocation in the street cabinet is assumed (you only need the SC with OSDF for realizing the SLU).

The case **80% dark fibre/ shared infrastructure** incorporates a combination of duct rental in those segments, where the amount of fibres in parallel is high, and fibre rental, where it is low. We only consider this in combination with SLU cases (PON, VDSL), so the ducts are rented in the backhaul segment (MCL – MDF) and the fibres are rented in the feeder segment between the splitters/ street cabinets and the old MDF locations. This variation may reveal that a differentiated approach can be cheaper than a pure approach (e.g. duct rental only).

Table 7: Main assumptions characterising the different cases of our model

		Remarks	
1	Stand Alone operator as first mover	VDSL	
		PON	
		P2P	
2	Incumbent as first mover	VDSL	(i) Investment savings due to dismantling of MDFs (ii) Better use of shared infrastructure
		PON	
		P2P	
3	2nd mover VDSL	80% shared infrastructure	(i) 10% less revenues than in (1) and (2) (ii) 80% of deployment is realized by using air cables and empty ducts (iii) 2nd mover and incumbent share the street cabinet
		20% shared infrastructure	(i) 10% less revenues than in (1) and (2) (ii) 20% of deployment is realized by using air cables and empty ducts (iii) 2nd mover uses its own street cabinet
		80% dark fibre access	(i) 10% less revenues than in (1) and (2) (ii) 80% of deployment is realized by dark fibres (iii) 2nd mover and incumbent share the street cabinet
		20% dark fibre access	(i) 10% less revenues than in (1) and (2) (ii) 20% of deployment is realized by dark fibres (iii) 2nd mover uses its own street cabinet
		80% dark fibre/shared infrastructure	(i) 10% less revenues than in (1) and (2) (ii) In the feeder segment: 80% of deployment is realized by dark fibres (iii) In the backhaul segment: 80% of deployment is realized by empty ducts (iv) 2nd mover and incumbent share the street cabinet
		20% dark fibre/shared infrastructure	(i) 10% less revenues than in (1) and (2) (ii) In the feeder segment: 20% of deployment is realized by dark fibres (iii) In the backhaul segment: 20% of deployment is realized by empty ducts (iv) 2nd mover uses its own street cabinet
4	2nd mover PON	80% shared infrastructure	(i) 10% less revenues than in (1) and (2) (ii) 80% of deployment is realized by using air cables and empty ducts
		20% shared infrastructure	(i) 10% less revenues than in (1) and (2) (ii) 20% of deployment is realized by using air cables and empty ducts
		80% dark fibre access + SLU	(i) 10% less revenues than in (1) and (2) (ii) 80% of deployment is realized by dark fibres (iii) 2nd mover and incumbent share the street cabinet (iv) Sub-loop unbundling is considered
		20% dark fibre access + SLU	(i) 10% less revenues than in (1) and (2) (ii) 20% of deployment is realized by dark fibres (iii) 2nd mover and incumbent share the street cabinet (iv) Sub-loop unbundling is considered
		80% dark fibre/shared infrastructure + SLU	(i) 10% less revenues than in (1) and (2) (ii) In the feeder segment: 80% of deployment is realized by dark fibres (iii) In the backhaul segment: 80% of deployment is realized by empty ducts (iv) 2nd mover and incumbent share the street cabinet (v) Sub-loop unbundling is considered
		20% dark fibre/shared infrastructure + SLU	(i) 10% less revenues than in (1) and (2) (ii) In the feeder segment: 20% of deployment is realized by dark fibres (iii) In the backhaul segment: 20% of deployment is realized by empty ducts (iv) 2nd mover and incumbent share the street cabinet (v) Sub-loop unbundling is considered
5	2nd mover P2P	80% shared infrastructure	(i) 10% less revenues than in (1) and (2) (ii) 80% of deployment is realized by using air cables and empty ducts
		20% shared infrastructure	(i) 10% less revenues than in (1) and (2) (ii) 20% of deployment is realized by using air cables and empty ducts
		LLU	(i) 10% less revenues than in (1) and (2) (ii) LLU is considered

Source: WIK-C

As sensitivity we add the expenditures of second movers for infrastructure rented from the incumbent to the incumbents revenues per cluster as infrastructure wholesale revenue and investigate the effect on the incumbent's critical market share and profitability.

4.4 Typical model output

The main result of the model is the critical market share needed for the viability of the NGA business for the first movers and under certain circumstances for the second movers as well (replicability). The calculation of the critical market share is done cluster per cluster; and the results for the clusters are independent from each other. Our concept is illustrated in Figure 27, which shows the cost curve and the average revenue of an operator in a particular cluster.

Figure 27: Determination of the critical market share for a single cluster: illustration

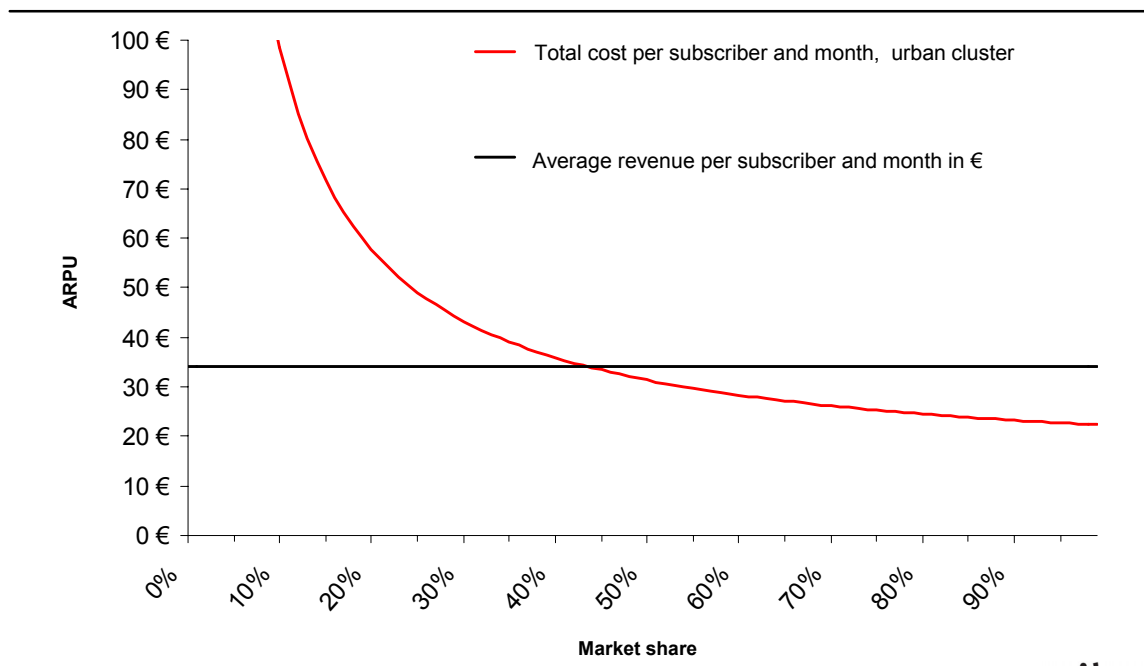

Source: WIK-C

The ARPU is given as an input parameter and is valid for all clusters. The total cost per subscriber and month for each cluster is calculated by the model dependent on the market share in this cluster. It is the scale effect of large amounts of users which decreases the cost per user with increasing market share. Increasing the market share

percent per percent may end, as in this example, by cutting the revenue (ARPU) curve at the critical market share. The model increases the market share up to 100%.

Achieving a market share of 100%, however, is not realistic, since the basis of 100% comprises all possible customers, including those being connected to Cable TV networks, mobile-only users and those which refuse to be hooked upon an electronic communications network at all. Thus, the results have to be interpreted accordingly. The results for all clusters may be combined as illustrated in Figure 28.

Figure 28: Critical market shares across different clusters: illustration

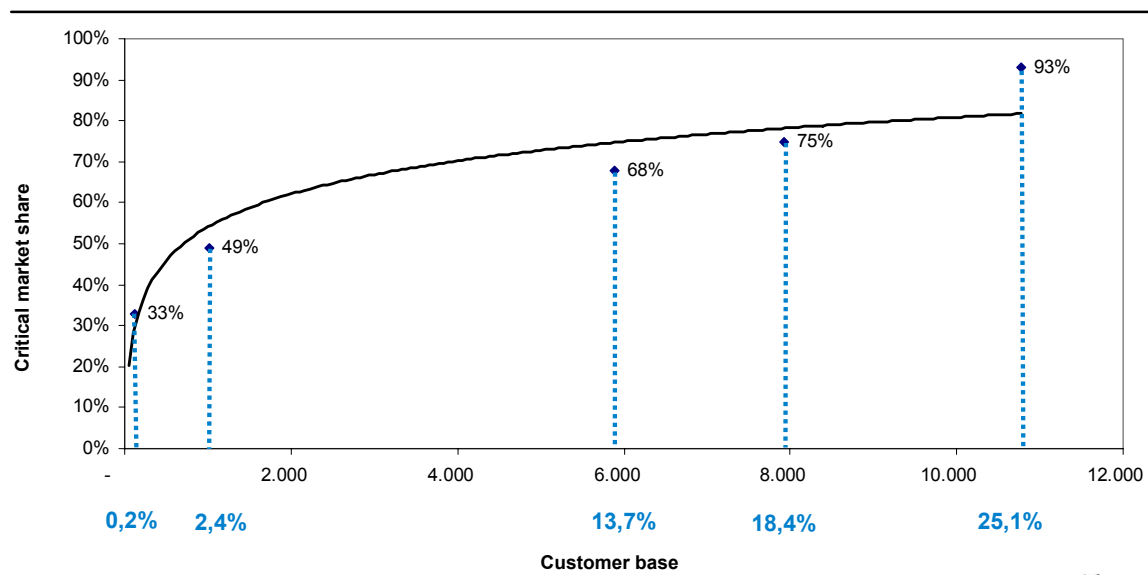

Source: WIK-C

Each of the points (on top of the blue dotted lines denoted with percentage values) reflects the critical market share of a specific cluster. The x- axis specifies a particular order of the potential subscriber (customer) base across the clusters: The order of the results (the order of the clusters) is ranked according to the decreasing subscriber density of the clusters. Thus, the result for the densest populated cluster (“cluster 1) is always presented on the utmost left hand side (the critical market share in this cluster is 33 %, 0.2 % of all customers live in this cluster). The result for the second densest cluster (“cluster 2”) follows next: (the critical market share in this cluster is 49 %). The respective value on the x-axis denotes the sum of the potential customers in both clusters. In our example below the aggregate share of the total customer base in the densest and second densest cluster is equal to 2.4 % and around 1 mill. subscribers live in these two clusters. In the example below the critical market share in the third densest cluster (“cluster 3”) is equal to 68 %; an aggregate customer base of 13.7 % equalling nearly 6 mill. subscribers lives in the three densest clusters and so on. The

diagram ends on the right hand side with the cluster where the critical market share still remains below 100%.

Once again, we want to stress that the critical market shares exhibited in this figure have to be interpreted as saying that *at least* 33 % market share are needed in cluster 1 (49 % market share in cluster 2, 68 % market share in cluster 3, 75 % market share in cluster 4) to make the NGA business in this cluster viable. The figures should *not* be interpreted as saying that all clusters up to cluster 2 need 49 % (up to cluster 3 68 %, up to cluster 4 75%) market share.

The curve above the different critical market shares is a logarithmic interpolation of the single points.⁷⁹ This curve aims at illustrating where the results might be if the clusters had been defined in a different manner or in different sizes. It is worth to stress that in our model there is no subsidy of denser clusters being taken into account to determine the critical market share. This approach, thus, allows to determine if an investment in the next less populated cluster is viable as such or not. Thus, we do not include any universal service considerations.

Concrete results for the different cases and the different countries as well as their appropriate interpretation will be given in chapter 5.

⁷⁹ One could take as well other methods of interpolation than the logarithmic one. Since the results are independent from each other and to some extent depend on the cluster sizes any approach to interpolate may lead to misinterpretations under certain conditions. Nevertheless, we choose this interpolation for illustration purposes.

5 Empirical evidence in Europe: Country results

This Chapter is devoted to specific country studies for

- Germany,
- France,
- Italy,
- Spain,
- Portugal and
- Sweden.

This Chapter, thus, consists of six sections, one for each country. Each section, in turn, consists of two sub-sections. First, we present a short description of the current situation regarding the strategic positioning of the key players in the market and the regulatory environment with respect to deep fibre deployment in the access network. These country specific sub-sections are not meant to be bottom-up case studies, rather, we confine ourselves to those issues which are most relevant within the framework and objective of the present study.

Second, we present the actual model results for these countries. With respect to the latter we address in particular the following issues having fed the generic model with country specific parameter values:

- the degree of replicability of VDSL and fibre access networks given and absent supporting regulation (e.g. with respect to fibre and duct access) and assuming no consumer price increase.
- Cost and price implications and the potential impact on geographic reach of the roll-out where multiple roll-out is made. To this end, we examine what is efficient from both a consumer and an investor perspective.

Moreover, our model evaluates the consequences of a combination of infrastructure sharing, access to ducts and dark fibre, collocation and fibre unbundling as a route to ensuring effective competition in retail markets. In addition, we address the issue of bitstream inputs on the basis that such services are necessary in addressing areas where infrastructure investment/unbundling is not economically viable and to enable the provision of pan-European and global services to multi-site businesses.

The model allows for Weighted Average Cost of Capital (WACC) variations to be applied. Some sensitivities regarding the WACC are presented as an example as part of section 5.2.2 containing the results for France .

Sensitivities with regard to the Average Revenue per User (ARPU) are presented as an example as part of section 5.1.2 containing the results for Germany.

We consider as an example the case of an incumbent getting additional revenues from the wholesale duct and fibre business with second movers and the effects of these revenues on its critical market share as part of section 5.4.2 focusing on the results for Portugal.

5.1 Germany

5.1.1 Market developments and regulatory background

5.1.1.1 Strategic positioning of the main players in the broadband market

Background

In Germany there are about 7,900 MDFs and about 380,000 street cabinets.⁸⁰ The average sub-loop length is about 300 m.⁸¹

The telco incumbent in Germany, Deutsche Telekom AG (DTAG), overall still is the company with the strongest market position. Indeed, empirical evidence shows:⁸²

- DTAG has a share of 48 % with respect to the overall (nominal) retail telecommunications service market volume. The market share of DTAG in the fixed-line market segment is higher and equals 62 % in 2007.⁸³
- With respect to telephony access lines DTAG has a market share of more than 80 % (81.4 %).
- DTAG has a share of slightly below 50 % (48.6 %) in the overall number of retail DSL lines. This figure relates to the number of retail customers subscribing to DTAG directly. Several competitors in Germany offer DSL access based on resale of DTAG services. Aggregating the direct market share of DTAG and the resale market share of competitors yields an overall market share of 67.6 %.

⁸⁰ According to other sources the number of street cabinets in Germany is slightly lower at around 330,000.

⁸¹ It is worth stating that this figure mirrors a national average. In reality it is likely that the average sub-loop length is lower than 300 m in (very) dense urban areas and that it is greater than 300 m in rural areas.

⁸² See BNetzA, Jahresbericht 2007, Bonn.

⁸³ The association of competitors (VATM) in Germany argues in a different way: Aggregating turnover of all competitors in the fixed-line segment, subtracting all wholesale payments to DTAG, and dividing the resulting sum by the total fixed-link market volume yields that DTAG has an estimated market share of 73.3 % in 2007.

However, competition in Germany has been increasing in the last years in the field of broadband access lines. This relates both to intra-modal and intermodal competition.

Deutsche Telekom AG (DTAG)

In 2006 DTAG launched the deployment of FTTC/VDSL infrastructure. VDSL a priori is a viable option in Germany for a relevant part of the country because the average sub-loop length is relatively short (see above).

As of May 2008 DTAG has deployed FTTC/VDSL infrastructure in 27 cities, and ADSL 2+ infrastructure in about 750 cities, thus, reaching around 17 mill. households⁸⁴. Until the end of 2008, a total of about 50 cities will be served by the VDSL network and ADSL 2+ will be available in about 1,000 cities. Thus, DTAG claims that overall 20 mill. households (about half of the overall number of households in Germany) will have DSL based high-speed broadband access⁸⁵.

There are perceived to be at least two driving forces for DTAG's FTTC/VDSL deployment activities:

- A desire to increase market share and counterbalance losses from the telephony market: In the past 2-3 years DTAG has lost about 2 mill. access lines p.a. to competitors (mainly replaced through services offered by competitors via unbundled local loops).
- Increasing demand for triple play services ((VoIP) telephony, broadband access, television), partly stimulated through more intense competition from unbundling and increasingly cable.

DTAG has thus responded to capital market expectations to sell a convincing new growth story, and to support its share price which has fallen in recent years and remains below the IPO quotation price in 1996. However, up until now the adoption of triple play services is far below expectations: As of mid-2008 DTAG has about 250,000 triple play customers.

There is as yet no confirmed public information about phasing out of MDFs. DTAG has declared that according to its plans this issue might become relevant from 2012 onwards and perhaps earlier for single MDFs. According to some recent press reports in August 2008, forced phasing out of MDFs can be expected from 2014 onwards. So far there is no final date for the complete migration communicated as it is the case for the Netherlands. It is the intention to replace the existing 7,900 MDFs by about 800 – 900 Metro Core Locations. The reports also state that DTAG expects to generate

⁸⁴ See <http://www.telekom.com/dtag/cms/content/dt/de/443114>.

⁸⁵ See <http://www.telekom.com/dtag/cms/content/dt/de/532336>.

3.5 bn. Euro additional income by selling the real estate of the MDF sites. Negotiations between DTAG and competitors on these plans are about to start in September 2008.

Until very recently, DTAG had not announced publicly any intentions to move to FTTB/H. However, in August 2008 press reports appeared stating that DTAG would migrate up to a third of the existing access lines to FTTB/H.⁸⁶

Telco competitors

DTAG experiences competition from a variety of other telecommunications companies. There are several different business models observable in the German broadband access market differing with respect to customer focus (retail, business customers, carrier's carrier), product and service focus (similar to DTAG, focused e.g. on business communication and/or wholesale services), geographic focus (national, regional/local) and with respect to own network infrastructure deployment (purchase of ULL, resale-based). Hereafter, we present information about the most important market players.

Several players in Germany have deployed their own network infrastructure up to MDFs and have installed ADSL/ADSL 2+ and SDSL DSLAMs and using unbundled local loops. The main facilities based competitors of DTAG in the German broadband market are

- Arcor (since May 2008 wholly owned by Vodafone, access to about 3,000 MDFs),
- Hansenet (brand name "Alice", home turf is Hamburg, however country-wide offerings (mainly based on QSC infrastructure) since about 2 years,
- QSC (establishment of a separate network infrastructure company "Plusnet" together with Tele 2; access to about 2,000 MDFs),
- Telefonica Deutschland (access to about 2,500 MDFs),
- Versatel (access to about 1,000 MDFs),
- Regional and local carriers (see below).

Moreover, there are also players in the German broadband access market which follow a less facilities based approach by relying on resale and wholesale broadband access services provided by DTAG and increasingly also on wholesale services purchased from other platform providers such as Arcor, QSC, and Telefonica. The most important player within this category with about 2.4 million customers and a market share in total DSL subscriptions of approx. 15 % is a company called United Internet (with its brands 1&1, gmx, and Web.de).

⁸⁶ See <http://www.wiwo.de/unternehmer-maerkte/die-telekom-vor-dem-totalumbau-304827/> and <http://www.wiwo.de/unternehmer-maerkte/telekom-obermann-plant-radikalen-netzumbau-304127/>.

The regional and local carriers have a special historical background⁸⁷. Many were founded in the mid 1990's by regional/local utilities anticipating opportunities for a business case in telecommunications due to the anticipated introduction of competition. Germany at that time had about 70 such "city carriers". Meanwhile, a substantial consolidation has already taken place so that the number of regional and local players has diminished (several of the former independent companies still exist, however, as a brand). As of May 2008 we estimate the number of (non-affiliated) city carriers at about 25. Arcor and Versatel have been prominent buyers of regional and local companies as well as EWETel (with its geographical home turf in the North Western part of Germany and in the new "Länder") and M'net (with its geographical home turf in Munich).

Apart from their ties with their respective regional/local parent companies the regional and local carriers mainly rely on a strong brand (awareness) as well as on knowledge of and responsiveness with regard to the specific needs of the regional/local retail and business customers. Thus, several of them have been able to gain a strong footprint in their home market in particular with regard to the ADSL market share. Examples are Hansenet in Hamburg with a DSL market share of about 50 %, M'net in Munich with a DSL market share of about 20 % and NetCologne in Cologne with a DSL market share of about 50%.

The aforementioned regional competitors in Hamburg, Munich, and Cologne and several others have launched or are planning to launch FTTB infrastructure.⁸⁸ These companies are concentrating their deployment activities on the densely populated areas of their regional home markets. The most important factor for their business case is savings from ULL wholesale services currently purchased from DTAG and an existing high market share that provides some certainty of continuing cashflows and an easy transition of customers.⁸⁹ Thus, a lower ULL price would have made these investments of the competitors more unlikely, but – on the other hand – would increase ULL-competitors' market shares significantly. Moreover, the local carriers involved in FTTB ventures might benefit from the fact that access to capital is easier for them due to their

⁸⁷ For more details see e.g. Metzler and Stappen (2003).

⁸⁸ NetCologne is focusing on Cologne and Aachen. M'net is focusing on Munich and Augsburg. Hansenet is focusing on Hamburg. WilhelmTel (owned by the utility company (Stadtwerke) of Norderstedt, a city in the North of Hamburg, is focusing on Norderstedt and parts of Hamburg. Stadtwerke Schwerte (the utility company of Schwerte, a city in Northrhine Westphalia) is focusing on Schwerte.

⁸⁹ Indeed, NetCologne is e.g. reporting that the overall investment costs for their FTTB network in downtown Cologne are 125 mill. Euros. Once deployed, this infrastructure will make NetCologne totally independent from purchases of wholesale services from DTAG which in effect saves them about 30 mill. Euro per year. The network will give access to 55.000 buildings with more than two apartments or with business usage. NetCologne has decided to deploy a FTTB network soon after the announcement of DTAG in the year 2005 to deploy a FTTC/VDSL network. According to NetCologne only their FTTB network allows them to compete in a long term with the VDSL products and services provided by DTAG and in parallel to react to the foreseeable phasing out of MDF locations. A FTTC/VDSL replication and purchase of wholesale services from DTAG at the street cabinet, so NetCologne argues, would also lead to high investment costs, however, it would not free NetCologne from depending on the infrastructure from DTAG. The latter objective, they conclude, is only possible on the basis of the FTTB approach.

affiliation with cash-flow rich utilities. It is arguable on this basis that the risk premium for debt may be lower than for local carriers that act on a stand-alone (i.e. unaffiliated) basis.⁹⁰

Once the FTTB infrastructure is deployed in the aforementioned cities, households will potentially have three options for high-speed broadband access: incumbent VDSL, FTTB by a city carrier and cable modem service by a cable infrastructure operator.⁹¹

Germany's FTTB activities seem mainly to rely on P2P approaches. Regarding in-house cabling usually the existing twisted-pair copper infrastructure is used on the basis of which a VDSL solution is implemented in-house. Market participants in Germany underline that the housing companies play a vital role regarding FTTB/H because only with their permission the respective access to the different apartments of their multi-dwelling units is possible. Usually access to the in-house infrastructure has been free of charge from the house owner.

Cable operators

Cable modem access still plays a minor role in the German broadband market, i.e. intermodal competition is still relatively limited. Indeed, the three major regional cable operators in Germany⁹² together account for about one mill. broadband access lines (as of December 2007) and a market share of about 5 %. However, the cable operators represent a potential threat to the telcos because they are also upgrading their networks in order to offer HFC (hybrid fibre coax) based triple play services. In May 2008 Kabel Deutschland had upgraded approximately 71 % of its total broadband cable coverage to HFC, passing 10.9 mill. German homes, Unity Media had upgraded 68 % of its network, reaching 5.9 mill. homes and Kabel BW had upgraded 91 % of its network passing 3.3 mill. households. Although the cable operators are latecomers in the German broadband market, they are expected to increase their market share. The most successful cable operator in Germany can attract more than 25 % of new broadband customers in its addressable market.

Backhaul and core network

Regarding availability of infrastructure for backhaul solutions the situation in Germany differs regionally. In geographic areas where city carriers are active it is today usually possible for a competitor to purchase infrastructure and/or managed services at least from two sources (DTAG, city carrier). In geographic areas, however, where no city carrier is active the alternatives are DTAG or self-construction.

⁹⁰ Part of the actual FTTB investments of NetCologne appear first in the balance sheet of the parent company. Only gradually the infrastructure is appropriated by the city carrier itself.

⁹¹ This may be different in Cologne where NetCologne also is a major cable operator.

⁹² There are mainly three companies owning cable network infrastructure in Germany: Unity Media (providing services in Northrhine Westphalia and Hestia), Kabel Baden Württemberg (providing services in Baden Württemberg) and Kabel Deutschland (providing services in the rest of Germany).

Regarding core network infrastructure there is one important player in Germany deploying fibre infrastructure and selling dark fibre to market players: GasLine, a consortium of 15 German gas transmission and regional distribution companies⁹³. Moreover, in the 1990s an excess of fibre was deployed for intercity connections which today is available for exploitation⁹⁴.

5.1.1.2 Regulation, *wholesale services*

§9a infringement procedure

The European Commission has launched an infringement procedure against Germany in view of a specific clause in the new telecommunications law opening up possibilities for “regulatory holidays” for DTAG’s FTTC/VDSL deployment (§ 9a of the Amendment of the Telecommunications Act). The outcome of this infringement procedure is still pending.

Duct access

As a result of the ongoing market definition and market analysis process BNetzA, the German regulator, in June 2007 has imposed an obligation on DTAG to open up the ducts between MDF and street cabinets for competitors. This obligation comprises ducts between different cabinets (linked cabinets) as long as these links are part of a link leading to the MDF. Competitors are, however, not entitled to access ducts to link PoP locations with the MDF. Where access to ducts between the MDF and street cabinets is not possible (e.g. due to technical reasons or limited capacity), DTAG must offer competitors access to dark fibre.⁹⁵ This obligation to offer access to ducts does, however, not cover duct access in order to deploy FTTB/H infrastructures. The aforementioned regulatory obligation comprises also the collocation within the street cabinet of the incumbent. In the event that there is insufficient space for collocation, a decision on a mandatory upgrade of collocation must be taken on a case-by-case basis.

Whilst these obligations have been imposed, detailed operational rules regarding the administratively efficient use of these access options and wholesale fees have yet to be established. Operational challenges regarding the implementation of this solution in practice (transaction costs) as well as the pricing issues still need to be resolved. Thus, access to ducts is currently not available in practice in the market.

Competitors in Germany view the decision by BNetzA regarding duct access as a step in the right direction. However, they claim that access to ducts is only one of the

⁹³ See Schäfer and Schöbel (2005).

⁹⁴ See Elixmann (2001).

⁹⁵ Of course this does not mean that DTAG is obliged to deploy fibre *for* competitors (on their request). Rather, competitors can get fibre access only to the extent that the dark fibre infrastructure is available.

elements needed for a viable business case. They indicate that dark fibre should be treated as an equal and not a secondary alternative. Alternative operators are also demanding the (bundled) access to the hybrid local loop, consisting of copper and fibre, at the MDF where own infrastructure roll-out is not economically viable.⁹⁶

Regarding duct availability and space there are still significant information asymmetries between DTAG and the competitors in the German market. Part of the aforementioned order of BNetzA in June 2007 was therefore to impose on DTAG the obligation to disclose information on the available alternative of access to its cable ducts or dark fibre, as well as information on the prospective own VDSL roll-out to the street cabinet in question. DTAG submitted an appeal to the Cologne Administrative Court concerning the June 2007 order of BNetzA. The Court concluded in April 2008 that the access obligations as such could remain effective. However, the obligation to disclose information on future VDSL roll-out plans was suspended by the Court.⁹⁷ Information on the network structure, including duct and dark fibre capacities, still has to be provided.

Bitstream access

Until very recently there was no regulated bitstream access wholesale service available in Germany. DTAG has offered its competitors particular wholesale services in the past which from DTAG's perspective have been viewed as services at least similar to bitstream access. However, these wholesale services did not give competitors freedom to develop their own products and services and to adjust quality of service.

In 2006, BNetzA obliged DTAG to offer both ATM and IP based bitstream access. Standard offer negotiations on IP bitstream access closed early 2008. The German IP bitstream product is designed such that DTAG leaves a DSL access line to a competitor and transports the data stream originated by/terminated to this access line via its concentrator network to the respective broadband point of presence where the traffic stream is exchanged. Recently (May 13, 2008), BNetzA made a decision regarding the prices of IP bitstream access. By virtue of this price decision IP bitstream access is available for the first time in Germany and should (in theory) give competitors that have not deployed own infrastructure up to the MDF some flexibility for providing services with own features. The bitstream access obligation does for the time being not cover VDSL.

Additional options for bitstream access (e.g. bitstream at the MDF or the street cabinet) are currently discussed controversially in Germany. Infrastructure-based competitors argue that the option of bitstream access at the street cabinet is not efficient from a technical and economic perspective.

⁹⁶ See press release BREKO, June 1 2007 "BREKO fordert klare Aussage zum VDSL-Zugang"; press release VATM, June 4, 2007 "Bundesnetzagentur will Wettbewerbern eingeschränkten Zugang zum Glasfaser-Netz gewähren".

⁹⁷ See BNetzA press release January 23, 2008 "Cologne court confirms Federal Network Agency's VDSL decision in summary proceeding", Administrative Court Cologne Decision 21 K 2701/07 of 23.04.2008. DTAG has appealed against the decision to the Federal Administrative Court.

5.1.2 Model results

5.1.2.1 Country specific assumptions

For Germany we assume a total potential broadband customer base of 42.8 mill. customers, 38.9 mill. of which are residential customers and 3.9 mill. of which are business users. Remember that these numbers include those potential (fixed-line) broadband customers which are currently using cable modem services for internet access, those which are using only mobile services for their communications needs, and those (few households) which do not use electronic communication services at all. The potential customer base also includes those areas where there is no DSL or cable coverage at the moment.

For very specific historic communications policy reasons in Germany which should not be detailed here, cable operators have not been as successful in offering double or triple play services as they could be given their broad network coverage. The broadband market share of cable currently amounts to 6% with a growing tendency. In five years time cable could have doubled this market share. Compared to an EU average of 24% the number of mobile-only households in Germany is much lower and amounts to 11%.⁹⁸ The number of households not using electronic communications at all, is relatively small, but amounts to another 2%.⁹⁹ Altogether it is unlikely that fixed-line operators can reach 100% of the total broadband customer base. Realistically, not more than 80% of the potential customer base of 42.8 mill. seems to be addressable for the fixed-line operators to provide NGA services.

According to our density criteria¹⁰⁰ only 13.7% of the (potential) customers live in high density urban areas, another 23.7% are located in suburban areas and the major part of customers live in less dense rural areas.

⁹⁸ EU Commission: eCommunications household survey: The results of a special Eurobarometer survey, No. 293, June 2008.

⁹⁹ EU Commission: eCommunications household survey: The results of a special Eurobarometer survey, No. 293, June 2008.

¹⁰⁰ See the definition in section 4.3.

Table 8: Spatial distribution of the customer base in Germany

Germany			
Cluster Type	Customer Base		
	in mill.	in %	accumulated %
Dense Urban	0.12	0.3	0.3
Urban	0.9	2.1	2.4
Less Urban	4.9	11.3	13.7
Dense Suburban	2	4.8	18.4
Suburban	2.85	6.6	25.1
Less Suburban	5.25	12.3	37.4
Dense Rural	14.6	34.1	71.5
Rural	12.2	28.5	100.0
Total	42.83	100.0	

Source: WIK-C

The structural parameter values in Table 9 show that the German PSTN network has a relatively decentralised structure. On average, 47 street cabinets are connected to one MDF. Given this structure and the distribution of population the average sub-loop length only amounts to 300 m, which makes VDSL an attractive NGA technology to roll out.

Table 9: Structural parameters of the PSTN network in Germany

Structural parameter	Value
Total number of main distribution frames	7,900
Total number of street cabinets	~ 374,000
Average sub-loop length (in metres)	~ 300

Source: WIK-C

The average revenues per subscriber which we use in the model are driven by service prices and the distribution of customers for the various services. The broadband penetration rate has reached in the meantime more than 50% of all households. For the model we assume a further growth in penetration to around 80%. Around 20% of all customers are expected only to subscribe to a single play telephony service. IPTV still is in its infancy in Germany. Currently less than 1% of the TV households receive TV via DSL. For calculating the model revenues we have assumed a significant increase of IPTV to 13.5% of the potential customer base. Compared to several market surveys we regard this number as an optimistic assumption. A triple play service price (including an internet and telephony flat rate) of 45 € per month reflects the current price level of alternative operators. The incumbent prices are a bit higher; the most aggressive triple play services of cable operators are offered for less than 30 € per month. A business revenue of 50 € may be regarded as low. It has, however, to be considered, that we

only model the basic communications triple play services. Any other service only contributes to the ARPUs via its net revenues.¹⁰¹

Table 10: Assumptions on average revenues per subscriber in Germany

Type of subscriber	Average revenue per subscriber (in €)	Share of the total customer base (in %)
Single Play	20.0	18.2
Double Play	35.0	59.1
Triple Play	45.0	13.6
Business	50.0	9.1
Total	35.0	100.0

Source: WIK-C

For all scenarios we assume a WACC of 10%. This number compares to a WACC of around 8% which the Federal Network Agency uses to calculate ex ante regulated wholesale services of DTAG and a cost of capital for investment projects of alternative operators which goes up to 15%.

5.1.2.2 Model scenario results

Our model calculates results for each particular cluster of the customer base and for each NGA technology. In section 4.3.1 we have defined the scenarios we are considering for each country. Because the results are presented always in the same way, we will interpret them in more detail in the first case presented, i.e. the German case.

¹⁰¹ Gross revenues minus service-specific costs.

Figure 29: Model results for the VDSL roll-out of the incumbent in Germany

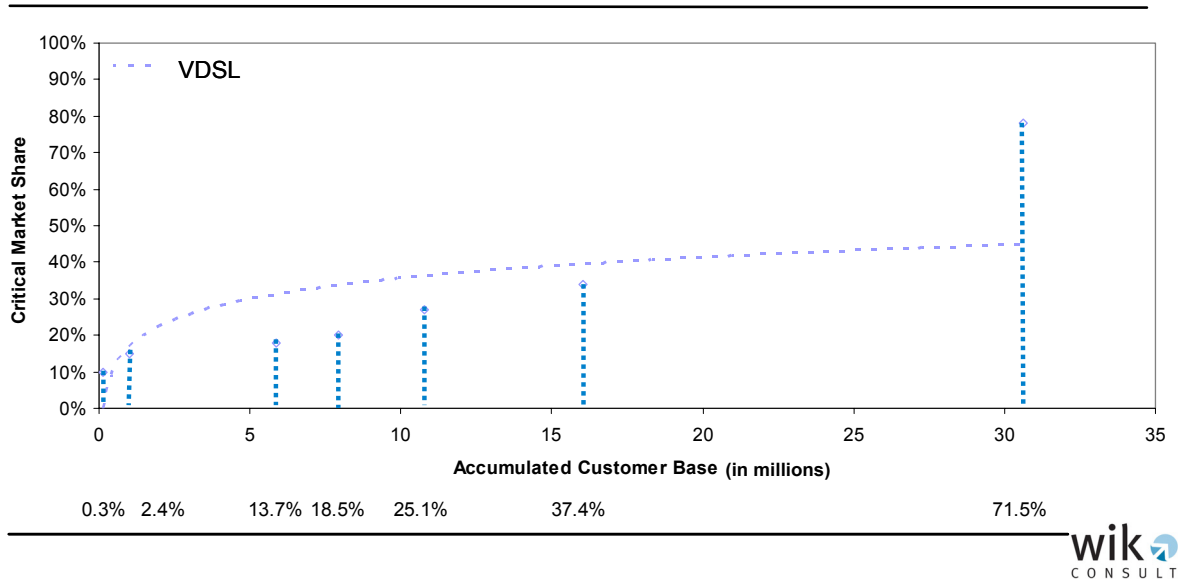

Source: WIK-C

The model results of the incumbent's VDSL roll-out are presented in Figure 29. Deutsche Telekom could (theoretically) roll out VDSL up to the dense rural cluster or for up to 71.5% of the potential customer base or population. However, for the dense rural cluster Deutsche Telekom would need a market share of at least 77% for a profitable roll-out in that cluster. This critical market share is defined by the point where the cost curve cuts the revenue line as shown in Figure 30. In reality this roll-out reach only represents a theoretical value. Because of the market factors mentioned in the previous section, only a maximum of about 80% of the potential customer base is addressable for fixed-line operators (due to potential presence of cable, mobile-only households, and households that do not use telecommunications services at all).

Figure 30: VDSL cost curve of the incumbent in the dense rural cluster in Germany

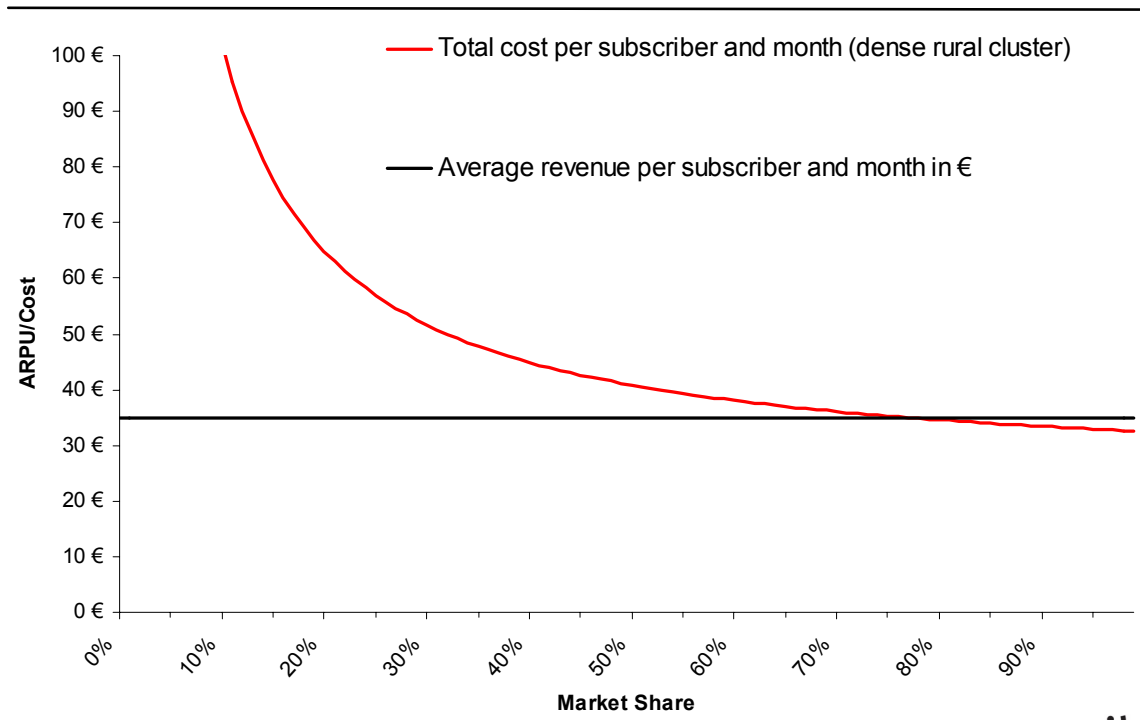

Source: WIK-C

Therefore the incumbent would have to acquire any relevant customer as a subscriber to its services in that cluster. To offer VDSL profitably in the other clusters the incumbent would need a significantly lower market share. In the less suburban cluster a critical market share of only 34% is required for the incumbent to reach profitability. The critical market shares decrease with the density of subscriber distribution.

The dotted line in Figure 29 represents a logarithmic approximation of the individual critical market shares of the clusters, for which the model generates results. The curve gives an indication of results for covering areas which are different to our clusters.

Table 11 presents VDSL roll-out results for Germany for all scenarios defined in section 4.3. A stand-alone operator which acts as a first mover and can therefore realise the full revenue potential of NGA has to realise about 50% more in market share to reach profitability compared to the incumbent in each cluster. A stand-alone operator, which does not have access to any wholesale products except copper SLU, can theoretically roll out its VDSL network up to the 37.4% of the potential customer base. This operator would, however, need a 48% market share for profitability in the less suburban cluster compared to only 34% of the incumbent. This difference is mainly explained by the incumbent’s better use of infrastructure and its ability to sell MDF sites and save investments due to the extra income.

Table 11: Critical market shares under different market and regulatory scenarios for rolling-out VDSL in Germany¹⁰²

VDSL - DE										
Cases	First Mover Cases			Second Mover Cases						
	Accumulated Customer Base	Stand Alone	Incumbent	80% Infrastructure Sharing	80% Dark Fibre and Infrastructure Sharing	80% Dark Fibre and Infrastructure Sharing	20% Infrastructure Sharing	20% Dark Fibre and Infrastructure Sharing	20% Dark Fibre and Infrastructure Sharing	20% Dark Fibre
Dense Urban	0.3%	15%	10%	17%	11%	11%	21%	20%	20%	20%
Urban	2.4%	22%	15%	23%	14%	13%	30%	28%	28%	28%
Less Urban	13.7%	26%	18%	31%	17%	17%	37%	34%	34%	34%
Dense Suburban	18.5%	30%	20%	35%	21%	19%	42%	39%	39%	39%
Suburban	25.1%	39%	27%	46%	26%	24%	55%	51%	50%	50%
Less Suburban	37.4%	48%	34%	65%	34%	29%	71%	63%	62%	62%
Dense Rural	71.5%	98%	78%	n.v.	64%	58%	n.v.	n.v.	n.v.	n.v.
Rural	100.0%	n.v.	n.v.	n.v.	n.v.	n.v.	n.v.	n.v.	n.v.	n.v.

n.v. = Not viable
Source: WIK-C

¹⁰² The percentage values in the table indicate the critical market shares for profitability, i.e. the revenue – cost break even.

In the real world it is more realistic to compare the second mover cases with the incumbent case. The second mover aspect is modelled by reducing ARPUs by 10%. The second mover has to offer its products at lower prices than the incumbent to ensure that customers will migrate to the second mover. The second mover cases differ by the degree and the type of access to wholesale services alternative operators can make use of. In the more "optimistic" regulatory scenarios alternative operators can cover 80% of their infrastructure needs by access to ducts or aerial cable deployment and can share the street cabinets with the incumbent. Second movers can profitably roll out their VDSL networks significantly less than the incumbent. (Theoretical) replicability of the incumbent's roll-out even under optimistic regulatory assumptions is possible up to the dense suburban cluster or for up to 18.5% of the customers. If one assumes a market share of 50% for the incumbent, which represents its current broadband retail market share, there is replicability for two operators only for 2.4% of customers and 13.7% in some scenarios. Access to dark fibre in the backhaul from the street cabinet increases replicability more than just duct access. The results also show that limited duct and dark fibre access limits replicability to the dense and urban areas or to only 2.4% of customers.

The market potential for FTTH on the basis of a PON architecture is more limited than the NGA roll-out of VDSL as Table 12 (compared to Table 11) shows. The incumbent (or another first mover operator) could profitably roll out up to the suburban cluster or up to 25.1% of the customer base. The required market share exhibits nearly no replicability. Even if a second mover could make use of 80% of empty duct at cost-based rates it would need a 35% critical market share in the most attractive (small) cluster. These results obviously show that the basic (passive) infrastructure of a FTTH roll-out is de facto not replicable in Germany and, thus, it is fair to state that the market tends to a natural monopoly market structure in the FTTH case.

Table 12: Critical market shares under different market and regulatory scenarios for rolling-out FTTH-PON in Germany¹⁰³

PON - DE										
Cases	First Mover Cases		Second Mover Cases							
	Accumulated Customer Base	Stand Alone	Incumbent	80% Infrastructure Sharing	20% Infrastructure Sharing	SLU + 80% Dark Fibre and Infrastructure Sharing	SLU + 80% Dark Fibre and Infrastructure Sharing	SLU + 80% Dark Fibre and Infrastructure Sharing	SLU + 20% Dark Fibre and Infrastructure Sharing	SLU + 20% Dark Fibre and Infrastructure Sharing
Dense Urban	0.3%	33%	30%	35%	38%	8%	8%	8%	20%	20%
Urban	2.4%	48%	44%	50%	55%	11%	11%	11%	30%	30%
Less Urban	13.7%	65%	60%	65%	73%	12%	12%	12%	33%	33%
Dense Suburban	18.5%	69%	63%	69%	78%	17%	17%	17%	38%	38%
Suburban	25.1%	83%	77%	83%	94%	22%	22%	21%	50%	49%
Less Suburban	37.4%	n.v.	n.v.	n.v.	n.v.	36%	36%	27%	66%	61%
Dense Rural	71.5%	n.v.	n.v.	n.v.	n.v.	61%	61%	81%	n.v.	n.v.
Rural	100.0%	n.v.	n.v.	n.v.	n.v.	n.v.	n.v.	n.v.	n.v.	n.v.

n.v. = Not viable
Source: WIK-C

¹⁰³ The percentage values in the table indicate the critical market shares for profitability, i.e. the revenue – cost break even.

Only fibre sub-loop unbundling at an access point similar to the street cabinets of the existing copper access network generates relevant degrees of replicability. In the relevant clusters critical market shares of 10 to 20% are needed for profitability of alternative operators. If there is only a low level of infrastructure sharing in the feeder and backhaul segments assumed, these critical market shares double. These critical market shares support replicability of FTTH-PON for one and, under certain scenarios, even for two competitors in clusters wherever a first mover rolls out a PON architecture.

As Table 13 shows, the roll-out of a P2P FTTH-architecture is realistically only viable for 13.7% of the customer base in Germany. Even under far reaching infrastructure sharing conditions there is de facto no economic possibility for replicating infrastructure and therefore for competition at the level of passive network infrastructure. Competition in a P2P architecture can only be materialised through unbundled access to the fibres of the incumbent or any other first mover at the (new) metro core location. This type of access allows competition wherever a first mover rolls out a P2P infrastructure at relatively low market shares (less than 10 %).

Table 13: Critical market shares under different market and regulatory scenarios for rolling out FTTH-P2P in Germany¹⁰⁴

P2P - DE					
Cases		First Mover Cases		Second Mover Cases	
Cluster	Accumulated Customer Base	Stand Alone	Incumbent	80%	20%
				Infrastructure Sharing	Infrastructure Sharing
Dense Urban	0.3%	36%	33%	60%	48%
Urban	2.4%	54%	49%	81%	69%
Less Urban	13.7%	74%	68%	n.v.	94%
Dense Suburban	18.5%	82%	75%	n.v.	n.v.
Suburban	25.1%	n.v.	93%	n.v.	n.v.
Less Suburban	37.4%	n.v.	n.v.	n.v.	n.v.
Dense Rural	71.5%	n.v.	n.v.	n.v.	n.v.
Rural	100.0%	n.v.	n.v.	n.v.	n.v.

n.v. = Not viable

Source: WIK-C

¹⁰⁴ The percentage values in the table indicate the critical market shares for profitability, i.e. the revenue – cost break even.

5.1.2.3 Summary of results

Comparing Figure 31 and Figure 32 below describes the roll-out conditions for the various NGA technologies. Figure 31 represents the economic roll-out conditions for the incumbent. Figure 32 represents the (unrealistic) optimistic regulatory infrastructure sharing scenario for an alternative operator. The figures generate the main results for Germany:

- (1) Rolling-out VDSL is profitable and attractive to serve a major part of customers in Germany for the incumbent.
- (2) The roll-out conditions for FTTH are less favourable but still economically relevant.
- (3) Second mover alternative operators face less attractive market and cost conditions even under our optimistic regulatory and sharing modelling assumptions.

Figure 31: NGA roll-out opportunities of the incumbent by technology in Germany

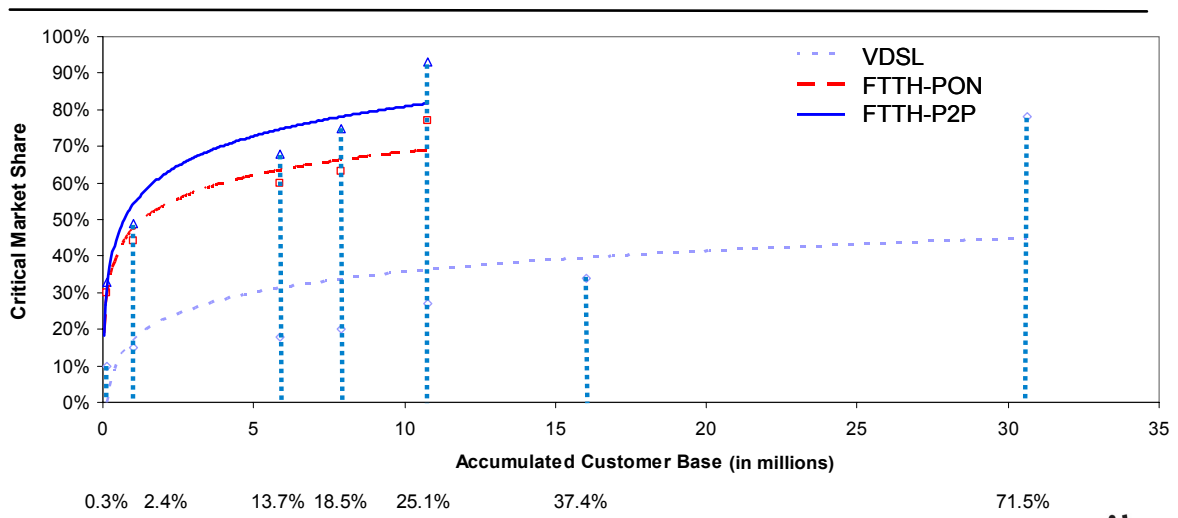

Source: WIK-C

Figure 32: NGA roll-out opportunities of an alternative operator in case of 80% infrastructure sharing in Germany

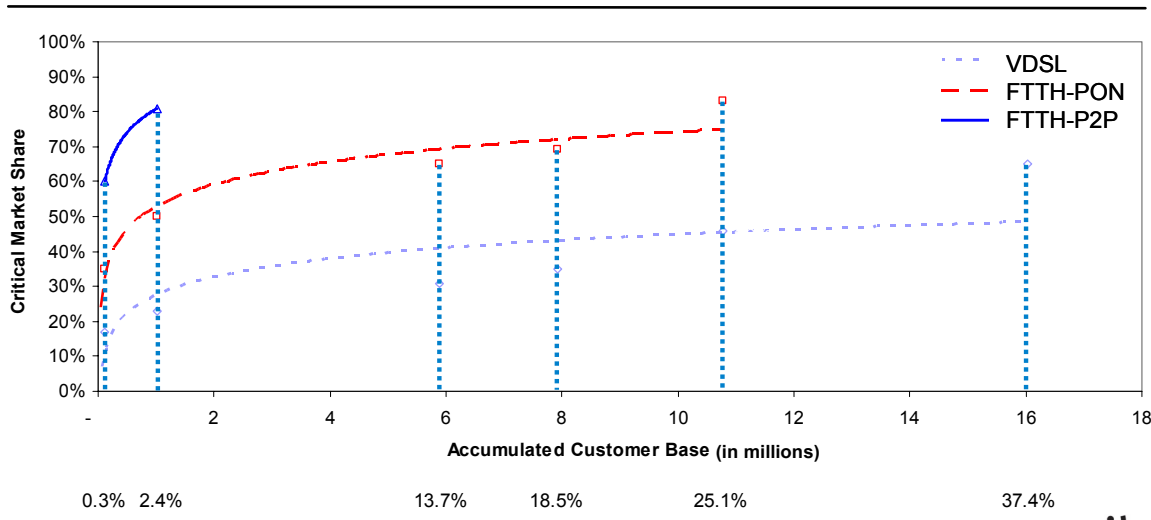

Source: WIK-C

- (4) Duct and dark fibre access increase the degree of replicability and potential competition to some extent; in any case infrastructure sharing and access is a necessary condition for competition.
- (5) In case of FTTH there is nearly no economic viability of infrastructure duplication in Germany, even with duct and dark fibre access. Only fibre SLU in case of PON and fibre LLU in case of P2P generate replicability and competition similar to unbundling today.

Only in case of fibre LLU and SLU there is replicability for more than one operator. In nearly all other scenarios and clusters there is no replicability, or if at all, only for one single second mover alternative operator.

5.1.2.4 ARPU sensitivities

In order to analyse how the model reacts on different ARPU assumptions we have chosen the German case because in this country the ARPU input values are in the medium range of the countries considered, and we varied the ARPU by $\pm 10\%$ ¹⁰⁵ in the stand-alone cases of the three architectural approaches.

¹⁰⁵ Compared with the values in Table 10 above this ARPU change might be caused by an increase/decrease of all revenue values by 10% or by a change of the ARPU for the triple play service alone or by a change of the shares of the various types of services.

Table 14: ARPU \pm 10% sensitivities for the VDSL stand-alone case, effects on critical market shares in Germany

VDSL - DE				
Cases		First Mover Cases		
Cluster	Accumulated Customer Base	Stand Alone*) Base Scenario	Stand Alone ARPU +10%*)	Stand Alone ARPU -10%*)
Dense Urban	0.3%	15%	11% (-27%)	22% (+47%)
Urban	2.4%	22%	16% (-27%)	32% (+45%)
Less Urban	13.7%	26%	20% (-23%)	38% (+46%)
Dense Suburban	18.5%	30%	22% (-27%)	44% (+47%)
Suburban	25.1%	39%	29% (-26%)	57% (+46%)
Less Suburban	37.4%	48%	36% (-25%)	71% (+48%)
Dense Rural	71.5%	98%	74% (-24%)	n.v.
Rural	100.0%	n.v.	n.v.	n.v.

n.v. = Not viable

*) In the base scenario the default ARPU of 35.0 € is used. In the two sensitivities the calculation is based on an ARPU of either 38.5 € or 31.5 €. The value in brackets is the change of the break-even market share of the sensitivity relative to the one of the base scenario (in %).

Source: WIK-C

In a VDSL environment and with an ARPU increase of ~10% the critical market share needed is about 25% less than in the base scenario. With an ARPU decrease of 10% the critical market share would increase by approximately 47% or from 15% to 22%. As one could already expect from the cost curve in Figure 30 the model reacts with relatively strong changes in the critical market share when moving the ARPU horizontal line up or down by 10%.

Since VDSL is a SLU business where the distribution network segment is installed according to the customer growth, the critical market shares in total are lower than in the FTTH stand-alone cases (without SLU) and even minor absolute changes in the ARPU result in a relatively higher percentage of change of the critical market share.

Figure 33: ARPU \pm 10% sensitivities for the VDSL stand-alone case, effects on critical market shares in Germany

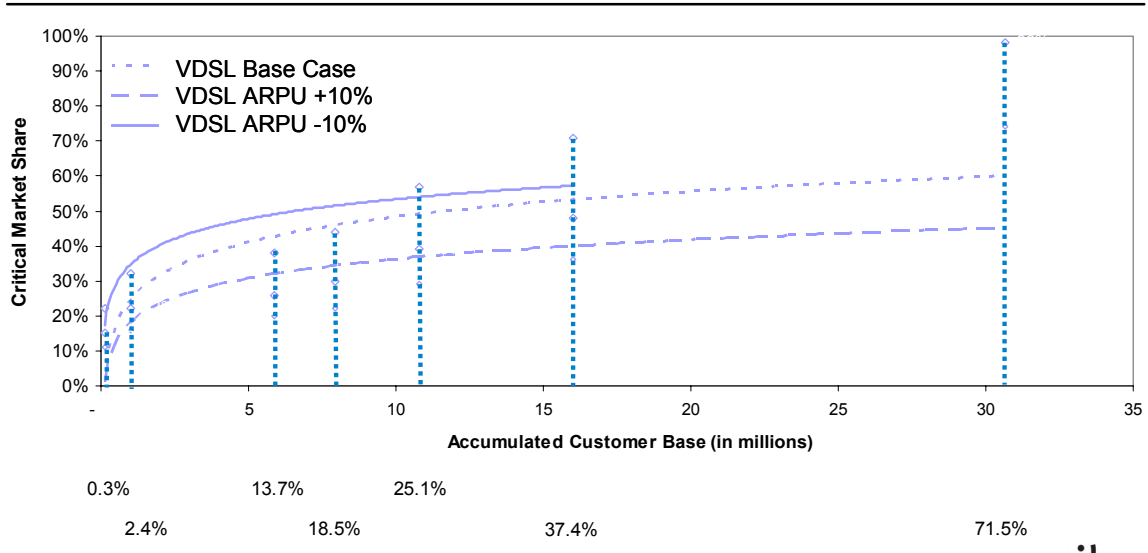

Source: WIK-C

Results for varying the ARPU in the PON stand-alone case are shown in Table 15 and Figure 34.

Table 15: ARPU \pm 10% sensitivities for the PON stand-alone case, effects on critical market shares¹⁰⁶ in Germany

PON - DE				
Cases		First Mover Cases		
Cluster	Accumulated Customer Base	Stand Alone*) Base Scenario	Stand Alone ARPU +10%*)	Stand Alone ARPU -10%*)
Dense Urban	0.3%	33%	29% (-12%)	39% (+18%)
Urban	2.4%	48%	42% (-13%)	57% (+19%)
Less Urban	13.7%	65%	56% (-14%)	76% (+17%)
Dense Suburban	18.5%	69%	60% (-13%)	81% (+17%)
Suburban	25.1%	83%	72% (-13%)	98% (+18%)
Less Suburban	37.4%	n.v.	100%	n.v.
Dense Rural	71.5%	n.v.	n.v.	n.v.
Rural	100.0%	n.v.	n.v.	n.v.

n.v. = Not viable

*) In the base scenario the default ARPU of 35.0 € is used. In the two sensitivities the calculation is based on an ARPU of either 38.5 € or 31.5 €. The value in brackets is the change of the break-even market share of the sensitivity relative to the one of the base scenario (in %).

Source: WIK-C

With an ARPU increase of ~10% the critical market share needed in the PON case is about 13% less than in the base scenario. With an ARPU decrease by 10% the critical market share would increase by approximately by 18% or from 15% to 22%. Thus the relative reaction of the critical market share is less strong.

¹⁰⁶ The percentage values in the table indicate the critical market shares for profitability, i.e. the revenue – cost break even.

Figure 34: ARPU \pm 10% sensitivities for the PON stand-alone case, effects on critical market shares in Germany

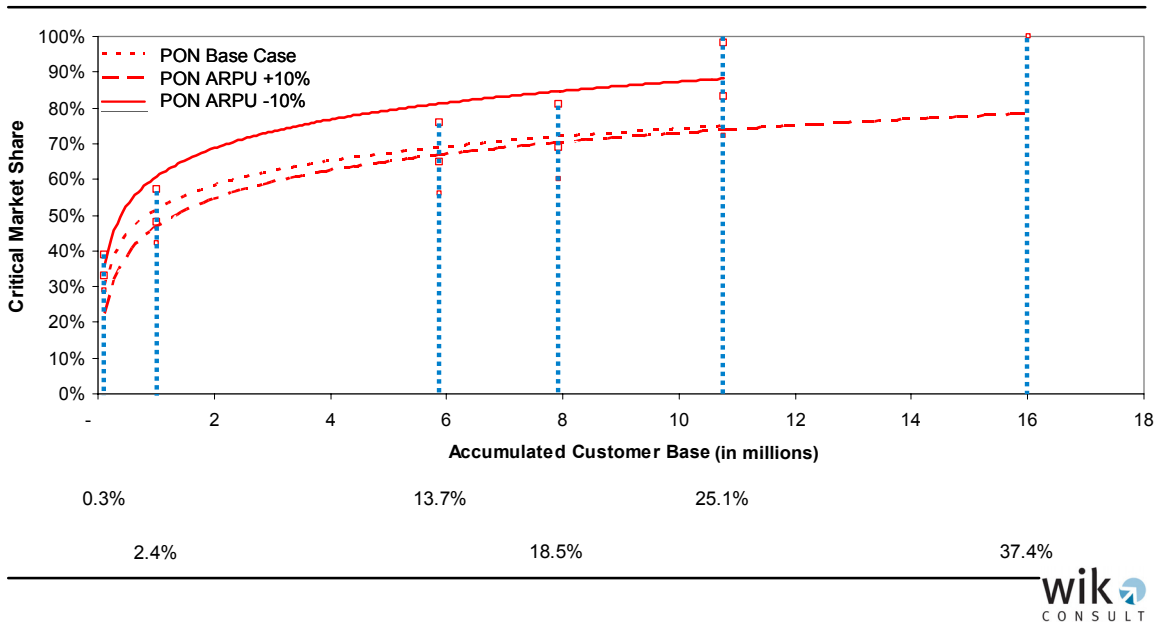

Source: WIK-C

The results of an ARPU variation of \pm 10% in the P2P stand-alone case are summarized in Table 16 and Figure 35. Increasing the ARPU by 10% decreases the critical market share needed by 16%; decreasing the ARPU by 10% increases the critical market share by 20% relatively or from 59% to 71%, and the suburban cluster, which had been at the edge of viability, now is definitively not viable at all.

Thus the model reactions in terms of the critical market share are even stronger than the changes of the ARPU itself.

Table 16: ARPU \pm 10% sensitivities for the P2P stand-alone case, effects on critical market shares¹⁰⁷ in Germany

P2P - DE				
Cases		First Mover Cases		
Cluster	Accumulated Customer Base	Stand Alone*) Base Scenario	Stand Alone ARPU +10%*)	Stand Alone ARPU -10%*)
Dense Urban	0.3%	36%	31% (-14%)	44% (+22%)
Urban	2.4%	54%	46% (-15%)	66% (+22%)
Less Urban	13.7%	74%	63% (-15%)	90% (+22%)
Dense Suburban	18.5%	82%	70% (-15%)	100% (+22%)
Suburban	25.1%	n.v.	86%	n.v.
Less Suburban	37.4%	n.v.	n.v.	n.v.
Dense Rural	71.5%	n.v.	n.v.	n.v.
Rural	100.0%	n.v.	n.v.	n.v.

n.v. = Not viable

*) In the base scenario the default ARPU of 35.0 € is used. In the two sensitivities the calculation is based on an ARPU of either 38.5 € or 31.5 €. The value in brackets is the change of the break-even market share of the sensitivity relative to the one of the base scenario (in %).

Source: WIK-C

¹⁰⁷ The percentage values in the table indicate the critical market shares for profitability, i.e. the revenue – cost break even.

Figure 35: ARPU \pm 10% sensitivities for the P2P stand-alone case, effects on critical market shares in Germany

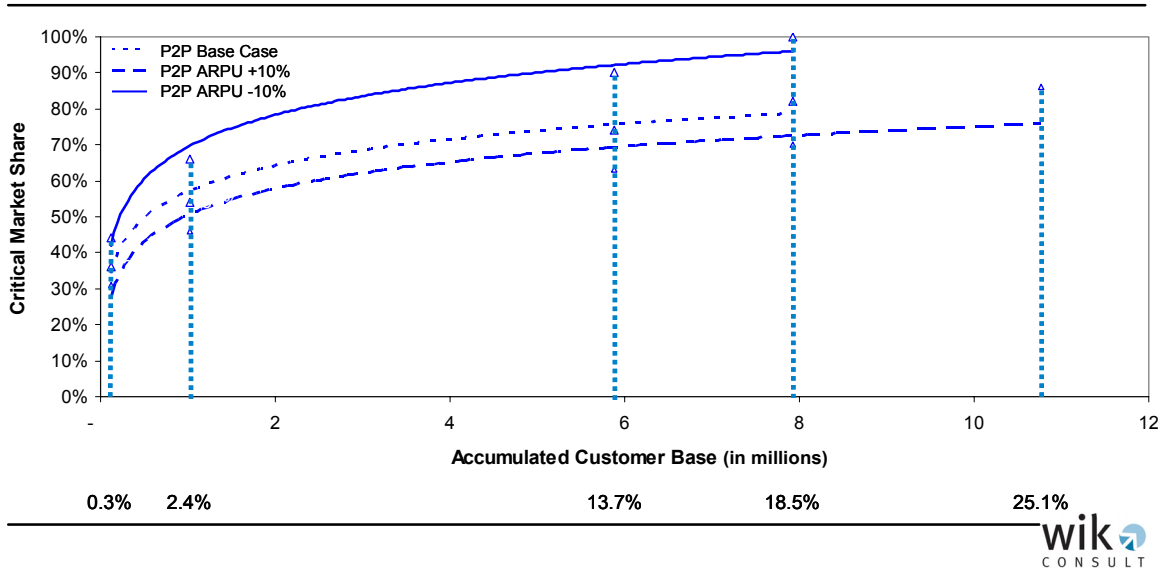

Source: WIK-C

5.2 France

5.2.1 Market developments and regulatory background

5.2.1.1 Strategic positioning of the main players in the broadband market

Background

The number of MDFs in France is about 13,500 (Source: ECTA Broadband Scorecard 2006) and the number of street cabinets is about 120,000 (Source: ARCEP). This yields a ratio of about 10 street cabinets/MDF. The average length of the sub-loop in France is about 750 m, see Hennes (2007).¹⁰⁸ According to ARCEP the theoretical coverage with ADSL2+ technology is not particularly high: 30 % of the population can obtain 15 Mbps, 55 % of the population 10 Mbps and 76 % of the population 5 Mbps.

According to recent information from ARCEP (Q2 2008) France has about 16.7 mill. broadband access lines. ADSL continues to be the overwhelmingly popular access

¹⁰⁸ It is worth stating that this figure mirrors a national average. In reality there are cases (taken account of as sub-clusters in our model) in France where the sub-loop length is significantly lower than 750 m.

technology, accounting for about 15.9 mill. access lines, with the remainder made up by cable, FTTx or satellite services.

According to the 13th Implementation Report FT has a market share of about 95 % regarding the copper based access lines and a market share of 47 % of all fixed broadband access lines (comprising DSL, cable, FTTB/H, satellite, powerline communications and other technologies).¹⁰⁹

The French government has published in November 2006 provisional plans to make broadband internet access available to all citizens in mainland France by 2012¹¹⁰. The Minister for the Digital Economy is expected to finalize the plans before the end of July 2008. Several major targets obviously have been formulated, including:

- fixed and mobile high speed access for all by 2012,
- the rollout of fibre-optic broadband to four million inhabitants by 2010,
- further development of very high-bandwidth mobile services.

Main market players regarding deployment of FTTx

The main operators deploying fibre in France are¹¹¹ :

- France Télécom,
- Iliad-Free,
- Neuf Cegetel,
- Numéricâble.

Moreover, there are a number of local and regional projects in France which focus on bringing fibre nearer to the end user. In these projects often jurisdictional institutions from French “Régions” or “Départements” play a prominent role. Major local authorities projects including FTTH are:

- Communauté Urbaine de Bordeaux,
- Conseil Général des Hauts de Seine,
- SIPPEREC,
- Gonfreville L’Orcher (Seine Maritime),
- CU du Grand Nancy,
- Syndicat Mixte Département de la Loire,

¹⁰⁹ As of mid 2008 this market share has increased to 49.5 %.

¹¹⁰ See <http://www.industrie.gouv.fr/portail/secteurs/planTHD.pdf>.

¹¹¹ The following information is based on ARCEP board member, Gauthey (2007).

- CA du Pays d’Aix
- Etc.

France Télécom

FT’s fibre deployment plan is carried out in three major phases.¹¹²

- FTTH pilot (2006): In the summer of 2006 France Télécom initiated FTTH tests in six arrondissements in Paris and cities of the department Hauts-de-Seine (“92”). Several thousand households were part of this test. FT has made fibre trials also in Marseille.
- Pre-rollout (2007-2008): For 2007 and 2008 FT has begun FTTH network deployment in Lille, Lyon, Marseille, Poitiers, the Ile de France area (including Paris), Bordeaux, Grenoble, Metz, Nantes, and Nice. By the end of 2008, FT plans to have 1 mill. homes passed and 150,000 – 200,000 homes connected (“active customers”). The cumulated Capex in this period is approximately 270 mill. Euro.
- Mass market rollout (2009-2012): Between 2009 and 2012 FT plans a massive nationwide FTTH rollout. The aim is to sign up to 2 mill. subscribers by 2012, thereby reducing costs per subscriber significantly from about 4,000 Euro in 2007 to about 1,000 Euro in the years 2010 – 2012, see next figure.

¹¹² See the presentation of FT’s CEO, Lombard (2007).

Figure 36: Costs per subscriber and planned total subscribership according to FT's roll-out plan for FTTB/H (2006 – 2012)

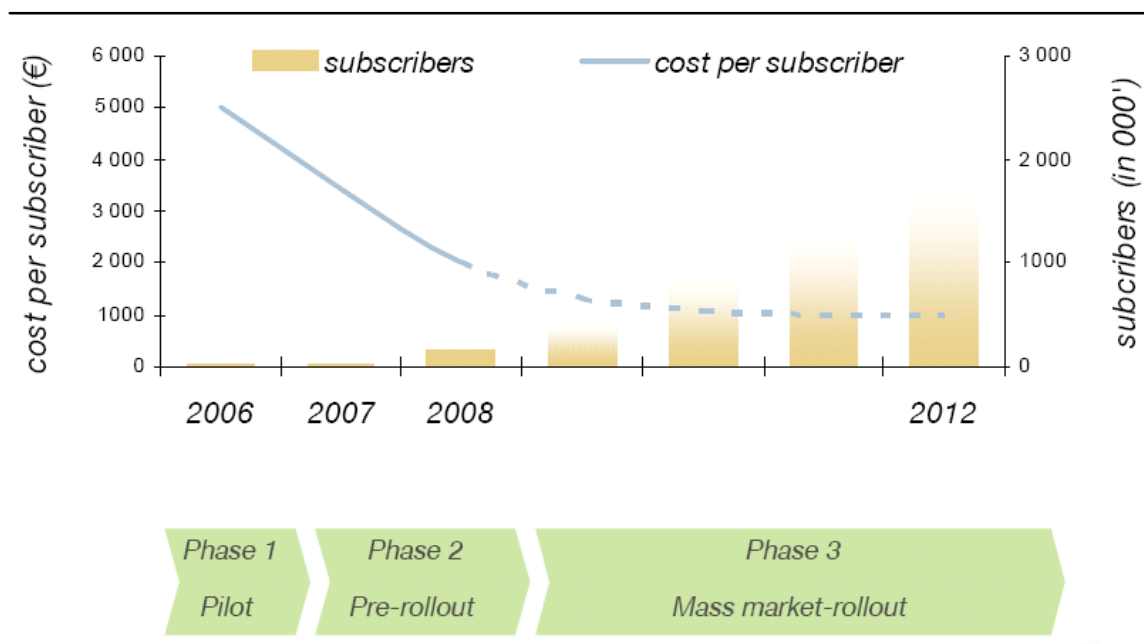

Source: Lombard (2007).

FT is implementing a G-PON architecture. The FTTH deployment of FT is based on the utilization of own ducts and aerial deployment (where possible).

Regarding the current regulatory policy discussions in France (see below) FT agrees in principle to make own ducts available to competitors. On 25 July 2008, the regulatory authority ARCEP mandated duct access (in the local access network) on France Telecom as part of the analysis of Market 4 (wholesale (physical) network access at a fixed location). Moreover, FT accepts ARCEP's recommendation that only one fibre network should be installed in a building and that the operator that is selected to install the building network should lease the building fibre to other operators on a non-discriminatory basis.¹¹³ However, as we will see below this is not at the very heart of the problem of establishing a level playing field for incumbent and competitors in the FTTB/H world, as the discussion about the location of the "mutualisation point" shows.

¹¹³ See Lightwave Europe (2008), January; http://lw.pennnet.com/display_article/321309/63/ARTCL/none/none/1/France-Telecom-plans-massive-FTTH-roll-out-in-2009

Free/Iliad

At the end of 2007 Free/Iliad had about 2.9 mill. ADSL subscribers (more than 3 mill. at the end of Q1 2008). The unbundling proportion is at 81.5 %. Free/Iliad had a ARPU of 36.50 Euro at the end of 2007.¹¹⁴

Free/Iliad aims at reaching four mill. homes passed by 2012 equalling a total population of 10 mill. The geographical focus is mainly Paris and its outskirts as well as particular areas in selected other French cities. Apart from downtown Paris, infrastructure deployment in 2007 has focused on Montpellier, Lyon and its outskirts, Valenciennes and suburban areas of Paris.

The roll-out plan of Free/Iliad specifies to cover 70 % of Paris in the second half of 2009. Currently outside of Paris, Free/Iliad has over 400,000 homes passed or under deployment for its fibre access service.

Free/Iliad is pursuing an Ethernet based Point-to-Point (E-FTTH) strategy with a specific architecture. An optical node (NRO) concentrates, on average, 30,000 optical lines. In addition to providing retail services, Free/Iliad also makes available a wholesale fibre loop offer. Thus, the NRO is configured to receive other operators' networks, by deploying their own equipment in the room (80-100 square meters on average) and renting the optical lines. In order to cover Paris in its entirety, Free would need to construct between 55 to 60 NROs. On the basis of the terminology defined in our model calculations, one could characterize the wholesale offer of Free/Iliad as fibre local loop unbundling.

Free/Iliad has relied for its deployments to date on the Paris sewer system, see below. Outside of Paris, and before the opening of FT ducts, they relied on civil engineering mainly by digging trenches to install fibre or to a lesser extent, as in the city of Valenciennes (North of France), by using an aerial solution along the walls of houses. In the city of Montpellier (south of France), Free is deploying a fibre optic network using facilities belonging to the city.

Free/Iliad intends its fibre to progressively replace its existing ADSL 2+ infrastructure in dense areas. Nevertheless, fibre areas will co-exist with ADSL 2+ areas during several years.

Free/Iliad will target locations based on the following criteria:

- Only those areas/neighbourhoods are targeted where it has at least a market share of 15 % (with respect to existing landlines (not only ADSL)). The selection of fibre areas is to a large extent based on the density of existing subscribers.

¹¹⁴ See Baillenx (2008).

Moreover, the cost of civil engineering alternatives (aerial, sewers, micro trenches) is taken into account.

- Fibre infrastructure will be deployed only in those areas where a Capex of around 1,500 Euro per existing subscriber is not exceeded. Free/Iliad estimate that a cost of 300-400 Euro is incurred per additional subscriber once the fibre is passing a building.

Free/Iliad is focusing on wiring the entire neighbourhood/areas with fibre from its NRO to each household.

For deployment of in-house infrastructure, Free is installing two fibres from each apartment: One goes directly to the NRO, one is dropped in the basement of each building, to allow connection by operators who roll out their own network until this point. The on-premise connection is free of charge for existing ADSL subscribers.

The next figure shows the inherent features of Free/Iliad's FTTH deployment plan over time:

- Lowering dependence on purchases of wholesale services from FT,
- Increasing the gross margin of its business activity.

Figure 37: Features of the strategic fibre deployment plan of Free/Iliad

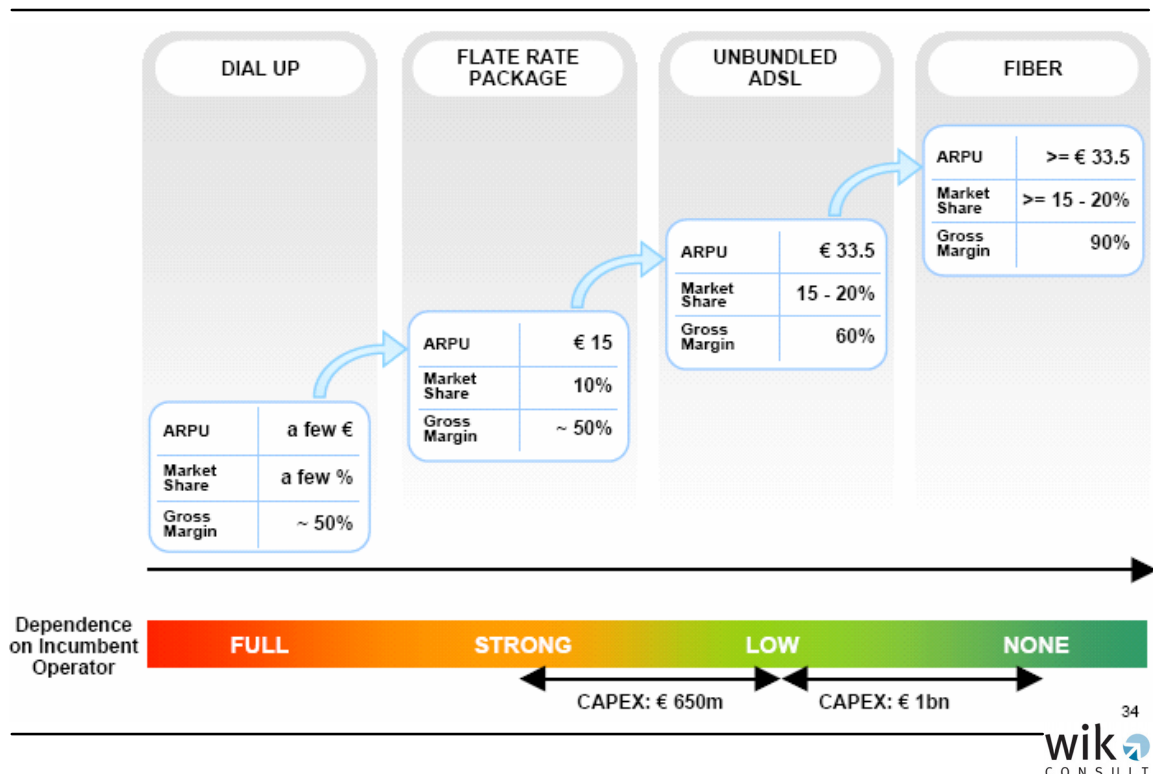

Source: Free/Iliad presentation 2006

Free/Iliad claim to have a 6-year cash pay back commitment based on the following assumptions:

- Migration of existing subscribers,
- ADSL-like ARPU of Euro 33.5 per month¹¹⁵,
- FTTH gross margin significantly higher than that of ADSL at Euro 30.

Free/Iliad's business model exhibits a significant sensitivity to market share and ARPU: they claim that at 25 % market share in year 3 the payback accelerates to around 4 years. A major factor for the viability of the business model of Free/Iliad is no further reliance on FT unbundling charges.

Neuf Cegetel

Neuf Cegetel was created by the merger of Neuf Telecom and the Vivendi subsidiary Cegetel in 2005. The two key shareholders of the merged Neuf Cegetel have been the Louis Dreyfus Group and the French mobile operator SFR (which is also backed by Vivendi). In April 2008, following approval by the relevant French competition authorities, SFR bought Louis Dreyfus' shares in Neuf Cegetel. SFR then launched an offer for all the remaining shares it does not already own. As of June 20, 2008 SFR owns 96.41 % of all shares of Neuf Cegetel.¹¹⁶ Neuf Cegetel reported revenues of 3,348 mill. Euros in 2007.

Neuf Cegetel operates its own national network infrastructure, comprising 49,000 kilometres of optical fibres. The company has access to about 1,700 MDFs giving (DSL based) access to about 70 % of the population. Neuf Cegetel has access to about 2.5 mill. unbundled local loops, equaling about 50 % of the total French ULL market. Neuf Cegetel's serves residential customers, corporate customers as well as other operators and Internet service providers.

In recent years, Neuf Cegetel has purchased several local operators with experience of offering very high speed broadband services and has started deployment of its FTTH network in Paris through different actions.

- In late 2006, Neuf Cegetel purchased Mediafibre, a regional operator in Pau, southwest France, with approximately 3,000 customers. This operator was responsible for the municipal FTTH project called "Pau Broadbandcity".
- In 2007 Neuf Cegetel acquired Erenis, a company focusing on FTTB, that has been laying fibre in Paris since 2003 and had acquired over 10,000 customers.

¹¹⁵ As mentioned earlier this ARPU has increased to about 36.50 Euro at the end of 2007.

¹¹⁶ See TeleGeography's CommsUpdate, June 20, 2008 "SFR increases Neuf Cegetel ownership to 96.41%".

- Neuf Cegetel has already initiated deployment to connect 400,000 homes in Paris and the surrounding region through FTTx. Early 2007, through its LDCollectivités subsidiary, Neuf Cegetel won the Opalys concession, the first public service delegation to develop a fibre-optic residential network in the Paris region. A total of thirteen municipalities will be served by this network. In addition, LDCollectivités is part of the consortium selected by the Hauts-de-Seine departmental authorities for the public service delegation to build the Hauts-de-Seine fibre optic broadband network.
- In February 2008, Neuf Cegetel was selected by OPAC (Paris), the social housing agency, to provide tenants with an adapted triple play service. Launched in September 2007, the aim of OPAC's program is to provide tenants with an affordable triple play service (broadband internet, telephone and television), close to the current cost of the shared antenna service.¹¹⁷ This service will gradually be rolled out starting in the second half of 2008, with DTT due to be fully operational by July 2009 and the internet and telephony services by December 2009. The fibre-optic infrastructure access network that Neuf Cegetel will deploy and operate for this purpose will be shared and open to all ISPs.

Recently, Neuf Cegetel has made its broadband deployment plans more concrete.¹¹⁸ The company wants to be able to offer in the next 5 to 8 years broadband internet access to 10 million (40 % of all French) households. CEO Esser, however, also has underlined that (the speed of) own infrastructure deployment depends very much on regulatory conditions, in particular with respect to the actual solution regarding the "mutualisation" (see below) of networks of different operators. He announced that Neuf Cegetel wishes to pass around 5 million homes before the end of 2012 by own infrastructure investments (provided there is access to ducts of France Télécom and suitable conditions regarding mutualisation). Neuf Cegetel intends to cover most of Paris before end of 2009. In order to be able to reach 10 million households, CEO Esser underlines the significance of sharing networks, which could in particular be built by public initiatives ("collectivités locales").

Numericable

Numericable is a company that was growing in the past six years through a series of acquisitions comprising e.g. the former independent companies France Télécom Câble,

¹¹⁷ The triple play service enables tenants to receive the 18 digital terrestrial television (DTT) channels compatible with high-definition television (Full HD), internet at a speed of 512 kbits/sec. and a telephone line with free and unlimited incoming calls, and toll-free outgoing calls to emergency numbers, as well as certain special numbers.

¹¹⁸ See interview with CEO Esser in Le Figaro, June 25, 2008; <http://www.lefigaro.fr/economie/2008/06/25/04001-20080625ARTFIG00604-sfr-le-reseau-doit-etre-ouvert-a-tous-les-concurrents.php>.

TDF Câble, NC Numericable, Noos SA and UPC France SA. Since August 2007 Numericable is the single brandname for all of these former independent networks. The Numericable networks comprise 99.6 % of all French cable networks.

Numericable's network extends to 9.5 mill. apartments located in more than 1,200 cities and villages in France, thus, reaching about 40 % of all French households. In 2007 Numericable's revenue was close to 1 bn. Euro.

In 2006 Numericable has started to overhaul completely its network by accessing all households with optical fibre. Numericable relies on DOCSIS 3.0 and a FTTB/coax infrastructure (fibre is deployed up to the building basements, coax inside wiring remains in use). The company is offering triple play services (100 Mbps Internet access download/5 Mbps upload, HDTV, more than 230 TV channels, VOD, telephony). Currently, about 2 mill. households have FTTB fibre access. Numericable claims on its web site that its network investment plans in total are close to 10 bn. Euro.

A company associated with Numericable recently was selected as the lead contractor for the THD92 (Réseau départemental à Très Haut Débit) project in Hauts-de-Seines (Département 92). Thus, the company associated with Numericable will be required to lease the fibre infrastructure established as part of this project to any third parties.

Wrap up

France will be exclusively relying on FTTB/H for the upgrade of broadband networks - no FTTC/VDSL ventures are observable. This is due to the very long sub-loops which prevent use of the higher bandwidths of VDSL technology compared with ADSL technology.

All market players in France deploying fibre infrastructure benefit at least in Paris from infrastructure conditions second to none in other parts of France and perhaps also throughout Europe. The city of Paris benefits from a network of sewage channels which are ubiquitous and larger than man-high. Moreover, they lead into each building. Thus, fibre deployment in Paris is comparatively easy by using this existing infrastructure.

In addition, the costs of fibre deployment have been substantially reduced by a decision of the city of Paris in 2006 which in effect lowered substantially the price of using the sewage channel infrastructure for fibre deployment. In Paris a price of 6.5 Euro/m p.a. is charged for „business local loop“ and „backhaul network“. The City of Paris originally aimed at charging this price also for fibre optic access lines for the consumer market. However, both market participants and ARCEP reached the conclusion that no business case would be viable on this basis. French operators then reached a compromise with the City of Paris on a 90 % price reduction (i.e. a price of 0.65 Euro/m p.a.) for the „final 400 meters“ of the local loop. Only lengths of routes greater than 400 m will be charged with 6.5 Euro/m p.a.. This is offered on a non-discriminatory

basis to all market participants. These prices reflecting the situation in 2006 are currently under negotiation again.

It is our understanding that phasing out of MDFs currently is not being discussed in France.

Market players in France pursue a geographically focused FTTB/H deployment strategy. This is based on targeting limited areas where the players enjoy high market share with relatively low per customer costs. First mover advantage is considered by investors to convey a substantial advantage and to weaken the business case for subsequent investors.

Sharing of infrastructure (e.g. by setting up an arrangement similar to an IRU where an operator finances part of the investment made by another operator in exchange for a right to access a proportion of households) has been considered by competitors as a vehicle to lower deployment costs and avoid inefficient duplication.

5.2.1.2 Regulation, *wholesale services*

Access to ducts

ARCEP conducted a consultation on access to ducts between July and September 2007.

Regarding this issue ARCEP is arguing that FT utilizes for its FTTB/H deployment its own infrastructure (inherited from monopoly times). This duct infrastructure is partly under-utilized and therefore it could be used for the deployment of FTTB/H networks by competitors. ARCEP underlines that competitors should have access to these infrastructures in order to establish fair competition in the high-speed broadband market. Hence, the objective of regulation should be to set appropriate incentives for investments in local loop infrastructure. A possible implication could be less asymmetric downstream regulation.

Recently (June 2007), Free/Iliad sued FT before the antitrust authority claiming anti-competitive behaviour, i.e. refusing to give its competitors access to its civil engineering infrastructures. In this regard, the Conseil de la Concurrence reached the following decision on 12 February, 2008¹¹⁹.

- FT's holding of civil engineering infrastructures is likely to give the company a particular responsibility, notably including not to distort the play of competition on the budding market for very high speed services, in keeping for itself the use of

¹¹⁹ See http://www.conseil-concurrence.fr/user/standard.php?id_rub=256&id_article=888.

the infrastructures and refusing its competitors to use them, or giving them a discriminatory access.

- FT started to deploy optical fibre in its civil-engineering infrastructures with the copper local loop, while postponing its response to competitors' request for having access to the same infrastructures.
- The Conseil decided to carry on with the investigation on the merits of the case.
- Nevertheless, the Conseil decided not to order interim measures, considering that there was no serious or immediate infringement to the sector.
- The Conseil noted that since October 2007 France Telecom had committed itself before ARCEP to elaborate an access offer to its ducts, which should normally lead to an operational offer in Summer 2008.

The Conseil notes that the first tests seem to globally satisfy alternative operators.

Tests of access to FT ducts have been started so far in a few cities, e.g. in Montrouge and Clichy (two cities next to Paris).

Access to ducts, i.e. in particular the determination of obligations imposed on FT, play a prominent role in the analysis of market 4 (wholesale (physical) network infrastructure access) and 5 (wholesale broadband access) by ARCEP. ARCEP adopted its decisions on these markets on 25 July 2008.

Regarding market 4¹²⁰ ARCEP defines the relevant market to include metallic loops/sub-loops (however, not Cable TV infrastructure), dark fibre (in the access network), and civil works infrastructure (in the access network). The market definition also explicitly comprises the civil infrastructure and fibre infrastructure of local authorities (within the local wired access network). ARCEP has decided that this market is national in scope, and that France Telecom has SMP on the wholesale market for access to these infrastructures.¹²¹

The existing obligations on FT for metallic local loop/sub-loop unbundling are broadly maintained and the existing FT fibre backhaul offer in the context of metallic loop unbundling is confirmed and hence becomes the subject of a firm regulatory obligation.

¹²⁰ See www.t-regs.com.

¹²¹ The ARCEP decision enlarges the current infrastructure access obligation on FT. The new obligation covers the infrastructure relevant to the local access network, including ducts and chambers used to connect both residential and business customers, a process for ensuring that construction occurs where there are capacity constraints (« *de-saturation* »), and procedures for access to information and updating of such information relating to civil infrastructure access. This access must be provided on non-discriminatory conditions compared to FT's self-supply and a reference offer for local infrastructure access must be published.

However, no remedies have been identified with regard to fibre infrastructure, i.e. fibre unbundling is not mandated.

Regarding market 5 ARCEP previously considered that all wholesale bitstream offers based on DSL (metallic twisted-pair loops/sub-loops), cable (coaxial) and fibre are substitutable and are part of a single national market (in particular independent from whether IP, ATM, or Ethernet technology is used). However, following comments from the EU Commission in its letter dated July 18, 2008, ARCEP excluded wholesale bitstream access provided over cable TV. Powerline, WiFi, and WiMax are also excluded from the market definition.

On market 5 FT is found to have SMP. ARCEP continued the previous bitstream obligation (slightly amended). Yet, no obligation of bitstream access over fibre access lines has been specified. The existing obligations on FT for wholesale broadband access at regional level over metallic local loop/sub-loops are broadly maintained and extended to include Ethernet bitstream where FT has installed DSLAMs capable of Ethernet. Yet, an explicit decision is made not to mandate multicast over Ethernet.

Bitstream over fibre is not mandated. It is neither viewed necessary nor proportionate, mainly due to the fact that fibre in the access network is not inherited from the monopoly period. Moreover, ARCEP points to the Law which specifies a symmetric obligation on all providers to grant access.

Access to buildings, sharing of in-house infrastructure, "mutualisation points"

ARCEP conducted a consultation focusing on the sharing of in-house infrastructure in an FTTB/H environment between July and September 2007.

In this context ARCEP has stated that it cannot be efficient that each fibre based operator deploys its own fibre strands and optical connectors in each building and each apartment, respectively. Thus, the interests of home owners are involved as well as potential renters of fibre. ARCEP favours the principle that end users have the chance to switch their broadband operator without the need to move from one location to another. Thus, ARCEP sees the need for infrastructure sharing. In this respect, one has to take account of technical, financial and legal issues.

Market participants emphasise that in practice access to buildings in France is not an easy task and authorisations from social housing companies or landlords are difficult to obtain. This is even true of Paris where fibre is arriving directly in the cellars of the house from the sewers, see above.

On 23 July 2008, the French Parliament has adopted the 'Loi de modernisation de l'économie',¹²² a wide-ranging law, articles 109 to 120 of which address the telecommunications sector. Art. 109 VI imposes an obligation, applicable to all persons or entities (including network operators) that have established a fibre-optic line that enables the provision of very high-bandwidth electronic communications to an end-user on a private property, to meet reasonable requests for access to that fibre-optic line, emanating from operators wishing to provide electronic communications services to that end-user. The wording of the obligation is of particular interest, because it does not specify the physical location of the access point, but it indicates that the access point is to be located outside the private property (unless ARCEP approves the access point being inside) and must enable the effective connection of third-party operators, under conditions that are reasonable from an economic, technical and accessibility perspective. Nothing is stated about fees that will be applied for these fibre access connections (but it is clear that fees will apply). Art. 109 VI also modifies existing legislation to ensure that disagreements about conditions for such fibre access are subject to ARCEP's dispute-resolution powers under the existing Art. L. 36-8. Moreover, it enhances the existing Art. L. 36-6 in a manner which enables ARCEP to make an ex-ante determination of the technical and financial conditions of the new symmetric fibre access obligation.

In this context and against the backdrop of a discussion process that ARCEP has initiated recently with operators and house owners alike, ARCEP has opened a public consultation on May 22, 2008 which runs until June 27, 2008, see ARCEP (2008). The focus of this consultation is on the deployment of the terminal part of optical networks ("point de mutualisation"), and suggests that ARCEP agrees that being the first mover conveys an advantage and that access to fibre inside the building may not alone be sufficient to ensure contestability.

ARCEP aims at establishing a principle to be applied to all operators under which the first operator who has equipped a building with fibre grants access to its network to other operators. The underlying assertion is that it does not seem viable for several operators to install fibre inside the same building, or to quote ARCEP: "Sharing the terminal part of fibre networks is indispensable to the competitive functioning of the market". ARCEP hopes that the means of sharing and agreement practises will be defined as soon as possible¹²³.

The consultation document actually has two parts. The first part concentrates on the role and responsibilities of the "building operator" (opérateur d'immeuble). In the document the term "opérateur d'immeuble" denotes the single entity that is authorised to install or to exploit optical fibre in a building. The second part of the consultation

¹²² The Law entered into force on August 6, 2008.

¹²³ See

[http://www.arcep.fr/index.php?id=8455&L=1&tx_gspublication_pi1\[typo\]=8&tx_gspublication_pi1\[uidDocument\]=607&cHash=3e85a53dc7](http://www.arcep.fr/index.php?id=8455&L=1&tx_gspublication_pi1[typo]=8&tx_gspublication_pi1[uidDocument]=607&cHash=3e85a53dc7).

focuses on the interrelationship between operators and owners of a building (and/or entities administering a building). In this context a specific focus is on the location of the “point de mutualisation” (within a building, outside a building), where the second, third, etc. operator can access the network of the early mover, who has deployed fibre at first. ARCEP is expected to decide on the “point de mutualisation” issue before the end of 2008.

Following the roll-out plan of France Telecom access to fibre would only be technically possible in the basement of apartment buildings (due to the location of the GPON splitters). It is, however, obvious that the basement of a building gives access to only a relatively small number of households. It is therefore plausible to state that this in all likelihood will not be the basis for a viable business case for other operators. Market participants from France are arguing that a shared access point will be economically viable only if it gives access to more than 500 households. They therefore favour a concentration point much higher up in the network, i.e. nearer to their own existing networks. In our model we refer to this case as fibre sub-loop unbundling. The new French 'Loi de modernisation de l'économie', adopted on 23 July 2008 (see above), takes up these expectations and requirements.

5.2.2 Model results

5.2.2.1 Country specific assumptions

In France the total potential customer base amounts to 33.9 million customers. 30.8 mill. of which are residential customers and 3.1 mill. are business users. These numbers include broadband customers which will use cable modem services for internet access, mobile-only households and those which do not use electronic communications services at all.

So far cable does not play a strong role in the French broadband market. Only 5% of all broadband customers are currently served by cable operators. Given the consolidation of the French cable industry under the roof of Numericable and the far reaching network upgrading program underway, we expect, however, cable to become a more relevant player in the broadband market in the future which will increase its market share. 16% of all households in France only use mobile devices for their communications needs.¹²⁴ These aspects lead to the conclusion that fixed-line operators might not be able to address more than 80% of the total broadband customer base.¹²⁵

¹²⁴ See EU Commission (2008).

¹²⁵ It may be added that currently not all households of the addressable customer base might even have a PC at home, thereby further reducing the addressable market.

The potential customer base which lives in high density areas is higher in France than it is in Germany. In the three urban clusters 6.3 mill. or 18.6% of all customers are located (see Table 17). 55.6% of all customers are located in rural areas.

Table 17: Spatial distribution of the customer base in France

France			
Cluster Type	Customer Base		
	in mill.	in %	accumulated %
Dense Urban	0.9	2.6	2.6
Urban	1.4	4.2	6.8
Less Urban	4.0	11.8	18.6
Dense Suburban	2.2	6.6	25.2
Suburban	3.2	9.5	34.7
Less Suburban	3.3	9.6	44.3
Dense Rural	6.2	18.3	62.6
Rural	12.7	37.4	100.0
Total	33.9	100.0	

Source: WIK-C

The parameters in Table 18 show that the French PSTN network is relatively decentralised measured by the number of MDFs but relatively centralised measured by the number of street cabinets. On average, 9 street cabinets are connected to one MDF. This structure of the network also implies that the average sub-loop length is relatively long (750 m). This length makes VDSL a more or less unattractive NGA technology for France.

Table 18: Structural parameters of the PSTN network in France

Structural parameter	Value
Total number of main distribution frames	~ 12500
Total number of street cabinets	~ 115000
Average sub-loop length (in metres)	~ 750

Source: WIK-C

Also for France we assume a further increase of broadband penetration to 80%. Around 20% of all customers are expected only to subscribe to a single play telephony service. French operators have been very successful in marketing triple play services. More than 10% of all TV users receive their signal via IPTV which is the highest number in Europe. This success is achieved in part by the pricing policy applied by the operators. Most offerings do not differentiate between double and triple play services. We applied this assumption for our model calculation.

Table 19: Assumptions on average revenues per subscriber in France

Type of subscriber	Average revenue per subscriber (in €)	Share of the total customer base (in %)
Single Play	20.0	18.2
Double Play	45.0	59.1
Triple Play	45.0	13.6
Business	65.0	9.1
Total	42.3	100.0

Source: WIK-C

The weighted average of the ARPU used for the model calculations is assumed as 42.3 € per month and subscriber. This average number is comprised of the elements as set in Table 19.

For all scenarios we assume a WACC of 10.25%, which is to approximate the interest rate the Regulatory Authority uses to calculate ex ante regulated wholesale services of France Telecom. For some scenarios for France we will show the impact of an increased WACC assumption on the model results.

5.2.2.2 Model scenario results

Because VDSL is not a relevant NGA scenario in France, we concentrate here on FTTH roll-out scenarios. According to our results in Table 20, France Telecom could profitably roll out a FTTH-PON network up to the dense suburban cluster or for up to 25.2% of the broadband customer base. In the dense urban and urban clusters which together represent a potential customer base of 2.3 mill. subscribers the incumbent only needs moderate market shares for a viable business case (18% and 32%, respectively). This reflects the high density concentration of customers in these areas (mainly in Paris) and favourable cost conditions. In the other two clusters with viable roll-out opportunities, the critical market shares jump up to 80% and 87%. This reflects less favourable conditions regarding density as well as regarding cable instalment.

Table 20: Critical market shares under different market and regulatory scenarios for rolling-out FTTH-PON in France¹²⁶

PON - FR									
Cases	First Mover Cases		Second Mover Cases						
	Accumulated Customer Base	Stand Alone	Incumbent	80% Infrastructure Sharing	20% Infrastructure Sharing	SLU + 80% Dark Fibre and Infrastructure Sharing	SLU + 80% Dark Fibre and Infrastructure Sharing	SLU + 20% Dark Fibre and Infrastructure Sharing	SLU + 20% Dark Fibre
Dense Urban	2.6%	19%	18%	32%	32%	5%	5%	10%	10%
Urban	6.8%	34%	32%	37%	37%	6%	6%	15%	15%
Less Urban	18.6%	83%	80%	97%	98%	7%	6%	11%	11%
Dense Suburban	25.2%	92%	87%	98%	n.v.	13%	12%	23%	23%
Suburban	34.7%	n.v.	100%	n.v.	n.v.	16%	13%	24%	24%
Less Suburban	44.3%	n.v.	n.v.	n.v.	n.v.	24%	21%	33%	33%
Dense Rural	62.6%	n.v.	n.v.	n.v.	n.v.	62%	86%	85%	91%
Rural	100.0%	n.v.	n.v.	n.v.	n.v.	n.v.	n.v.	n.v.	n.v.

n.v. = Not viable
Source: WIK-C

¹²⁶ The percentage values in the table indicate the critical market shares for profitability, i.e. the revenue – cost break even.

On the basis of duct access, alternative operators could profitably roll out only in the dense urban and urban cluster or for 6.8% (2.3 mill.) of the potential broadband customer base. Their business cases do not only look profitable, at least one operator can also replicate the infrastructure of the incumbent, because the critical market share of 32% and 37% seem to be achievable. If we take account of the very special conditions the French operators could benefit from using the sewers¹²⁷ to install fibre cable, the infrastructure costs can be reduced significantly, mainly in the dense urban cluster and to some extent in the urban cluster. In the dense urban area these special roll-out conditions decrease the critical market share from 32% to 22%. The potential for competition is therefore enlarged significantly, potentially enabling two competitors to replicate the incumbent's roll-out.

The potential for competition will be extended significantly if there is no need for fibre infrastructure duplication inhouse and in the distribution cable segment. If fibre SLU is available and competitors have access at the OSDF at a relevant mutualisation point, the critical market shares go down to a range of 5% and 15% for alternative operators. In that case, viable competition seems to be a relevant market outcome because several competitors have the chance to replicate the incumbents' NGA roll-out. This result holds for any cluster where a first mover could profitably roll-out a FTTH network.

Table 21 summarises our model results if the operators choose to build the FTTH network in a P2P architecture. A profitable roll-out of P2P by a first mover is limited to the less urban cluster or for 18.6% of the potential customer base. In the less urban cluster even the incumbent would need a 89% market share. The required market share is of course lower in the dense urban and urban cluster.

127 The rights of way in a sewer in Paris are charged with 1€ per meter and year in the model regardless of the amount of cables being installed.

Table 21: Critical market shares under different market and regulatory scenarios for rolling-out FTTH-P2P in France¹²⁸

P2P - FR					
Cases		First Mover Cases		Second Mover Cases	
Cluster	Accumulated Customer Base	Stand Alone	Incumbent	80% Infrastructure Sharing	20% Infrastructure Sharing
Dense Urban	2.6%	22%	20%	33%	39%
Urban	6.8%	47%	45%	38%	46%
Less Urban	18.6%	92%	89%	n.v.	n.v.
Dense Suburban	25.2%	n.v.	n.v.	n.v.	n.v.
Suburban	34.7%	n.v.	n.v.	n.v.	n.v.
Less Suburban	44.3%	n.v.	n.v.	n.v.	n.v.
Dense Rural	62.6%	n.v.	n.v.	n.v.	n.v.
Rural	100.0%	n.v.	n.v.	n.v.	n.v.

n.v. = Not viable

Source: WIK-C

Alternative operators, even if they have duct access, need higher critical market shares and can roll out FTTH only for the first two clusters. Because the critical market shares in both clusters are below the threshold, the incumbent's FTTH roll-out is replicable in these two clusters. This result holds under the assumption that duct access is available at a level of prices currently discussed in France.

If we assume that the operators have access to the favourable conditions of using sewers in Paris for installing fibre cables, replicability can be improved significantly. E.g. the critical market share in the dense urban cluster would go down to 22%, allowing replicability at least theoretically for more than one alternative operator.

¹²⁸ The percentage values in the table indicate the critical market shares for profitability, i.e. the revenue – cost break even.

5.2.2.3 Summary of results

Figure 38 and Figure 39 below describe the roll-out conditions for the various NGA technologies. Figure 38 represents the roll-out conditions of the incumbent. For the results in Figure 39 we have assumed the (very) optimistic infrastructure sharing scenario that the alternative operator can use for 80% of its cabling needs empty ducts of the incumbent.

Figure 38: NGA roll-out opportunities of the incumbent by technology in France

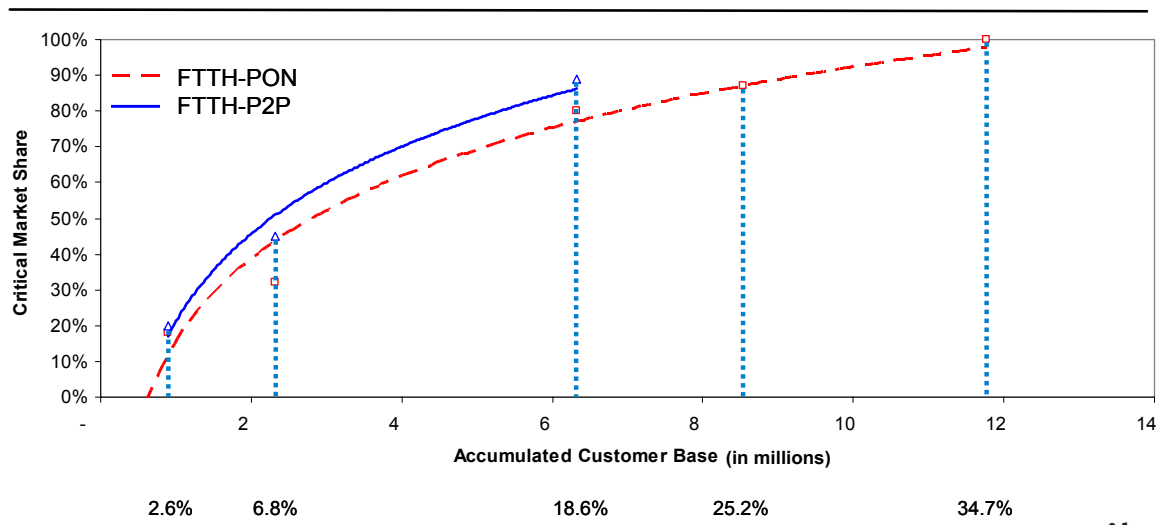

Source: WIK-C

Figure 39: NGA roll-out opportunities of an alternative operator in case of 80% infrastructure sharing in France

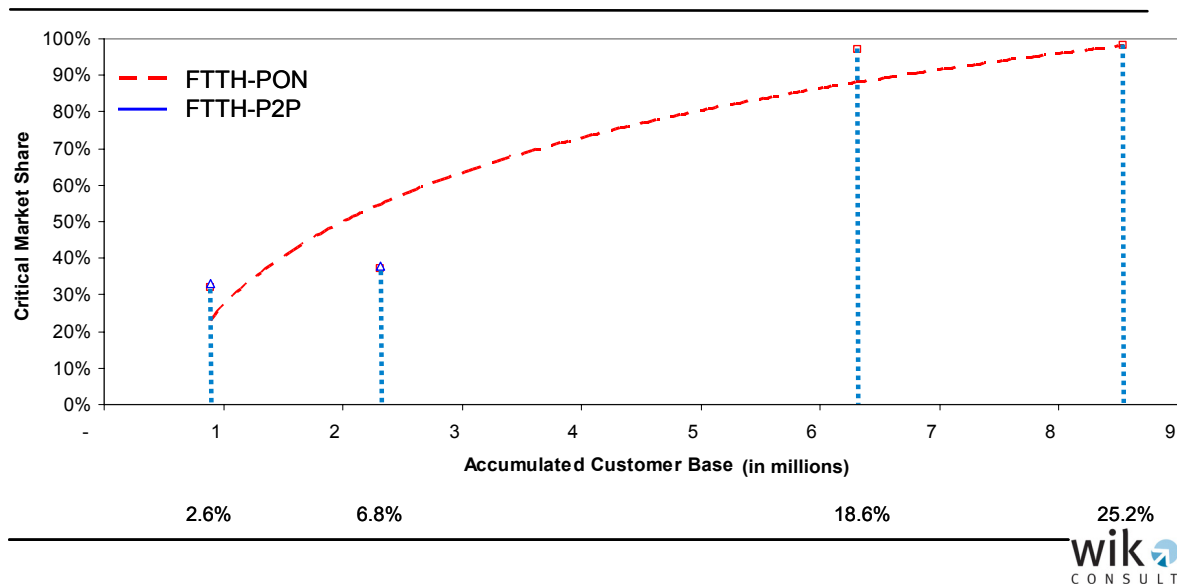

Source: WIK-C

The main results for France are the following:

- (1) Due to the (copper) sub-loop length VDSL is not a viable technology in France.
- (2) A profitable FTTH roll-out is limited to 25.2% of the potential customer base.
- (3) The P2P architecture is characterised by higher investments and costs compared to the PON architecture in most cases and scenarios.
- (4) Alternative operators can rollout FTTH to a lesser degree than the incumbent even under optimistic infrastructure sharing assumptions.
- (5) The low cost access to sewer infrastructure in Paris increases the profitability and replicability of fibre infrastructure significantly.
- (6) Replicability is in most cases limited to one alternative operator.
- (7) Fibre LLU in case of P2P and fibre SLU in case of PON increases replicability significantly and enables viable competition in all cluster where a first mover rolls out the FTTH infrastructure.

5.2.2.4 WACC Sensitivities

In the context of NGA it is currently being discussed to use the WACC as a vehicle to reflect a potentially higher risk compared to wholesale services in the PSTN

environment. Incumbents argue that financial institutions would ask for a different interest rate to finance the NGA roll-out. We do not intend to enter into this discussion. The model assumes in a future proof manner the incumbents to completely exchange the access network and migrate all customers to the new network infrastructure, thus being enabled to simply upgrade the customers on demand (by software command).

The results of lifting the WACC for the incumbent cases up to 15% are shown in Figure 40 and Figure 41.

Figure 40: WACC of 10.25 vs. 15% in the case incumbent PON in France

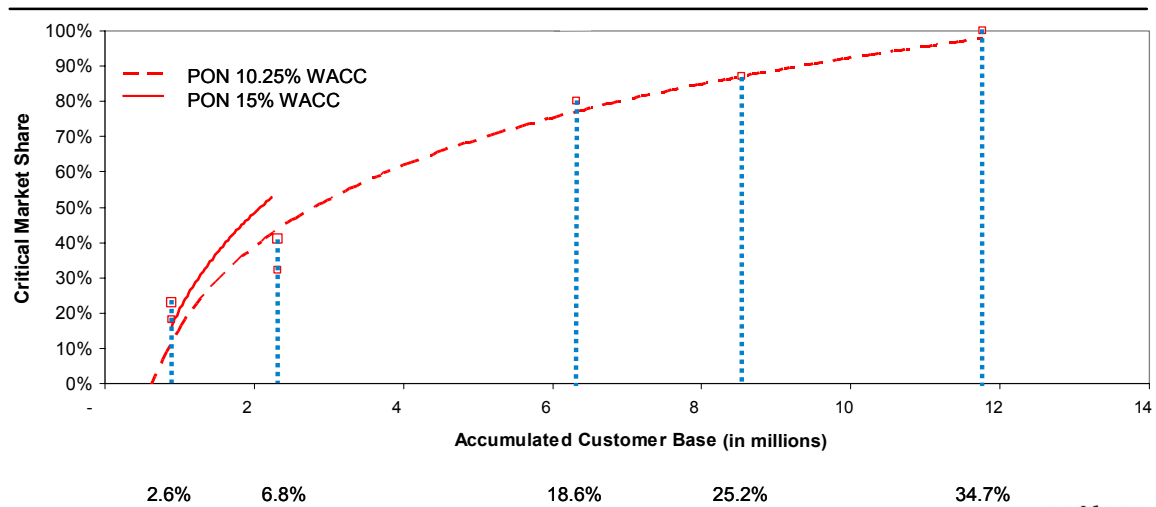

Source: WIK-C



Figure 41: WACC of 10.25 vs. 15% in the case of P2P in France

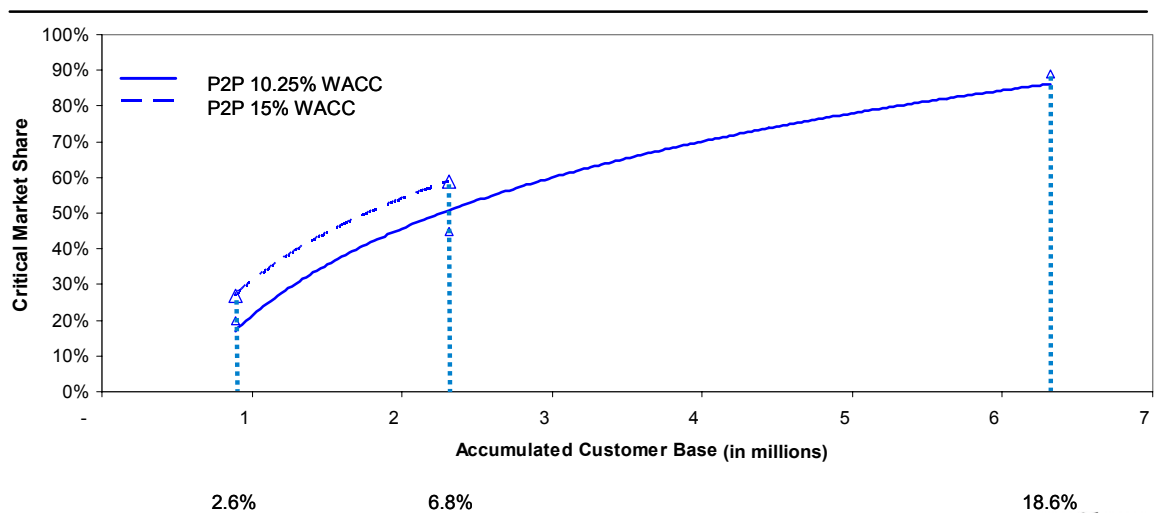

Source: WIK-C



When increasing the WACC to 15 %, the model reacts by increasing the critical market share and reducing the area which can be covered in a viable manner. The critical market share in the PON case increases by 5 percentage points in the dense urban cluster and by 9 percentage points in the urban cluster, and the addressable customer base is reduced from below 18.6% to above 6.8%. In the P2P case the critical market share increases by 7% in the dense urban and 14% in the urban cluster. This is the reaction one can expect: Increasing the interest fee results in a business case being less profitable.

Another discussion recently started is the possibility to increase the WACC for the calculation of the regulated wholesale prices of the SMP operators in order to consider the investment risk appropriately in a scenario in which access obligations apply. Thus in the PON SLU case the price for the fibre sub-loop should have to be calculated with an increased WACC. Figure 42 shows the result of increasing the WACC from 10.25% to 15% for the SLU price only. The critical market shares of a second mover which uses SLU as an input increase significantly and the viable addressable customer base decreases. The increase of the critical market share is between 14 percentage points for the dense urban cluster and 35 percentage points in the suburban cluster. The decrease of the addressable customer base from 62.6% to 34.7% is in reality not relevant, because fibre SLU can only be used where the incumbent rolls out PON (according to the model results the urban clusters only).

If the increased WACC would as well be applied to the duct rental fees, the result would affect competition further.

Figure 42: WACC of 15% applied on SLU fee in the case of PON SLU 80% infrastructure sharing in France

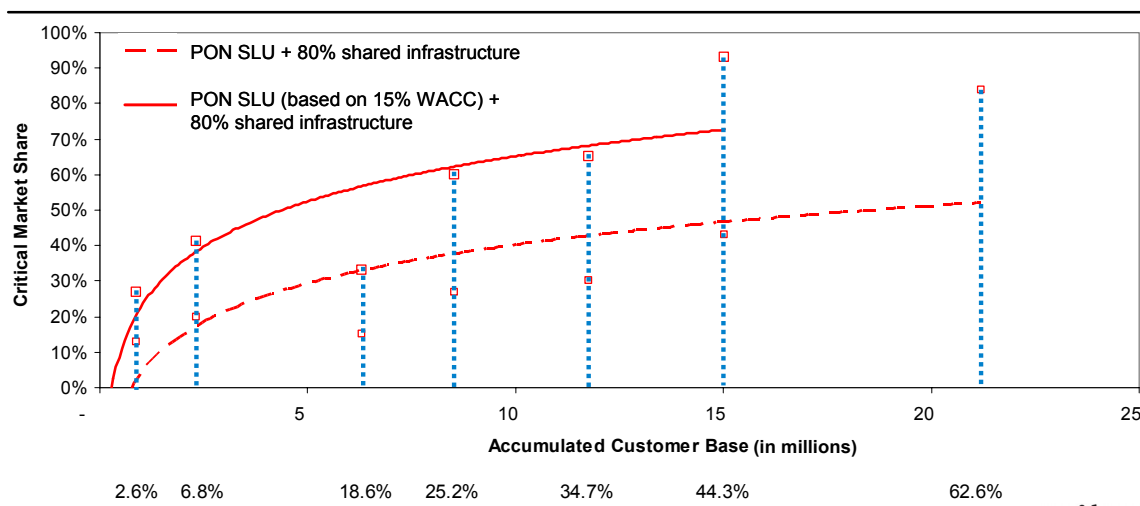

Source: WIK-C

Increasing the WACC for the calculation of wholesale services results in discouraging infrastructure investments of the competitors.

5.3 Italy

5.3.1 Market developments and regulatory background

5.3.1.1 Strategic positioning of the main players in the broadband market¹²⁹

Background

In Italy there are about 11,300 MDFs and about 145,000 street cabinets. The average length of the local loop (distance between Central Office and end user) in Italy is about 1.2 km. About 90 % of the population live within a distance of 3 km from the Central Offices. The average sub-loop length is about 400 m.¹³⁰

According to the European Commission's 13th Implementation Report, Telecom Italia has a market share of 63.6 % regarding the fixed telephony market (by retail revenue) and also a market share of 63.6 % of fixed broadband access lines (comprising DSL, cable, FTTB/H, satellite, powerline communications and other technologies).

Telecom Italia

Telecom Italia (TI) has announced in March 2007 its plans for the Next Generation Access Network ("NGN 2"). The main elements of this project are:

- Implementation of an All-IP network;
- Deployment of deep fibre in the local loop with a mix of technologies, comprising FTTCab and FTTB solutions (especially in main cities);
- Installation of VDSL2 technology aiming at a coverage of up to 65 % of the population;
- About 65 % of the lines will be covered by the new network with broadband downloading capacity up to 100 Mbps, the remaining 35 % will be served by FTTE¹³¹/ADSL 2+ solutions;
- Total project Capex is around 6.5 bill. Euro.

¹²⁹ The following information relies heavily on Amendola and Pupillo (2008) and Pileri (2008) as well as on interviews with experts from Italian ECTA members.

¹³⁰ See AGCOM (2007, p. 39).

¹³¹ FTTE stands for Fibre To The Exchange, thus, denoting a deployment of fibre infrastructure to the MDF.

Telecom Italia is starting the NGN2 activities in Milan. The network deployment in Milan is based on Metroweb's infrastructure, see below. In Milan, Telecom Italia seems to follow an FTTB approach with the installation of active VDSL equipment in the basement of the buildings. TI has concluded a 15 years agreement with Metroweb (renewable for another 15 years) enabling to reach 70,000 buildings in Milan. Pupillo (2008) reports that TI will be using no more than eight fibre strands out of a cable made up of 24 to 96 fibres.

Pileri (2008) reports that Telecom Italia's deployment of NGN 2 is accompanied by a "reduction of the number of central offices according to the new distance to the buildings that can be over 10 km (reduction of a factor 5) and reduction of power budget per line (10W to 3 W)". Stefano Nocentini, the Director of Networks of Telecom Italia, stated at ECTA's recent NGA Workshop¹³² that the number of Central Offices will be even reduced "from 10,000 to less than 1,000".

Fastweb

As of end of 2007 Fastweb's network comprises about 26,500 km, covering 45 % of the Italian population (about 10 mill. homes). The network passes about 2 mill. homes via FTTH technology and the remaining 8 million via metallic local loop unbundling.

In areas which Fastweb serves with FTTH, Fastweb uses ducts provided by Socrate (see below) or their own ducts. For example in Turin, Bari, Naples, and Rome. Fastweb is using the Socrate infrastructure to connect about 700,000 households.¹³³ Fastweb is also using fibre from third parties e.g. in Milan, see below. Fastweb has invested 4 bill. Euros since 1999 and it has about 1.3 mill. customers (as of end of 2007).

Regarding in house cabling Fastweb can use the building infrastructure for the vertical deployment of multimode fibre.

Fibre deployments in specific city areas in Italy

In Italy there is a number of regional and local activities focusing on the deployment of fibre, mainly in around 20 cities in the Northern part of Italy. Major players in these ventures are (multi-) utilities owned by the respective cities. These local utilities have installed fibre in the ground. However, competitors view the installation as being very fragmented as fibre can be available on one side of a street but not on the other or it is available in one street of a particular area but not in the other. Thus, overall, market participants in Italy view accessibility to this infrastructure to be rather difficult and cumbersome.

¹³² ECTA NGA Workshop, June 25, 2008, Brussels.

¹³³ Our interviewee from Fastweb explained that there was no official price list, rather, Fastweb paid a *una tantum* fee per meter used on a private agreement basis.

There are, however, two exceptions: in Milan and Genova fibre infrastructure has been deployed by local entities ubiquitously and it is widely used by market participants.

In Milan a company called Metroweb is the owner of the widest distributed fibre optical network. Fastweb directly owned 23 % of Metroweb, however, these shares were sold to AEM in June 2003.¹³⁴ Metroweb operates as an independent open network access provider that offers its infrastructure to third parties which are providers of telecommunication services, thus, Metroweb is acting as a wholesale open access network provider. Metroweb is offering its fibre to many market participants in the Milano area; examples are Fastweb and Telecom Italia.¹³⁵

In Genova, Sasternet, which is a joint venture between Fastweb Mediterranea (which, however, is not the majority owner) and the local utility (AMGA), is deploying fibre. The coverage of the local network in Genova is, however, not as ubiquitous as in Milan.

Telecom Italia's Socrate Project

Telecom Italia's Socrate Project was carried out between 1995 and 1997. The focus was on Hybrid Fibre Coax technology to bring pay TV and multimedia services to Italian households. This project was completely stopped after Telecom Italia's privatization in 1999. Yet, this network provides fibre and ducts for about 1.7 m homes passed in 57 major Italian cities.¹³⁶ These ducts were opened to competition by an Antitrust Proceeding in 2001.¹³⁷ This free duct capacity of Telecom Italia has e.g. been used by e.Biscom (which merged with Fastweb in 2004).

Overall, the Socrate network covers 8 % of the Italian population. The Socrate project mainly comprised the deployment of optical rings for the selected central urban areas (covering on average between 5,000 and 15,000 households) up to specific "street cabinets" (centraline installate in armadi stradali). Between these "street cabinets" and the buildings and apartments, respectively, coaxial cable has been deployed. The average distance of the copper part of this infrastructure is about 500 m and each cabinet is reported to cover on average more than 300 apartments (unità immobiliari).

134 Today, 76.5 % of Metroweb is owned by the Stirlings Square Capital Partners Fibre Holding SCA and 23.5 % is owned by Azienda Elettrica Milanese S.p.A (AEM).

135 In May 2007 e.g. Telecom Italia signed an agreement with Metroweb to use their fibre to deploy a next generation access network in Milano. During this 15 year agreement, Telecom Italia will be able to reach 70,000 buildings in Milano with FTTB solutions. Metroweb's fibre will be used by TI only in the secondary access network, from the optical splitter of TI to the ONU in the building nearby, while it will use its own fibre in the primary access network.

136 This does not necessarily mean that Socrate fibre is usable for FTTB/H in each case.

137 Amendola and Pupillo (2008) outline that in January 2001 the Italian competition authority AGCM approved the acquisition of Cecchi Gori Communications by Seat Pagine Gialle (Telecom Italia). One of the conditions imposed was that Telecom Italia should, from March 1st 2001, provide access to duct so that alternative operators could place their fibre optic lines for the provision of interactive and multimedia services in TI's existing duct infrastructure. The access had to be provided on non-discriminatory terms and at cost oriented prices.

Overall, the optical part of Socrate comprises about 2,000 km and the coaxial part about 7,000 km.

Amendola and Pupillo (2008) claim that the Socrate network will play an important role with regard to Telecom Italia's deployment of FTTC/VDSL and FTTB solutions. However, as has been outlined above, the Socrate network is also available to other operators for NGAN investment projects.

Other existing infrastructure

Amendola and Pupillo (2008) report that "many utilities and municipalities, such as ENI, ENEL, ASM, ITALGAS... own infrastructures (ducts and fibres) that can be used to build" NGANs. Fibre infrastructure has also been deployed along railways (Ferrovie dello Stato), and highways (Autostrade Telecom, the previous telecoms arm of Società Autostrade, now owned by Infracom). This infrastructure is typically used by Italian market players for their backbone network, i.e. it is not relevant for fibre based access network deployment.¹³⁸

Market participants claim that there should be an approach to harmonize the availability of information regarding access to existing infrastructure and their commercial terms.

5.3.1.2 Regulation, *wholesale services*

Phasing out of MDFs

TI announced plans for NGN roll-out in May 2007, emphasising that one of the benefits from rolling out its new NGN infrastructure will be a significant reduction of MDF sites.

Yet, there is currently no specific discussion regarding the phasing out of MDFs in Italy. AGCOM has launched a consultation in May 2007 on NGNs and functional separation in which this issue was one of the items subject to consultation. The consultation ended in July 2007, however, AGCOM has not made any further steps.

Sub-loop unbundling

Sub-loop unbundling is already an option in TI's Reference Unbundling offer. However, market participants underline that it is not used in practice by alternative operators due to high costs and technical limitations. Indeed, they are pointing out that there is no possibility of having access to TI's street cabinets, which are very old and not able to accommodate other operators. The only alternative would be to install another cabinet.

¹³⁸ Enel and the railways are e.g. providing backbone infrastructure for Wind; ENI and Italgas are providing backbone infrastructure for Albacom/BT.

Bitstream access

Telecom Italia has been required to produce one of the most sophisticated bitstream standard offerings in Europe. In more detail, this offering comprises ATM and Ethernet based bitstream access.¹³⁹ There are 2 different quality segments for Ethernet based bitstream access and 3 different quality segments for ATM based bitstream access. Almost each of them is available at 3 different aggregation levels of the network: at the DSLAM level, at the parent node level, and at the distant node level.

Moreover, there has been an additional option for multicast in the Ethernet bitstream offering. TI has, however, appealed AGCOM's decision to impose multicast and it has won the appeal. It is therefore likely that the multicast offer will be removed. Moreover, there are concerns from some market participants that the multicast offer has technical and economical limitations.

As an incentive for unbundling there is the rule that bitstream access at the DSLAM level cannot be offered at Main Distribution Frames, at which there is already local loop unbundling in use (above 50 lines).¹⁴⁰ On the higher aggregation layers bitstream access generally has to be delivered.

Access to ducts, dark fibre

Access to ducts and/or dark fibre of TI was an option discussed in AGCOM's consultation, see AGCOM (2007). The national consultation seemed favourable to access to ducts but there is no practical implementation as of yet.

As outlined above, access to Socrate ducts and dark fibre has been enforced in 2001 by the Antitrust Authority (and not by the regulator).

Just recently (June 20, 2008), TI and Fastweb have signed an agreement which specifies reciprocal access to ducts in order to deploy more rapidly NGN infrastructure. The agreement is said to be open to all interested operators. The MoU between TI and Fastweb specifies that the two companies will cooperate with regard to:

- Planning of civil infrastructure necessary for the deployment of fibre optic networks (encompassing e.g. empty ducts along the streets) with the objective to avoid infrastructure duplication,
- Exchange, on the condition of reciprocity, of usage rights for civil infrastructures,

¹³⁹ In Italy the aggregation network is based on Ethernet instead of ATM. TI's bitstream offer in particular includes bitstream over fibre.

¹⁴⁰ If more than 50 circuits are unbundled new orders for bitstream access at DSLAM aggregation level will not be accepted anymore.

- Study of and experimentation with innovative techniques regarding civil infrastructures, e.g. the utilization of newest generation micro tubes for the deployment of optical fibre.

Access to in-house cable

AGCOM has not expressed any position on access to in-house cable yet.

5.3.2 Model results

5.3.2.1 Country specific assumptions

The total potential customer base in Italy amounts to 26.3 million customers. 23.9 million of these are residential customers (households) and 2.4 million are business customers. These numbers include mobile-only households and those which do not use electronic communications services at all. In the Italian broadband market cable up to now is of no importance. There exist no cable operators. Thus, cable can be neglected considering the competition status of the market. But there exists a medium sized mobile-only market, comprising some 17%¹⁴¹ of the total customer base.

These aspects give rise to the conclusion that fixed-line operators might not be able to address the total broadband customer base, rather only ~ 85% of it because one has to take into account the intermodal competition with the mobile operators.

The population in Italy strongly concentrates in the suburban clusters (46.1%), and with 44.6% a similar share of it is living in rural areas. The potential customer base living in high density areas (dense urban) is low (0.2%) and only 9.3% live in the three urban clusters. Thus, Italy is a country with rather strong suburban areas, compared to the other countries considered.

¹⁴¹ See EU Commission (2008).

Table 22: Spatial distribution of the customer base in Italy

Italy			
Cluster Type	Customer Base		
	in mill.	in %	accumulated %
Dense Urban	0.1	0.2	0.2
Urban	0.4	1.4	1.6
Less Urban	2.0	7.7	9.3
Dense Suburban	0.9	3.3	12.6
Suburban	1.3	5.0	17.6
Less Suburban	9.9	37.8	55.4
Dense Rural	5.5	21.2	76.6
Rural	6.2	23.4	100
Total	26.3	100.0	

Source: WIK-C

The structural data of the Italian PSTN network in Table 23 show a relatively decentralized approach according to the number of MDFs, and also a decentralized approach according to the number of street cabinets. On average, 12.8 street cabinets are concentrated to one MDF. The average sub-loop length is relatively short (~ 400 m). Thus this sub-loop length is still suitable to a satisfying VDSL transmission and as well there are no indications of other technical risks. We will therefore consider VDSL in all competitive variants of our study.

Table 23: Structural parameters of the PSTN network in Italy

Structural parameter	Value
Total number of main distribution frames	~11.300
Total number of street cabinets	~145.000
Average sub-loop length (in metres)	~400

Source: WIK-C

For Italy we assume a further increase of broadband penetration to app. 81.9%. We assume that around 18% of all customers remain subscribers of a single play telephony service and that there is only a low difference between the ARPU for double and triple play services, similar to France where IP-TV at the moment is sold as a free add-on to double play.

Table 24: Assumptions on average revenues per subscriber in Italy

Type of subscriber	Average revenue per subscriber (in €)	Share of the total customer base (in %)	accumulated %
Single Play	22.5	18.1	18.1
Double Play	44.6	59.1	77.2
Triple Play	50.6	13.7	90.9
Business	64.1	9.1	100
Average total	43.2	100.0	

Source: WIK-C

For the model calculations the revenue input is the weighted average of the ARPU of 43.2 € per month and subscriber. This average is calculated out of the ARPUs for the different services and the share these services will be bought as deployed in Table 24. This ARPU is the highest of the countries considered and is one reason why the viability is better than in other European countries.

For all scenarios we use a WACC of 13.4%, which is the interest rate the regulatory authority uses to calculate ex ante regulated wholesale services. This is the highest WACC of the country cases compared in this study.

One remarkable peculiarity in Italy is the existence of the Socrate infrastructure, which can be used by network operators to provide broadband services. In the model we take account of this infrastructure by a monthly rental for already existing empty ducts¹⁴². It is assumed to meet the operators duct needs in ~ 45% of all ducts in the distribution cable segment of the first four clusters (dense urban – dense suburban) and in 15% of all ducts in the suburban cluster.¹⁴³ We assume the usage of this already existing infrastructure already for the first mover cases (Stand-alone and Incumbent) - like the sewers in Paris. In the second mover cases the Socrate infrastructure is considered according to the percentage of infrastructure sharing as described in the specific case (80%, 20%).

5.3.2.2 Model scenario results

For Italy we consider all three subscriber broadband access architectures of this study, VDSL, PON and P2P. Table 25 to Table 27 exhibit an overview of the results of the critical market shares in each cluster.

¹⁴² The use of Socrate infrastructure is payed IRU-like as a one time fee instead (IRU: indefeasible rights of use). In our model we have transformed the one time fee into a current rent.

¹⁴³ For feeder and backhaul cable segments we did not consider Socrate ducts because of the need for higher cable concentrations, resulting in a major amount of subducts (depending on the architecture).

We start by considering the VDSL case. Our results in Table 25 show that Telecom Italia could profitably roll out a VDSL network up to the rural cluster or for the complete broadband customer base. Starting with a critical market share of 12% in the dense urban cluster the critical market share for the rural cluster ends with 80%. This large and unique coverage is due to the fact that the cost of civil engineering is lower than in Germany and in the less dense populated areas aerial cabling is used to a large extent.

The higher critical market shares needed for a first mover being not the incumbent and the decrease in coverage reflect the worse cost structure and the fact of not having an extraordinary income from dismantling MDF locations.

Table 25: Critical market shares under different market and regulatory scenarios for rolling out VDSL in Italy¹⁴⁴

VDSL - IT											
Cases	Accumulated Customer Base		First Mover Cases			Second Mover Cases					
	Cluster		Stand Alone	Incumbent		80% Infrastructure Sharing	80% Dark Fibre and Infrastructure Sharing	80% Dark Fibre and Infrastructure Sharing	20% Infrastructure Sharing	20% Dark Fibre and Infrastructure Sharing	20% Dark Fibre
Dense Urban	0.2%	13%	12%	11%	12%	12%	12%	15%	14%	14%	14%
Urban	1.6%	11%	10%	9%	10%	10%	10%	13%	12%	12%	12%
Less Urban	9.3%	17%	15%	14%	14%	14%	14%	20%	18%	18%	18%
Dense Suburban	12.6%	16%	14%	14%	14%	14%	14%	18%	17%	17%	17%
Suburban	17.6%	18%	15%	15%	15%	15%	15%	20%	18%	18%	18%
Less Suburban	55.4%	53%	13%	51%	35%	35%	51%	62%	59%	54%	54%
Dense Rural	76.6%	54%	42%	47%	42%	42%	48%	62%	58%	57%	57%
Rural	100.0%	n.v.	80%	n.v.	73%	n.v.	n.v.	n.v.	n.v.	n.v.	n.v.

n.v. = Not viable
Source: WIK-C

¹⁴⁴ The percentage values in the table indicate the critical market shares for profitability, i.e. the revenue – cost break even.

On the basis of duct access alternative operators could profitably roll out VDSL up to the dense rural clusters, but need a higher critical market share of up to 62% (for the regulatory less efficient 20% sharing model variants). The VDSL roll-out for second movers seems to be replicable up to the suburban cluster. One has to keep in mind the market shares of the incumbent and mobile operators (mobile-only). The sum of all shares has to be lower than 100%.

As we have outlined in section 5.3.1 Telecom Italia does not only intend to roll out VDSL but also FTTB/FTTH technology. Table 26 summarises the model results if the operators in Italy roll out FTTH-PON.

A profitable roll-out for the incumbent is possible only for the urban and the dense suburban and suburban clusters, thus covering only 17.6% of the total customer base. In the suburban clusters the critical market share needed is 78% and might be achievable, thus the case in this area still is profitable.

Even on the basis of duct access rolling out a second PON infrastructure is less profitable and is limited for a second mover to the dense urban and urban clusters with critical market shares of 24 and 35%, respectively (case 80% duct). Basis for this assertion is our assessment that critical market shares of above ~ 50% do not result in a profitable business case in a specific area because of an already existing fixed network competitor and the mobile-only customers.

The potential for competition increases, however, significantly if there is no need for duplicating inhouse and sub-loop cables for a second mover. If fibre sub-loops from the splitter location are available, the second mover only needs to rent the customer access lines required to connect the active customers. In turn, our model results yield that the critical market shares fall below 26%.in the regulatory efficient cases of 80% sharing¹⁴⁵. Under these circumstances viable competition seems to be a relevant market outcome because several operators have the chance to replicate the incumbent's PON roll-out at least in the densest clusters. The replicability result holds for all clusters where a first mover can roll out a PON network profitably.

145 In the Italian cases the critical market share for the fibre SLU approaches is higher than in other countries. This is due to the fact that the prices for the fibre SLU are calculated as an average of the total cost of the incumbent over all clusters where the roll-out of PON is viable for the incumbent (in Italy the suburban cluster, thus PON is viable longer than in other countries, thus the fibre SLU price is higher and will be used as well in the denser populated clusters).

Table 26: Critical market shares under different market and regulatory scenarios for rolling out FTTH-PON in Italy¹⁴⁶

PON - IT										
Cases	First Mover Cases		Second Mover Cases							
	Accumulated Customer Base	Stand Alone	Incumbent	80% Infrastructure Sharing	20% Infrastructure Sharing	SLU + 80% Dark Fibre and Infrastructure Sharing	SLU + 80% Dark Fibre and Infrastructure Sharing	SLU + 80% Dark Fibre and Infrastructure Sharing	SLU + 20% Dark Fibre	SLU + 20% Dark Fibre
Dense Urban	0.2%	25%	25%	24%	31%	18%	18%	18%	17%	17%
Urban	1.6%	32%	31%	35%	38%	20%	20%	20%	23%	23%
Less Urban	9.3%	51%	49%	52%	61%	27%	27%	27%	30%	30%
Dense Suburban	12.6%	62%	60%	63%	75%	23%	23%	23%	51%	51%
Suburban	17.6%	81%	78%	77%	94%	26%	26%	26%	65%	65%
Less Suburban	55.4%	n.v.	n.v.	n.v.	n.v.	62%	84%	84%	n.v.	n.v.
Dense Rural	76.6%	n.v.	n.v.	n.v.	n.v.	90%	74%	74%	n.v.	n.v.
Rural	100.0%	n.v.	n.v.	n.v.	n.v.	n.v.	n.v.	n.v.	n.v.	n.v.

n.v. = Not viable
Source: WIK-C

¹⁴⁶ The percentage values in the table indicate the critical market shares for profitability, i.e. the revenue – cost break even.

Table 27 describes the results for a FTTH P2P architecture in Italy. A profitable roll-out for the incumbent would be limited to the 3 urban and the dense suburban clusters or to 12.6% of the customer base. In the dense suburban cluster the incumbent would need a critical market share of 70%.

Table 27: Critical market shares under different market and regulatory scenarios for rolling out FTTH-P2P in Italy¹⁴⁷

P2P - IT					
Cases		First Mover Cases		Second Mover Cases	
Cluster	Accumulated Customer Base	Stand Alone	Incumbent	80%	20%
				Infrastructure Sharing	Infrastructure Sharing
Dense Urban	0.2%	26%	25%	38%	36%
Urban	1.6%	34%	32%	57%	45%
Less Urban	9.3%	56%	53%	78%	74%
Dense Suburban	12.6%	73%	70%	n.v.	n.v.
Suburban	17.6%	93%	94%	n.v.	n.v.
Less Suburban	55.4%	n.v.	n.v.	n.v.	n.v.
Dense Rural	76.6%	n.v.	n.v.	n.v.	n.v.
Rural	100.0%	n.v.	n.v.	n.v.	n.v.

n.v. = Not viable

Source: WIK-C

Alternative second mover operators even with duct access need higher critical market shares compared with the incumbent and can roll out P2P in the first two clusters only, thus serving a customer base of only 1.6%. But requiring a critical market share between 36 and 45% it already depends on the market share of the other operators if a roll-out is replicable.¹⁴⁸

¹⁴⁷ The percentage values in the table indicate the critical market shares for profitability, i.e. the revenue – cost break even.

¹⁴⁸ The second mover case reveals a situation in which the 20% infrastructure using second mover has a slightly minor critical market share than the 80% infrastructure sharing operator. The reason why this can appear on the basis of the model assumptions is described in the context of Portugal, see end of section 5.4.2.2,

5.3.2.3 Summary of results

Figure 43 and Figure 44 below describe the roll-out conditions for the various NGA technologies in Italy. While Figure 43 describes the roll-out conditions of an incumbent, Figure 44 describes the results for an alternative operator under the optimistic assumption of infrastructure sharing, where we assume that under effective regulation 80% of the cables needed can use already existing infrastructure (ducts and/ or poles for aerial cabling) of the incumbent.

Figure 43: NGA roll-out opportunities of the incumbent by technology in Italy

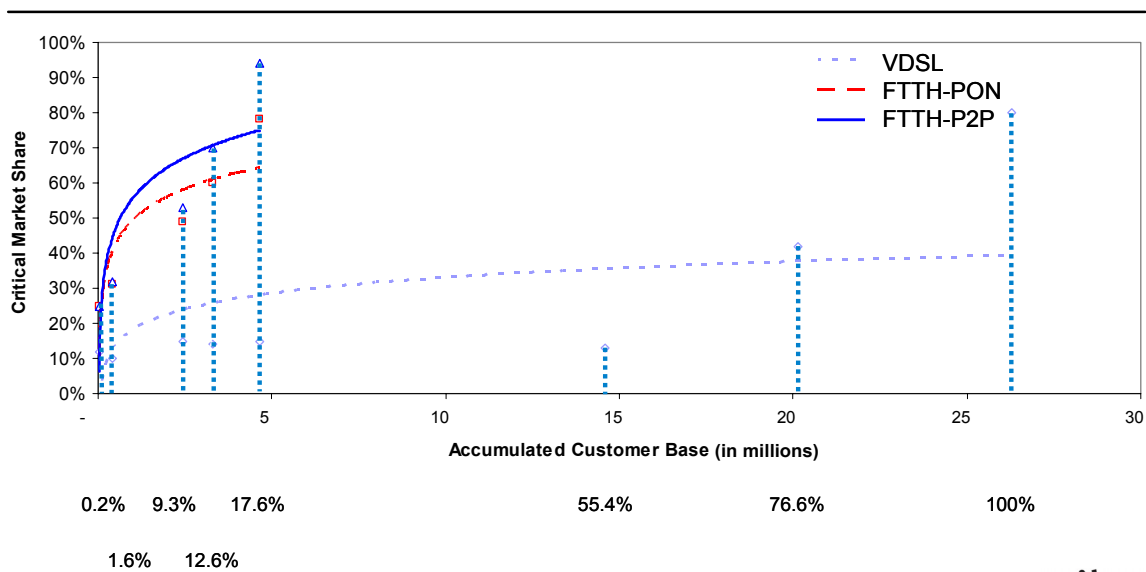

Source: WIK-C

Figure 44: NGA roll-out opportunities of an alternative operator in case of 80% infrastructure sharing in Italy

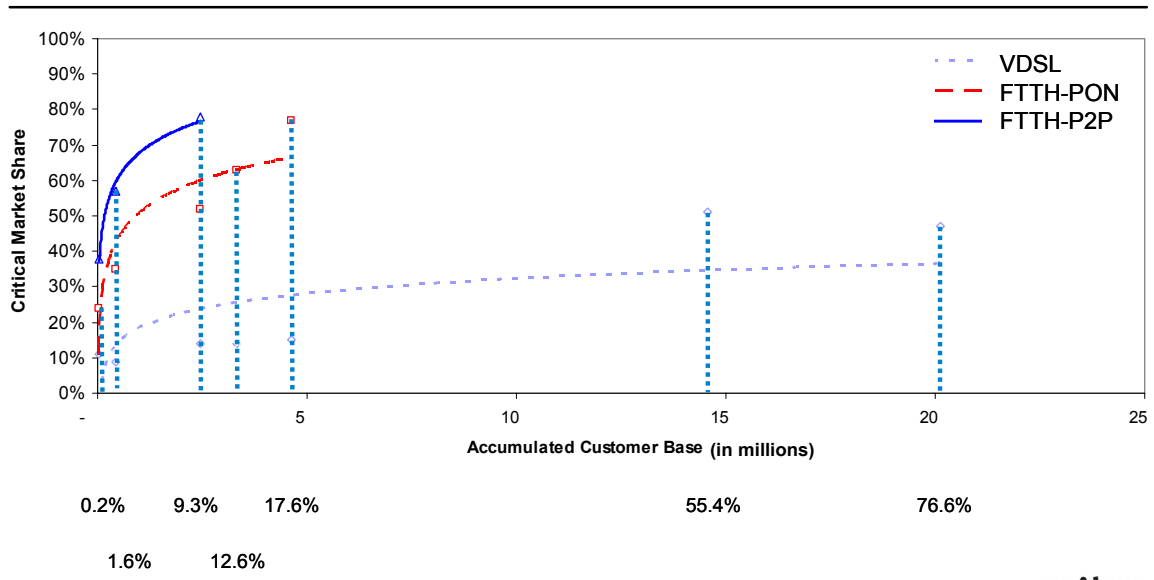

Source: WIK-C

The main results for Italy are the following:

- (1) VDSL is a profitable solution for the incumbent for the total customer base, while a first mover only could be profitable down to the dense rural cluster or 76.6% of the customer base.
- (2) The relatively high ARPU improves the viability results.
- (3) A profitable FTTH P2P roll-out is limited to 12.6% of the potential customer base.
- (4) The FTTH architectures need a higher investment and cause higher costs compared to VDSL.
- (5) The P2P architecture is characterised by higher investments and costs compared to the PON architecture in all cases and scenarios.
- (6) Alternative operators can roll out FTTC/FTTH to a lesser degree than the incumbent even under optimistic infrastructure sharing assumptions.
- (7) Replicability of VDSL is given for some operators in the urban and part of the suburban clusters.
- (8) Replicability of FTTH is, if at all, limited to one or two alternative operators and is restricted to a small (urban) customer segment (1.6% of the customer base).

- (9) Fibre LLU in case of P2P and fibre SLU in case of PON increase replicability and enable viable competition in the clusters where a first mover rolls out the FTTH infrastructure.
- (10) The FTTH cases for second movers show, that the mix of dark fibre, shared infrastructure and self constructed infrastructure may end up in economically more favourable solutions than the pure use of shared infrastructure (e.g. empty ducts). This is due to the need of fibres or subducts, that the use of own cables may be cheaper than the rental of single fibres or the construction of own ducts may be cheaper than the rental of subducts (e.g. in the case of many parallel subducts needed in the backhaul segment of a P2P architecture). Thus a choice of regulatory measures is needed to improve replicability.¹⁴⁹

5.4 Portugal

5.4.1 Market developments and regulatory background

5.4.1.1 Strategic positioning of the main players in the broadband market

Background

In Portugal there are about 2.200 MDFs. Exact information about the number of street cabinets and the average sub-loop length, respectively, are not publicly available (see section 5.4.2.1 for the assumptions made).

Broadband access infrastructure in Portugal is mainly based on ADSL/ADSL 2+ technology and CATV. Up until now, VDSL is not deployed in Portugal and no VDSL deployment plans have been announced so far.

The fixed broadband penetration (as of Q2 2008) is at 14.8 % and mobile broadband penetration is at 18 %. As of Q2 2008 there are about 1.57 mill. fixed broadband customers in Portugal.¹⁵⁰

According to the European Commission's 13th Implementation Report, Portugal Telecom has a market share of 73.6 % regarding the fixed telephony market (by retail

¹⁴⁹ The model calculates endogeneously the costs of the efficient service provision of the incumbent. If, however, price regulation for access services switches to a different regime then the model results might change.

¹⁵⁰ See <http://www.anacom.pt/render.jsp?contentId=627479>.

revenue) and a market share of 66.8 % of fixed broadband access lines (comprising DSL, cable, FTTB/H, satellite, powerline communications and other technologies).¹⁵¹

Portugal Telecom (PT)

PT has a triple play offering in the market which was launched around one year ago and which has been quite successful in attracting customers.

Recently an upgrading of PT's network to "remote network points" was observable.¹⁵² This has been viewed by some market participants as part of a VDSL preparation.¹⁵³

APRITEL has asked the regulator to stop this roll-out. Their argument is that there should be obligations on PT when they construct new infrastructure to consider sufficient capacity/space in ducts and street cabinets for sharing it with the competitors.

Moreover, PT has initiated tests regarding FTTH in specific zones (dedicated city centres). This could suggest a mixed architecture strategy for the incumbent.

It is unclear which and how many access areas (MDFs) are affected by PTs migration plans. Overall, it seems that there is little knowledge and transparency in the market and with the regulator alike about PT's NGA plans. Moreover, no NGN deployment plan has been published so far.

Sonaecom

Sonaecom is active both in the fixed and mobile market segment. As of September 2007 there are nearly 800,000 fixed-line (residential and business) revenue generating units (RGUs), 240,000 of which are DSL RGUs, including triple play customers. Sonaecom Mobile (Optimus Telecomunicacoes) offers mobile voice telephony and mobile broadband services (3G) to about 2.7 mill. SIM cards. As of the end of Q1 2008 there were 521,000 RGUs with direct access (ULL and leased line access) and 255,000 RGUs with indirect access (Wholesale Line Rental and pre-selection).

In February 2008 Sonaecom has announced a 240 mill. Euro investment focusing on the deployment of FTTH in the next three years. The objective is to reach 1 mill. homes passed (roughly a quarter of Portugal's population of around 10.6 mill.). The network will be based on G-PON technology. Sonaecom aims at reaching breakeven from FTTH

151 The President of the regulatory authority in Portugal, Amado da Silva, reports that in the fixed segment, the PT Group accounts for a market share of 38 % and the Zon Group has a market share of 27 %. OLOs account for a market share of 35 %, see Amado da Silva (2008). For further information about the market players mentioned see below.

152 We understand this to mean that new street cabinets have been established (replacing old ones), replacing the need for a central hub (MDF).

153 Obviously, there are "remote access points" where sub-loop unbundling can in principle be achieved. However, market participants claim to have knowledge of several of these remote access points which are, for example, garages and other sites, besides street cabinets. It is argued that the incumbent has still no process available for collocation at these sites.

operations within five years and total payback in nine years. Sonaecom plans this network to be an “open access network”.¹⁵⁴

Sonaecom is currently offering triple play services on the basis of ADSL and ULL.

Vodafone

Vodafone is currently very active in the fixed broadband market, having launched a ULL based offer on 15 June 2007. However, up until now there is no triple play offer.

Onitelecom

Onitelecom is currently active in the corporate and the wholesale markets and owns an extensive fibre optic network. Onitelecom provides voice, data, broadband internet and managed services to customers in the aforementioned markets. Until early 2007 Onitelecom was also present in the residential and SOHO markets with double play broadband services (voice and internet). However, the company abandoned these markets and focused on corporate customers and carriers after a change in its stockholders. Onitelecom uses several types of access networks, including direct fibre access. The core network of Onitelecom is already a full-NGN.

AR Telecom

AR Telecom is an alternative telecom operator focused since 2005 on triple play services (TV, broadband Internet and telephony) to the residential market as well as voice and data services to SMEs and corporate customers. Triple play services are provided through Fixed Wireless Access technologies in the 27.5-29.5 GHz frequency band, both in Lisbon and Oporto.

Cable operators

The market structure in the Portuguese cable market has changed substantially in the past years. Previously, it was consisting of one important national player, Zon Multimedia, and several regional players. Since about a year, however, consolidation is taking place.

Zon Multimedia is the spin-off of cable activities of PT (former PT Multimedia). Zon Multimedia currently installs DOCSIS 3.0 technology and aims at deploying FTTH infrastructure by 2010. Zon announced investment outlays of €140 - 180 mill. for the next 3 years (2008-2010) regarding DOCSIS 3.0 covering 3.1 mill houses.

¹⁵⁴ Critics claim that G-PON “isn’t proven for that kind of environment”, see Light Reading Europe, February 21, 2008. Thus, it will be interesting to see how the access issue actually will be managed.

Pluricanal and Bragatel were regional cable operators being active outside Lisboa and Oporto. They focus on medium sized cities and are active as ISP and fixed voice providers. Zon Multimedia bought them in May 2008, adding 30,000 cable TV clients to its customer base.

TvTel, a regional cable operator (focusing on the Oporto area), which also runs a satellite operation and a fibre network in Oeiras, was also bought by Zon Multimedia in January 2008, adding 70,000 cable TV clients. TV TEL has announced a €7M investment in fiber deployment in the Lisbon Metropolitan area.

Cabovisão, remains the last independent regional cable operator, owned by the Canadian Media Group Cogeco. It was the first operator to launch a triple play offer in Portugal and had 712,000 RGUs by March 2008. It is currently upgrading its network to provide HDTV services.

Market players with infrastructure potentially relevant for telcos

Portuguese altnets report that the country's utilities (from the electricity, highways, railroad, water supply sectors) have granted access to their infrastructures. However, this is mainly done at the backhaul level and without a thorough commercial approach. Coverage of the territory is concentrated mainly on the Lisbon-Porto axis. Outside this area there are few alternatives to the incumbent.

As to municipalities, there are currently several cases where local administrations are beginning to open their ducts on a wholesale basis. These approaches are, however, still scarce due to, among other factors, a lack of geographic coverage of these infrastructures. Moreover, charges are a concern for telecoms operators, i.e. the operators view Portuguese municipalities to provide duct access primarily as a way to expand municipality revenues and not as a means to support broadband roll-out in their territory. Thus, they argue that only with a change of perspective, provided a sufficient coverage of these duct networks is reached, a viable alternative to PT's offer for altnets could be created, see below.

5.4.1.2 Regulation, *wholesale services*

Duct access

Portugal is the only country in Europe with an active reference offer for 'duct access'. This is mandatory for PT and not based on SMP, rather, there is a direct obligation for PT to provide this access by the Portuguese National Law.¹⁵⁵ Access to ducts in Portugal does not include access to poles, but PT, recently, has provided altnets with the possibility to use such infrastructures.¹⁵⁶

The regulatory authority in Portugal, Anacom, has ordered in July 2004 that PTC (Portugal Telecom Comunicacoes – the fixed network company) has to make available a reference offer (RO) for access to ducts and related infrastructure.¹⁵⁷ Amado da Silva (2008), the President of Anacom, reports that guiding principles of the RO are e.g. that the RO rules must result in efficient and effective procedures. In particular, the RO includes a procedures handbook and technical specifications (namely for cable installation, intervention and removal), which need to be followed by beneficiary entities.

Duct access seekers consider the prices for duct access to be fair – a price list is publicly available. However, the process for gaining access to ducts is considered complex and open to abuse. A specific request for a particular route has to be submitted in Word format. PT then has 15 days to answer, i.e. it has to check if the required duct (route) and space is available. If space is available the actual installation request is submitted. If no space is available PT must suggest a new route. PT has installed a “booking system” to handle multiple requests for the same route. After PT has agreed to a request by a company there are 30 days within which the respective installation has to be finalized.

All such installation works are not carried out by PT but by the altnet teams which are obliged to be accompanied by PT staff to supervise the works.¹⁵⁸ Competitors claim that this has raised concerns over delays and gaming.

The competition authority ruled on this issue in 2004 regarding a specific case put forth by a regional cable operator. At that time, the national law which obliged PT to give access to ducts was not yet in place. However, the current position of the competition authority is that all regulated issues should be addressed by the NRA and only in

¹⁵⁵ See Electronic Communications Law,
<http://www.anacom.pt/template20.jsp?categoryId=103282&contentId=159011>.

¹⁵⁶ Pole access by PT is offered on a negotiation basis. In particular, it is not a regulated service.

¹⁵⁷ The RO is available at
<http://ptwholesale.telecom.pt/GSW/PT/Canais/ProdutosServicos/OfertasReferencia/ORAC/ORAC.htm>

¹⁵⁸ Amado da Silva (2008) points out that access to ducts and associated infrastructure of PTC, for installation, intervention or withdrawal of cables, or for the performance of any service governed by the RO, is carried out by workers of the beneficiary or subcontracting companies (who must be duly identified and accredited by PTC). Moreover, he specifies that PTC informs beneficiaries of the construction of new ducts two months in advance of notification to the municipality.

specific cases should the competition authority be called on to intervene. One of the restrictions that the competition authority claims to have in its powers relates to the fact that if the NRA has approved specific rules, no misconduct by PT can be claimed if it consists in following those rules imposed by the NRA.

Anacom has required PT to establish a suitable database (Extranet). This database is to contain location and space information. Access to this database resource is operational since January 2008. Market participants claim, however, that the obligation has not yet been fully met by PT. Last year ANACOM launched a public consultation aiming at creating a national picture of all available infrastructures that may support electronic communications networks. However, no conclusions have yet been published on this issue.

Amado da Silva (2008) reports on parameters of quality of service that have been defined for the duct access offer, see next table.

Table 28: Parameters of quality of service in the Portuguese duct access environment

Parameter	Time Limit	Occurrence	Penalties for non-compliance	Limits for compensation
Time limit to reply to a request for information on underground infrastructures	5 working days	100%	€ 50 / day	60 working days
Time limit to reply to a request for occupation feasibility	15 calendar days	100%	€ 50 / day	90 calendar days
Time limit to schedule the monitoring of urgent intervention operations	8 consecutive hours	100%	$d \times$ escort service price per hour d – delay hours	n.a.
Time limit to schedule the monitoring of urgent intervention operations	24 consecutive hours	100%	$d \times$ escort service price per hour d – delay hours	n.a.
Readiness level of the monitoring service	PTC must guarantee 95% of monitoring in the requested date	95%	Value corresponding to the unavailability (x) number of affected requests	n.a.

Source: Amado da Silva (2008)

Market players have highlighted the following challenges¹⁵⁹ arising from the current duct access system:

- In reality often a permission from municipalities is required before one can really make use of a duct. Market participants underline that this can take time, thus, leading to an appreciable overhead in deployment costs. Delays in obtaining the permissions may, however, make it impossible to start works within the timeframe requested by the RO. In these cases, a new permission from PT must be obtained to access the ducts, a process which delays deployment again.
- In practice, so they claim, SLAs are virtually non-existent, i.e. several critical services are not covered. Moreover, there are considerable challenges to actually implement the penalty system for not meeting deadlines. The current regime depends on the pre-requisite of sending demand forecasts which must not differ more than 20 % from effective demand. In practice, due to several constraints (municipality authorisations, PT agreement on installation dates, etc.) that lead to an unpredictability of deployment timings, the demand forecasts are usually not met. The rule is, however, if the 20 % margin is not met, no penalties are imposed.
- No bulk requests are possible; rather, the process still rests on single request for each route.
- There are restrictions with regard to availability of space. If no space is available on a specific route requested then an alternative route can be chosen but it cannot accrue to more than 10 additional segments to the additional route length.
- PT is obliged to inform altnets of any new ducts it may build under its network roll-out plan. However, there is no obligation to install new ones on request of an altnet.
- In principle there is a right of appeal in case of conflicts, i.e. one might turn to ANACOM; however, this might take a long time.
- There is a risk (competitors have already experienced in practice) that the incumbent PT actually becomes the first mover in a specific area after having received orders from competitors.

Amado da Silva (2008) has presented newest information about the number of information requests and the actual volume of orders regarding duct access in Portugal, see next figure.

¹⁵⁹ One of our interviewees claimed that there are “many hidden obstacles regarding practice”.

Figure 45: Information requests and volume of orders in the Portuguese duct access system, January 2007 – March 2008

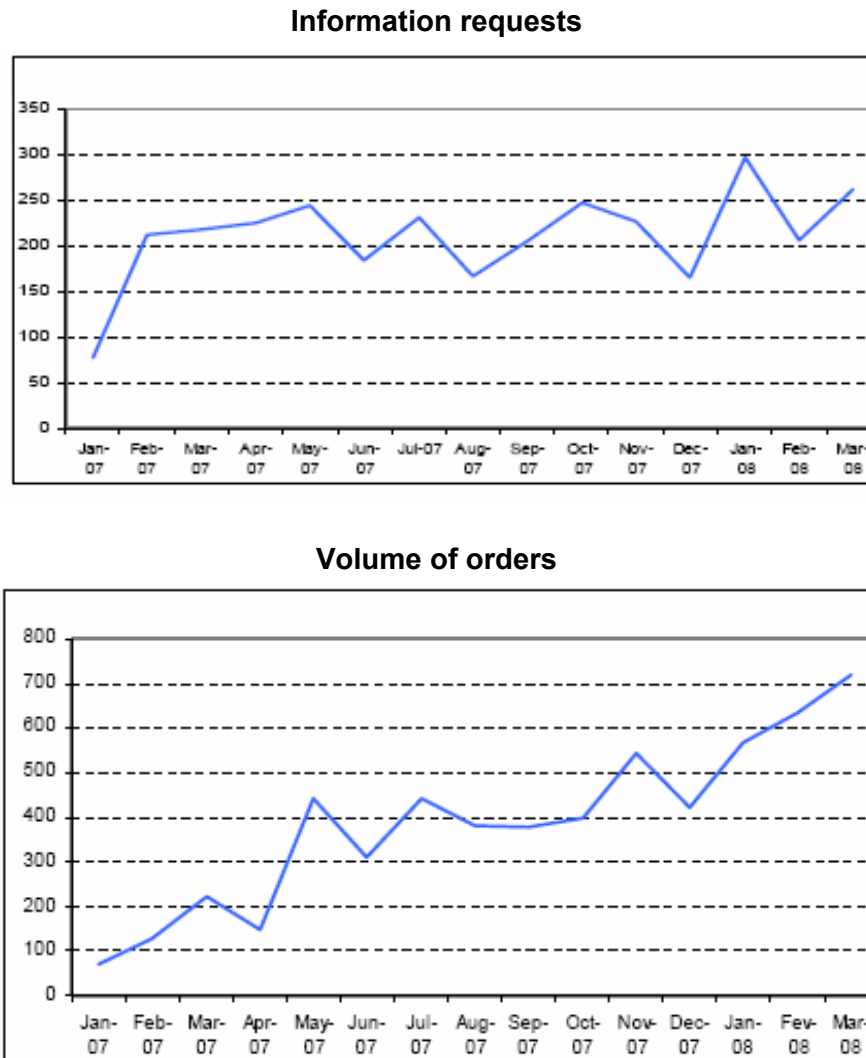

Source: Amado da Silva (2008)

The Portuguese Reference Offer¹⁶⁰ for ducts und subducts shows that their price is quoted in €/m/cm² and month (p. 28/29). In effect, this leads to a price of 0.04 € provided one assumes 4 cm² for a cable.

¹⁶⁰ See ORAC PT, Oferta de Referência de Acesso a Conduitas, PT Comunicações, 5 de Setembro de 2007.

Dark fibre

In Portugal there is no local loop dark fibre offered by the incumbent, either commercially or through regulatory obligations. Yet, PT is known to rent on a case-by-case basis dark fibre for backbone purposes of altnets. The latter consider that such an offer might be an important catalyst for NGN deployment..

Sub-loop unbundling

Although the unbundling reference offer explicitly foresees that sub-loop unbundling is possible and is subject to the same generic rules as “normal” loop unbundling, there are no unbundled sub-loops to date and the lack of detail makes it unclear as to how sub-loop unbundling would apply in practice. In particular, details concerning collocation in street cabinets have not been determined (e.g. regarding space availability inside the cabinet, space availability in the vicinity for altnet’s street cabinets backhaul solutions, etc.).

Bitstream access

Bitstream access is offered on the basis of 28 regional Pol’s and 2 national ones, where an operator may interconnect and collect the traffic. However, competitors claim that this offer is not used on a wide scale, rather, only for specific corporate solutions and by niche operators. The reason is that the economics and technical specifications impair its use from a mass market perspective (no network scalability, no freedom to choose up and downstream bandwidths, excessive pricing vis-à-vis the retail market).

A new bitstream Ethernet offer has just been launched by PT (it came into force on June 16, 2008). The practical effect of this offer in the market is as yet undetermined, but it is worth noting that the offer is unclear regarding the level of services to be available (it first states that only P1 - “best effort” level is offered but, further on, it refers to P2 and P3), thus, creating doubts on the viability of video and voice retail offers based on it.

NGN related issues

Anacom has commissioned a study from Ovum regarding the impact of NGNs on the market. This study has been published in June 2008, see Ovum (2008). The study analyses a multitude of issues that are relevant for the current and foreseeable market situation in Portugal in view of a migration to NG(A)N: (1) existing networks in Portugal, (2) competitive market situation, (3) international examples regarding NGN implementation and regulatory approaches, (4) service provision in an NGN environment, (5) scenarios of future network evolution, (6) model calculations to assess the costs of NGAN deployment across different technologies, (7) unbundling and co-location issues, (8) impact of NGN on e-inclusion, (9) interconnection in an NGN

environment, (10) impact of NGN on costs and price regulation, (11) access to buildings from a regulatory perspective and (12) profitability of NGN.

Access to in-house infrastructure

Regarding access to in-house infrastructure there are no specific rules for fibre in Portugal. Under the current rules in-house infrastructure is the property of building owners/inhabitants, thus, basically their authorisation is needed to install fibre. Some market participants claim that the Portuguese law is not clear regarding operators' rights in this regard: on one hand it states that operators have the right of access but, on the other hand, it imposes a formal authorisation without stating the conditions on which authorisation could be denied.

It seems that there are no specific rules in Portugal regarding pre-cabling of buildings with fibre. Housing companies have general obligations to ensure that new buildings have an infrastructure that enables sharing of copper infrastructure and many of them currently request the cable operator to pre-cable the buildings. However, this does not extend to fibre.

Access to relevant information

Market participants from Portugal underline that there is a need for more detailed information on PT's access network, e.g. loop length, number of local loops installed in a specific street cabinet/remote access point, list of all street cabinets/remote access points (with associated number ranges and geographic coordinates) and access to PT's geo-referenced copper loop databases. In this respect a "photograph" (cable network plan) is viewed as helpful.

Regarding infrastructures installed on public ground, the Portuguese government has established a new legal regime in 2005. This regime covers road, rail, airport, inland waterways and port infrastructure, water supply and sanitation infrastructures, gas-transmission and electricity transmission infrastructures. The regime provides rules for construction, management and access to these infrastructures. Amado da Silva (2008) points out that the administration of the mentioned infrastructures is governed by the principle of healthy competition, ensuring free access, under equal conditions, in a transparent and non-discriminatory manner, to all interested operators. Part of this regime are requirements that each administrating entity shall meet (see Amado da Silva (2008)):

- Maintenance of an updated infrastructures database,
- Implementation of a procedure to respond to information requests submitted by interested operators comprising up-to-date contact information,

- Supply, upon request, of explanatory information, namely with precise indications on location and on the existence of available capacity in infrastructures, within 45 days.

5.4.2 Model results

5.4.2.1 Country specific assumptions

The total potential customer base in Portugal amounts to 4.9 million customers. 4.45 million of these are residential customers (households including second homes) and 0.45 million are business customers. Note again that these numbers include broadband customers using cable modems for internet access, mobile-only households and those not using electronic communications services at all.

Compared to the other considered countries, cable has a relatively strong role in the Portuguese broadband market. Already 35% of all broadband customers are currently served by the cable operators. This is the strongest cable penetration compared to the other countries considered. Given the consolidation of the Portuguese cable operators under the umbrella of Zon and with the rather large second cable operator Cabovisão there might be a distinct possibility to even expand that market share for triple play services.

In addition, there is the strongest penetration of mobile-only users, being 33%, in Portugal¹⁶¹.

These aspects lead to the conclusion that fixed-line operators will not be able to address the total broadband customer base, rather only about 60% of it. Our assumption is, that some customers may buy fixed broadband access in addition to their mobile broadband because of its qualitative and economic advantages, and some will not. The market is therefore characterised by rather strong intermodal competition.

The population in Portugal is not very concentrated, with 61% of it living in rural areas. The potential customer base living in high density areas (dense urban) is low (0.9%). But 19.3% live in the three urban clusters. Thus, Portugal is a country with rather strong urban and rural areas and a minor suburban population.

¹⁶¹ See EU Commission (2008).

Table 29: Spatial distribution of the customer base in Portugal

Portugal			
Cluster Type	Customer Base		
	in mill.	in %	accumulated %
Dense Urban	0.0	0.9	0.9
Urban	0.1	2.8	3.7
Less Urban	0.8	15.5	19.2
Dense Suburban	0.2	3.6	22.8
Suburban	0.3	6.9	29.8
Less Suburban	0.5	9.2	39.0
Dense Rural	1.2	24.4	63.4
Rural	1.8	36.6	100.0
Total	4.9	100.0	

Source: WIK-C

The Portuguese PSTN network, as shown in Table 30, is relatively decentralized according to the number of MDFs, but relatively centralized according to the number of street cabinets. On average, 4.5 street cabinets are concentrated to one MDF. The average sub-loop length is relatively low (~ 350 m). Thus, this sub-loop length is suitable to a satisfying VDSL transmission. A technical problem might occur in street cabinets with high customer concentration, because the larger the amount of VDSL customer ports the more heat has to be transported outside (by ventilators) or cooled down (by air conditioning). Since the amount of subscribers per street cabinet (490) is relatively high, a possible investor in a VDSL network should consider these circumstances. Thus, the question as to whether the network structure in Portugal is well suited to VDSL can only be determined analysing these factors in detail, and therefore is beyond the scope of the present study.

Table 30: Structural parameters of the PSTN network in Portugal¹⁶²

Structural parameter	Value
Total Number of main distribution frames	~2.200
Total number of street cabinets	~10.000
Average sub-loop length (in metres)	~350

Source: WIK-C

For Portugal we assume a further increase of broadband penetration to app. 83%. Around 17% of all customers are expected to opt for single play telephony service.¹⁶³

¹⁶² These values are estimates of ECTA members based on the latest market 4 and 5 public consultation document of Anacom.

Compared to France there is a remarkable difference between the ARPU for double and triple play services. Thus, while in France IP-TV at the moment is sold as a free add-on to double play, in Portugal it is a recognizable additional service.

Table 31: Assumptions on average revenues per subscriber in Portugal

Type of subscriber	Average revenue per subscriber (in €)	Share of the total customer base (in %)	Accumulated %
Single Play	10.1	16.7	16.7
Double Play	26.8	45.8	62.5
Triple Play	52.3	20.8	83.3
Business	50.0	16.7	100.0
Average Total	33.2	100.0	

Source: WIK-C

The weighted average of the ARPU used for the model calculations is assumed as 33.2 € per month and subscriber. This average is calculated out of the ARPUs for the different services and the share these services have in the total customer base as shown in Table 31.

For all scenarios we use a WACC of 8.5%, which is the interest rate the regulatory authority uses to calculate ex ante regulated wholesale services of Portugal Telecom.

It is worth mentioning that the costs for civil engineering in Portugal are significantly lower than in the other countries considered. Thus, these input values have been adopted accordingly, being reflected as well in our interviews with the Portuguese ECTA members. Due to the low construction cost and the large amount of MDF sites in rural areas we reduced the average revenue received for a sold MDF location in the Portuguese model approach to 500.000 €.

5.4.2.2 Model scenario results

For Portugal we consider all three broadband access architectures of this study, i.e. VDSL, PON and P2P. An overview of the results of the critical market shares in each cluster is provided in Table 32 to Table 34.

According to our results in Table 32, Portugal Telecom could profitably roll out a VDSL network up to the less urban cluster or for 39% of the broadband customer base. Up to these clusters only a moderate market share (below 13%) is needed. This reflects the

163 Our assumption of a higher than 80 % broadband penetration rate is based on the following arguments. Unlike in other countries we assume a higher percentage of business customers in Portugal (20% instead of 10% of the residential customers). In Portugal the higher rate of business customers is in particular due to many very small enterprises for which we assume that they become broadband customers at least in the medium term.

large scale effect of having relatively high numbers of subscribers per street cabinet in these areas. In spite of having a major share of homes connected per aerial cabling, the rural areas do not become profitable at all. This reflects the low number of subscribers per street cabinet in the rural areas.

The higher critical market shares needed for a first mover being not the incumbent reflect the more disadvantageous cost structure and the fact of not having extraordinary income from dismantling MDF locations¹⁶⁴.

164 One might discuss if a second mover VDSL solution will become market relevant if the incumbent does not roll out VDSL at all. We perceive it to be a strategic decision (e.g. competing with FTTC against FTTH), which is at least legally possible. We have therefore included the second mover VDSL case as in the other countries.

Table 32: Critical market shares under different market and regulatory scenarios for rolling out VDSL in Portugal¹⁶⁵

VDSL - P										
Cases	First Mover Cases			Second Mover Cases						
	Accumulated Customer Base	Stand Alone	Incumbent	80% Infrastructure Sharing	80% Dark Fibre and Infrastructure Sharing	80% Dark Fibre and Infrastructure Sharing	20% Infrastructure Sharing	20% Dark Fibre and Infrastructure Sharing	20% Dark Fibre and Infrastructure Sharing	20% Dark Fibre
Dense Urban	0.9%	7%	5%	9%	9%	9%	10%	10%	10%	10%
Urban	3.7%	7%	5%	9%	9%	9%	10%	10%	10%	10%
Less Urban	19.2%	8%	5%	10%	9%	9%	10%	10%	10%	10%
Dense Suburban	22.8%	11%	7%	13%	13%	12%	16%	16%	16%	15%
Suburban	29.8%	15%	9%	16%	15%	14%	20%	20%	20%	20%
Less Suburban	39.0%	24%	13%	24%	24%	18%	33%	33%	33%	31%
Dense Rural	63.4%	n.v.	n.v.	n.v.	n.v.	65%	n.v.	n.v.	n.v.	n.v.
Rural	100.0%	n.v.	n.v.	n.v.	n.v.	n.v.	n.v.	n.v.	n.v.	n.v.

n.v. = Not viable
Source: WIK-C

¹⁶⁵ The percentage values in the table indicate the critical market shares for profitability, i.e. the revenue – cost break even.

The second mover VDSL case with 80% dark fibre sharing is still viable in the dense rural cluster while the respective case of the incumbent is not viable. This model result is caused because renting a few fibres in the backhaul segment (second mover) is much cheaper than constructing own ducts (incumbent)¹⁶⁶. If the incumbent does not lease fibres in this cluster to competitors because it does not have any (does not construct fibre infrastructure because of no viability), the second mover of course cannot rent it, and then the cluster is not viable for the second mover either.

On the basis of duct access, alternative operators could profitably roll out VDSL to the same clusters, but need a higher critical market share of up to 35% in those clusters. Thus the VDSL roll-out for second movers seems to be replicable. However, one has to keep in mind the relatively high market shares of cable and mobile operators (mobile-only).

Table 33 summarises the model results if the operators roll out FTTH-PON in Portugal. A profitable roll-out for the incumbent is possible only for the urban clusters. In the dense suburban and suburban clusters the critical market shares are 70 and 85%, respectively. Due to the high market shares of cable and mobile-only, we assume that these market shares in reality are not achievable, thus, the cases in these areas are not profitable.

¹⁶⁶ The difference is a factor of 3.

Table 33: Critical market shares under different market and regulatory scenarios for rolling out FTTH-PON in Portugal¹⁶⁷

PON - P										
Cases	First Mover Cases		Second Mover Cases							
	Stand Alone	Incumbent	80% Infrastructure Sharing	20% Infrastructure Sharing	SLU + 80% Dark Fibre and Infrastructure Sharing	SLU + 80% Dark Fibre and Infrastructure Sharing	SLU + 80% Dark Fibre and Infrastructure Sharing	SLU + 20% Dark Fibre and Infrastructure Sharing	SLU + 20% Dark Fibre and Infrastructure Sharing	
Cluster	Accumulated Customer Base									
Dense Urban	0.9%	31%	28%	37%	36%	2%	4%	4%	4%	4%
Urban	3.7%	37%	35%	45%	44%	2%	4%	3%	3%	3%
Less Urban	19.2%	58%	54%	70%	68%	3%	4%	4%	5%	5%
Dense Suburban	22.8%	74%	70%	84%	84%	6%	12%	9%	11%	11%
Suburban	29.8%	91%	85%	n.v.	n.v.	8%	19%	15%	18%	18%
Less Suburban	39.0%	n.v.	n.v.	n.v.	n.v.	18%	32%	30%	34%	34%
Dense Rural	63.4%	n.v.	n.v.	n.v.	n.v.	n.v.	n.v.	n.v.	n.v.	n.v.
Rural	100.0%	n.v.	n.v.	n.v.	n.v.	n.v.	n.v.	n.v.	n.v.	n.v.

n.v. = Not viable
Source: WIK-C

¹⁶⁷ The percentage values in the table indicate the critical market shares for profitability, i.e. the revenue – cost break even. The reason why the 20% infrastructure sharing is more advantageous than the 80% infrastructure sharing is explained at the end of this section.

Even on the basis of duct access, the profitability of rolling out a second PON infrastructure is less profitable and is limited for a second mover to the dense urban and urban clusters with critical market shares of 37 and 45%, respectively (case 80% duct access). Basis for this assertion is our assessment that critical market shares above 60% do not result in a profitable business in a specific area due to the intensive intermodal competition by cable and due to mobile-only customers.

The potential for competition increases significantly if there is no need for duplicating inhouse and sub-loop cables for the second movers. If fibre sub-loop from the splitter location is available, the second mover only needs to rent the customer access lines required to connect the active customers. The critical market shares fall down below 34% in the worst case and in many clusters they are even below 10% for the alternative operators. Under these circumstances, viable competition seems to be a relevant market outcome because several operators have the chance to replicate the incumbent's PON roll-out. This result holds for all clusters where a first mover can roll out a PON network profitably.

The results for a FTTH P2P architecture are described in Table 34. A profitable roll-out for the incumbent would be limited to the 3 urban clusters or to 19.2% of the customer base. In the dense suburban cluster the incumbent would need a critical market share of 82%, which we qualify not to be achievable under the specific Portuguese intermodal competition conditions.

Table 34: Critical market shares under different market and regulatory scenarios for rolling out FTTH-P2P in Portugal¹⁶⁸

P2P - P					
Cases		First Mover Cases		Second Mover Cases	
Cluster	Accumulated Customer Base	Stand Alone	Incumbent	80% Infrastructure Sharing	20% Infrastructure Sharing
Dense Urban	0.9%	33%	31%	44%	41%
Urban	3.7%	41%	38%	53%	50%
Less Urban	19.2%	65%	60%	84%	80%
Dense Suburban	22.8%	87%	82%	n.v.	n.v.
Suburban	29.8%	n.v.	n.v.	n.v.	n.v.
Less Suburban	39.0%	n.v.	n.v.	n.v.	n.v.
Dense Rural	63.4%	n.v.	n.v.	n.v.	n.v.
Rural	100.0%	n.v.	n.v.	n.v.	n.v.

n.v. = Not viable

Source: WIK-C

Alternative second mover operators, even with duct access, need higher critical market shares compared with the incumbent. They can roll out P2P in the first two clusters only, thus serving a customer base of 4.6% only. Even then, this requires a critical market share between 41 and 53%, i.e. it depends on the market share of the other operators whether a roll-out is replicable.

The use of existing ducts from the incumbent may be more expensive than the construction of own ducts, especially in cases where a major amount of ducts is needed in parallel, like it happens in the backhaul segment of a P2P architecture. This is due to the fact that the incumbent's duct prices are calculated as average cost values per cluster, not considering the amount of parallel ducts of an individual link or, more general, of a access network segment. Our results reveal such a situation in which the 20% infrastructure using second mover has a slightly minor critical market share than

¹⁶⁸ The percentage values in the table indicate the critical market shares for profitability, i.e. the revenue – cost break even.

the 80% infrastructure sharing operator. Thus, the decision to use existing infrastructure or construct by itself has to be done in an individual link per link manner. Having this option would enable a cost efficient construction of an alternative NGA network.

5.4.2.3 Summary of results

Figure 46 and Figure 47 below describe the roll-out conditions for the various NGA technologies in Portugal. While Figure 46 describes the roll-out conditions of an incumbent, Figure 47 describes the results for an alternative operator under the optimistic assumption of infrastructure sharing, where we assume that, with effective regulation, 80% of the cables needed can use already existing infrastructure (ducts and/or poles for aerial cabling) of the incumbent.

Figure 46: NGA roll-out opportunities of the incumbent by technology in Portugal

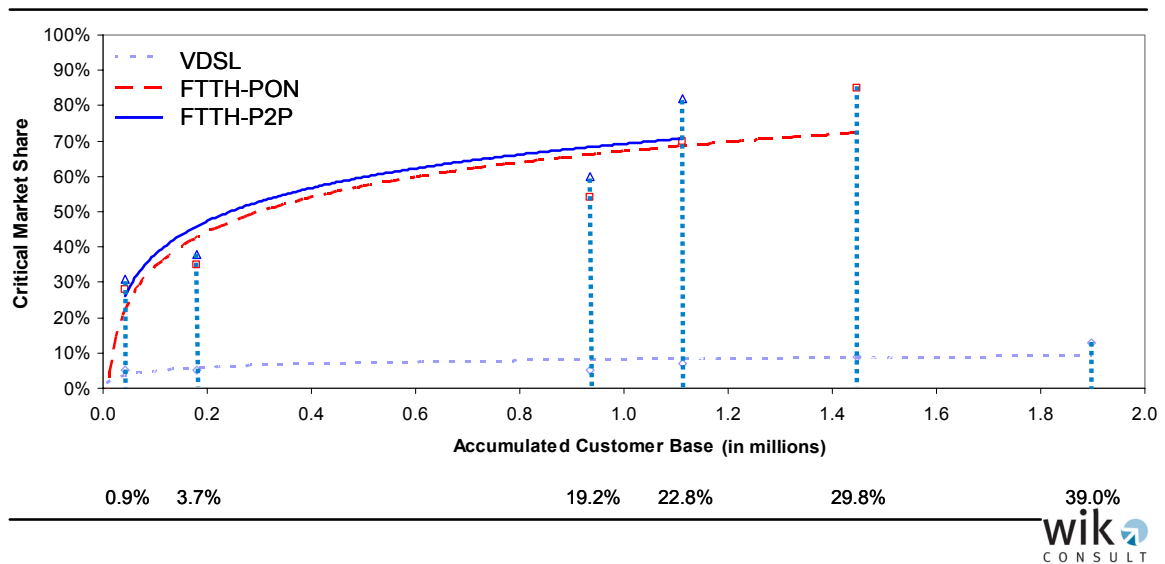

Source: WIK-C

Figure 47: NGA roll-out opportunities of an alternative operator in case of 80% infrastructure sharing in Portugal

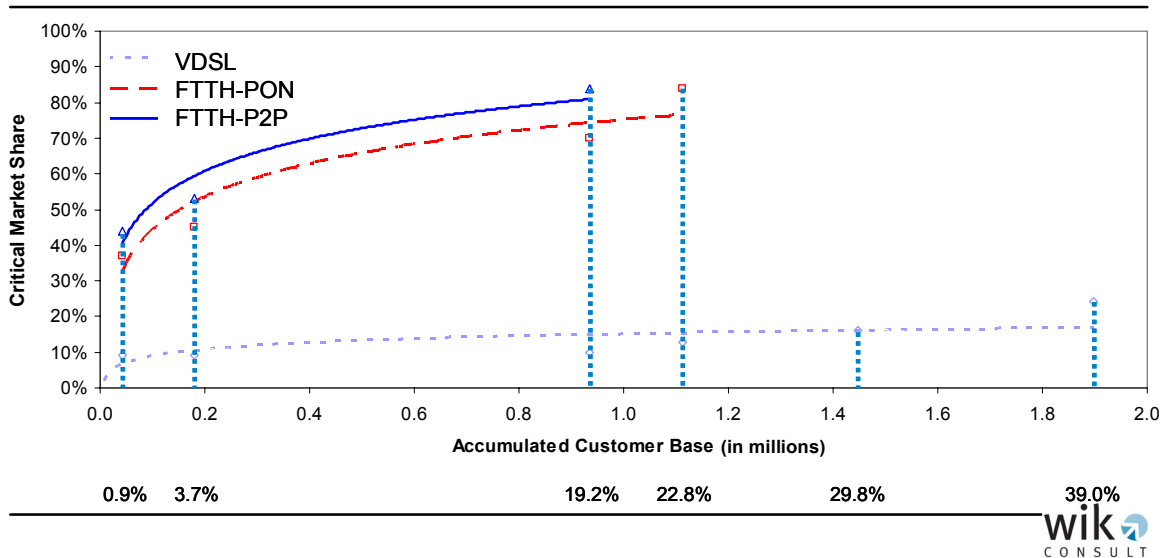

Source: WIK-C

The main results for Portugal are the following:

- (1) Due to the high amount of sub-loop lines in the street cabinets of the urban and suburban areas, the use of VDSL as a NGA access technology should be considered carefully due to possible heat dissemination problems.
- (2) A profitable VDSL roll-out is limited to 39% of the potential customer base.
- (3) A profitable FTTH roll-out is limited to 19.2% of the potential customer base. It may even be further limited if one takes into account the effects of intermodal competition from cable operators.
- (4) The FTTH architectures need higher investments and costs compared to VDSL.
- (5) The P2P architecture is characterised by higher investments and costs compared to the PON architecture in all cases and scenarios.
- (6) Alternative operators can roll out FTTC/ FTTH to a lesser degree than the incumbent even under optimistic infrastructure sharing assumptions.
- (7) Replicability of VDSL is given for some operators in the urban and part of the suburban clusters.
- (8) Replicability of FTTH is, if at all, limited to one alternative operator.

- (9) Fibre LLU in case of P2P and fibre SLU in case of PON increases replicability significantly and enables viable competition in all clusters where a first mover can profitably roll out the FTTH infrastructure.
- (10) The FTTH cases for second movers show that the mix of dark fibre, shared infrastructure, and self constructed infrastructure may yield economically better solutions than the pure use of shared infrastructure (e.g. empty ducts). This is due to the utilisation of fibres or subducts and the fact that the use of own cables may be cheaper than the rental of single fibres. The construction of own ducts may be cheaper than the rental of subducts (e.g. in the case of many parallel subducts needed in the backhaul segment of a P2P architecture). Thus, regulation should provide the choice between different wholesale service options to improve replicability.

5.4.2.4 Incumbent as infrastructure wholesale provider

All regulatory means that we consider in our model cases assume the incumbent to lease infrastructure to the second movers as a wholesale business, efficiently (80%) or less efficiently (20% infrastructure sharing). This will result in additional revenues for the incumbent which are not yet considered in our model results and which are caused by the incumbents decision to roll out a NGA infrastructure which can be leased to competitors as well.

This wholesale business may reduce the incumbent's risk to invest in the NGA business because the additional wholesale revenues help to reduce its critical retail market share for profitability. This is also an important consideration from a competition perspective since it shows that through wholesale access, the very high market shares that an incumbent would otherwise need to justify an NGA investment can be reduced to shares more compatible with an effectively competitive retail market whilst also enabling entry. With a wholesale infrastructure business the incumbent may support its financing of the infrastructure to connect 100% of homes at least in the viable clusters, thus lowering the critical market share for his retail business. In the clusters not being viable for the incumbent, i.e. those requiring a critical market share above 80%, a wholesale business cannot improve the viability, because there the incumbent will not roll out infrastructure at all.

In this section we consider at the example of the Portuguese incumbent the changes to the critical market share resulting from wholesale revenues of infrastructure leased to second movers.

Table 35: Critical market shares for the VDSL incumbent case with infrastructure wholesale revenues in Portugal¹⁶⁹

VDSL - P			
Cases		First Mover Cases	Sensitivities
Cluster	Accumulated Customer Base	VDSL Incumbent Base Scenario	VDSL incumbent + wholesale revenues from 2nd mover VDSL 80% infrastructure sharing *)
Dense Urban	0.9%	5%	5%
Urban	3.7%	5%	5%
Less Urban	19.2%	5%	4%
Dense Suburban	22.8%	7%	7%
Suburban	29.8%	9%	8%
Less Suburban	39.0%	13%	10%
Dense Rural	63.4%	n.v.	n.v.
Rural	100.0%	n.v.	n.v.

n.v. = Not viable

*) Incumbent and 2nd mover share the street cabinet.

Source: WIK-C

First, we consider the incumbent to roll out VDSL and compare the respective results for the critical market share with the results of the critical market share in a modified case with additional wholesale income for the incumbent from a second mover VDSL operator: The infrastructure rental fees of a VDSL second mover renting 80% of the infrastructure (backhaul and feeder segments) from the incumbent are added to the revenue of the incumbent¹⁷⁰ cluster per cluster. Since the infrastructure rental may depend on the market share a second mover will achieve we take the rental fees of the second mover at its critical market share¹⁷¹. The results of this approach are described

¹⁶⁹ The percentage values in the table indicate the critical market shares for profitability, i.e. the revenue – cost break even.

¹⁷⁰ Since the copper distribution (access) network in our model is considered as SLU line rental (for incumbent and second mover), we do not consider the SLU line rental as additional revenue, because the rental of a copper SLU would cause revenues and costs at the same amount.

¹⁷¹ In fact there is no difference between the market shares below 20% because the infrastructure rented is invariant to the amount of customers up to the time the DSLAMS of the second mover have to be added by a second one – and even then there is only one additional fibre per street cabinet needed.

in Table 35 and Figure 48. The incumbent case with additional wholesale revenues only shows a slight improvement in its critical market shares. This is due to the fact, that the second mover only purchases a relatively small amount of wholesale services from the incumbent because of its relatively low critical market shares. However, adding additional entrants would increase the effect.

Figure 48: Critical market shares for the VDSL incumbent case with infrastructure wholesale income in Portugal

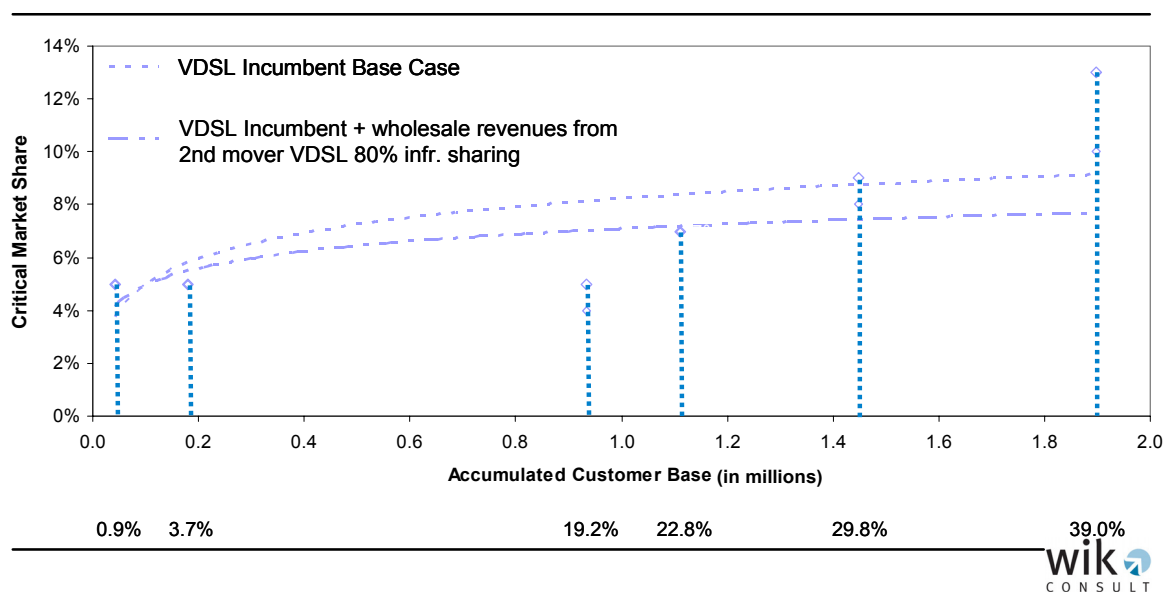

Source: WIK-C

Second, we consider the incumbent to roll out PON. The second mover is assumed to roll out PON with 80% infrastructure sharing down to the distribution segment, or it uses SLU at the distribution network instead, or it is rolling out a P2P architecture renting 80% of the infrastructure needed from the incumbent. All of the second mover rental fees, now including the fibre SLU rental fees as well, are considered as additional wholesale revenues for the appropriately modified cases and to the extent needed for the critical market shares of the second mover cases, except the second mover PON SLU case, where we assume 20% market share of the second mover¹⁷². The results of this model specification are described in Table 36 and Figure 49.

¹⁷² The critical market shares for the case PON 80% infrastructure sharing with SLU in Portugal are between 2% and 8% in the clusters dense urban to suburban.

Table 36: Critical market shares for the PON incumbent case with additional wholesale revenues in Portugal

PON - P			
Cases	First Mover Cases	Sensitivities	
Cluster	Accumulated Customer Base	PON incumbent + wholesale revenues from 2nd mover PON Infrastructure Sharing	PON incumbent + wholesale revenues from 2nd mover P2P Infrastructure Sharing*)
Dense Urban	0.9%	10%	8%
Urban	3.7%	11%	10%
Less Urban	19.2%	15%	13%
Dense Suburban	22.8%	27%	70%
Suburban	29.8%	85%	85%
Less Suburban	39.0%	n.v.	n.v.
Dense Rural	63.4%	n.v.	n.v.
Rural	100.0%	n.v.	n.v.

n.v. = Not viable

*) Invest in OSDF is considered

The wholesale revenues in the medium right column assume a market share of 20% for the PON SLU second mover

Source: WIK-C

Figure 49: Critical market shares in the PON incumbent case with infrastructure wholesale income in Portugal

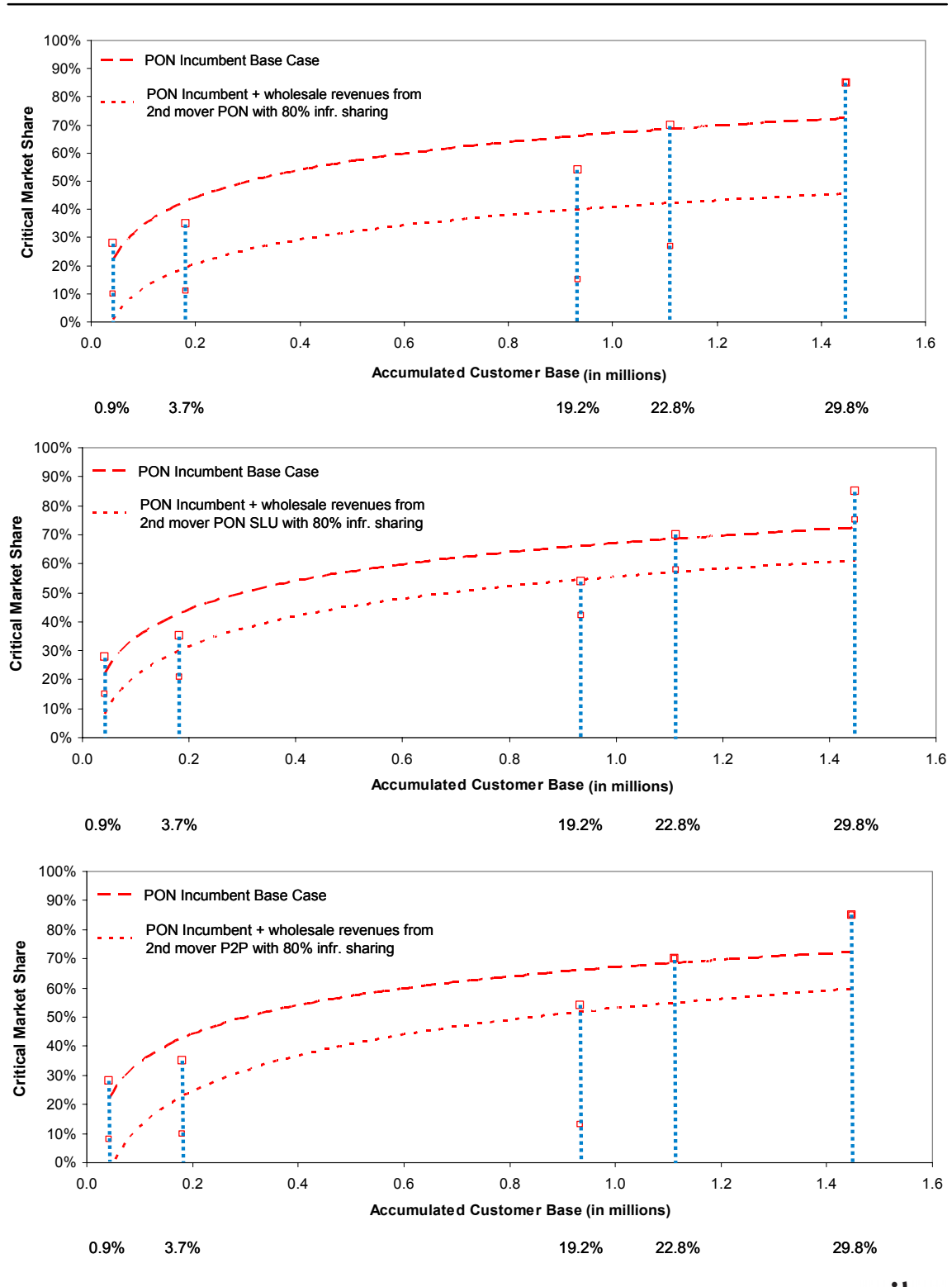

Source: WIK-C

The model assumes in the PON and P2P cases the second movers to rent the access network infrastructure to install fibre to all homes or the complete customer base of a cluster. In effect, they rent a lot of infrastructure from the incumbent, thus, increasing the incumbent's profitability (or reducing the critical market share). However, it is interesting to note that in this market structure the duct renting entrant would itself require a substantial share for profitability (rising from 37% in dense urban to 70% in less urban). Adding the shares of the incumbent and entrant suggests that wholesaling duct access would only be viable (total market share of incumbent plus duct renting entrant <85%) in urban areas and would tend to result in a concentrated market structure perhaps with the incumbent and one equally strong entrant as the only major players in the market (there would be little further room in this structure for cable).

In the PON SLU cases the second mover rents infrastructure to a lesser extent. It only rents as many fibres in the distribution segments as it actually needs to connect its existing customers. Thus, there is a lower reduction in the critical market share. However, the advantage would be increased with each additional entrant. This market structure could support the incumbent and a number of competitors.¹⁷³

Third, we consider an incumbent P2P case with additional revenues from a second mover P2P operator who rents fibre LLU as access network infrastructure. Since in these cases our model results in low critical market shares for the second movers we here assumed for those a received market share of 5% and 20%, respectively. The results are described in Table 37 and Figure 50. A higher market share of the second mover lowers the critical market share of the incumbent, but not to the same absolute amount. Again a number of competitors could be supported in this market structure, whilst adding an additional LLU competitor would further lower the incumbents' critical retail market share.

173 The incumbent might prefer the duct rental case because it would promote a duopoly, and even a monopoly if the second mover fails. Furthermore, the rental of ducts for a second mover bears a higher risk to achieve the (higher) critical market share compared to fibre LLU/ SLU.

Table 37: Critical market shares of the P2P incumbent case with additional wholesale LLU revenues in Portugal

P2P - P				
Cases		First Mover Cases	Sensitivities	
Cluster	Accumulated Customer Base	P2P Incumbent Base Scenario	P2P incumbent + wholesale revenues from 2nd mover P2P LLU (5% market share)	P2P incumbent + wholesale revenues from 2nd mover P2P LLU (20% market share)
Dense Urban	0.9%	31%	28%	18%
Urban	3.7%	38%	35%	26%
Less Urban	19.2%	60%	57%	48%
Dense Suburb	22.8%	82%	79%	69%
Suburban	29.8%	n.v.	n.v.	n.v.
Less Suburban	39.0%	n.v.	n.v.	n.v.
Dense Rural	63.4%	n.v.	n.v.	n.v.
Rural	100.0%	n.v.	n.v.	n.v.

n.v. = Not viable

Source: WIK-C

Figure 50: Critical market shares for the P2P incumbent case with additional wholesale fibre LLU revenues in Portugal

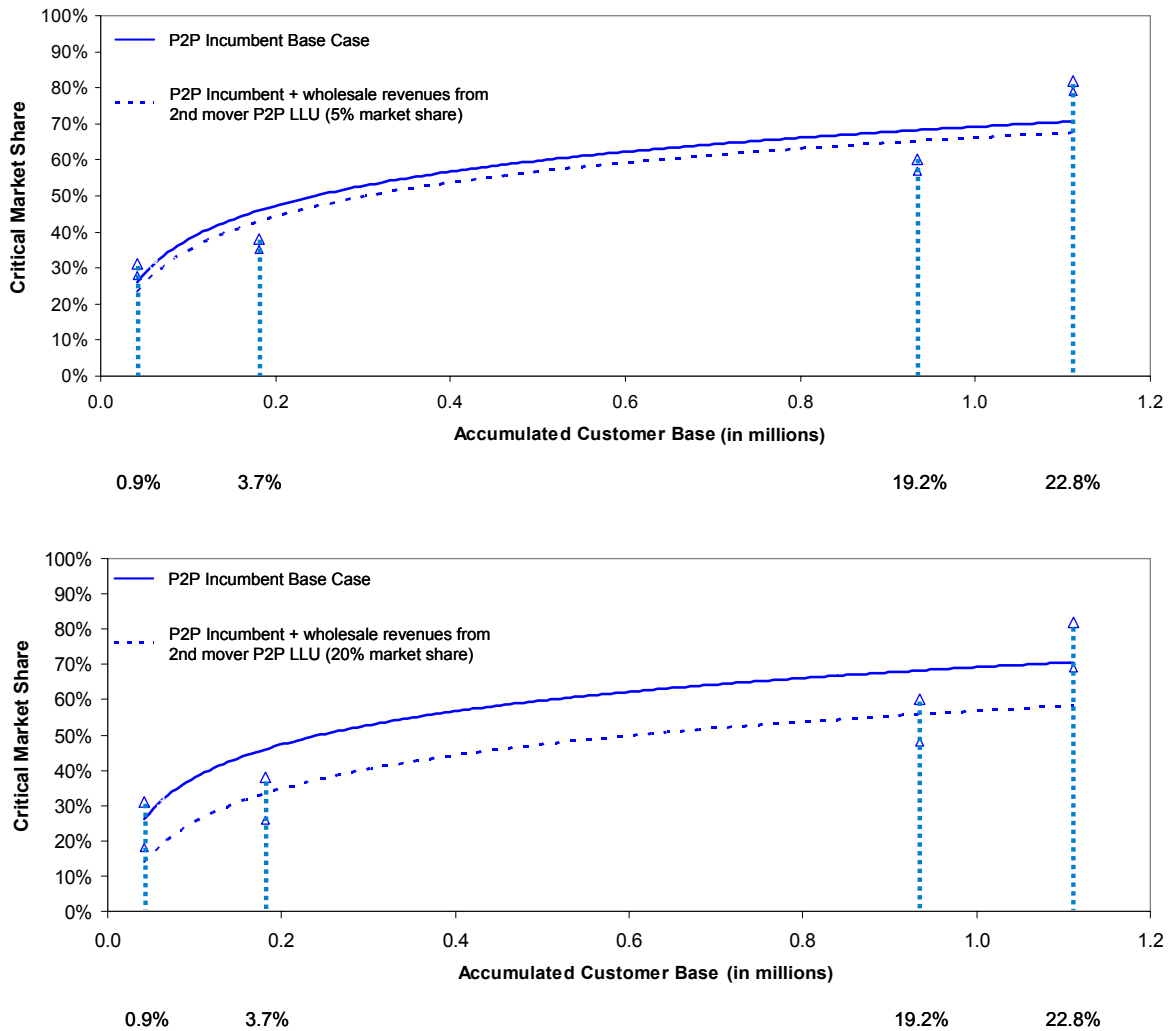

Source: WIK-C

Summarizing the results of this section we can state that the additional revenues an incumbent achieves by wholesaling its NGA infrastructure reduces its critical market share for a profitable NGA business significantly, even in the fibre LLU and SLU business. On the other hand, as already shown in all country results, renting of already existing duct infrastructure and fibre for a fair price improves the viability for the second movers to a certain extent, but still requires very high market shares. Renting Fibre SLU (or fibre LLU), however, introduces and improves replicability to a major extent, and can result in outcomes compatible with effective competition.

5.5 Spain

5.5.1 Market developments and regulatory background

5.5.1.1 Strategic positioning of the main players in the broadband market

Background

In Spain there are about 7,650 MDFs. Information about the number of street cabinets as well as on the average sub-loop length is not publicly available.

According to the European Commission's 13th Implementation Report, Telefonica has a market share of 74.2 % regarding the fixed telephony market (by retail revenue) and a market share of 56.1 % in the retail market of fixed broadband access lines (comprising DSL, cable, FTTB/H, satellite, powerline communications and other technologies).

Telefonica

In 2007 and in 2008 Telefonica has been working on two field trials with a FTTN/VDSL2 and a FTTH/GPON network, respectively.

In March 2008 Telefonica informed the CMT about its intention of offering a FTTH/GPON pre-commercial service that will last from March 31, 2008 until September 30, 2008. Telefonica notified CMT that it will soon pass 200k homes with GPON in 12 cities, and will pass 3 million homes with GPON by end-2010. Among the services that will be offered, there are double play and triple play offers with speeds of up to 30 Mbps. It seems that Telefonica could be in a position to offer retail services based on its new FTTH/GPON networks in October 2008.¹⁷⁴

Up until now Telefonica is the only operator in Spain which has made public deployment plans regarding FTTC/VDSL and FTTB/H. It seems that Telefonica is following an FTTB/H rather than a VDSL approach in cities. However, Telefonica has also requested modifications to the metallic loop spectrum plans, to facilitate VDSL from both the MDF and from remote nodes. The latter, called MUXFINs (the acronym stands for (in Spanish) "**M**ultiple**X**or **F**lexible de **I**nterfaces **N**ormalizadas") are used by Telefonica to offer retail broadband services. These remote nodes are connected to the core network

¹⁷⁴ Telefonica has announced to launch a commercial fibre-optic broadband internet access network by 31 October, 2008. The announcement in addition specifies that direct fibre access (FTTx) at speeds of up to 30Mbps will initially be restricted to selected areas of major cities including Madrid and Barcelona, where it has already rolled out the network. Moreover, it is reported that an FTTx network with national scope will cost Telefonica an estimated EUR 1 billion to complete. See TeleGeography Comms Update, September 5, 2008.

through optic fiber and to the end user premises through copper cable. MUXFINs are located inside buildings rather than in street cabinets.

Ono

In May 2008 the cable network operator Ono announced that it will launch a broadband internet pilot in the metropolitan area of Valladolid. Based on the Docsis 3.0 technology, Ono aims to provide high speed connections of up to 100 Mbps. The operator plans to test this technology for six months before the service's commercial launch in Madrid, Valencia and Barcelona, scheduled for the last quarter of 2008.¹⁷⁵ The planned investment sum is EUR 75 mill. The network upgrade is to be completed in 2009.

Up until today, there is no specific retail price information announced by ONO. Currently, the 25Mbps offered by ONO costs 75 Euros per month. The Spanish newspaper "El Pais" published in June 2008 that in general terms in Spain the 100Mbps access would cost 100 Euros.

5.5.1.2 Regulation, wholesale services

General principles of regulation of Next Generation Access Networks

In May 2007 the CMT launched a public consultation on Next Generation Access Networks. The following issues were addressed in the consultation:

- deployment scenarios for the new access networks (VDSL, FTTN + VDSL, FTTB + VDSL, FTTH, cable networks, wireless networks WiMAX and 3G HSDPA);
- market review;
- civil works and deployment inside the buildings and
- digital divide.

The public consultation ended in June 2007.

In January 2008 the CMT published a document in which it laid out the principles and main guidelines of the future regulation of the next generation access networks (NGA), see CMT (2008). This document defines the principles that will inspire the specific regulatory measures regarding NGAN and it also provides a summary of the responses to the aforementioned public consultation.

¹⁷⁵ Ono just recently has announced that they will begin to offer Internet access services of 100Mbps/5Mbps and 50Mbps/3Mbps at the end of September 2008. The offer will be available in Madrid through 10 nodes which will be activated in a progressive way during the last 3 months of 2008.

Provisional measures adopted by CMT in May 2008

Recently, in May 2008, the CMT approved a set of provisional measures aimed at promoting the deployment of FTTH by alternative operators. According to Rodriguez (2008) CMT has considered the immediate imposition of interim measures on Telefonica to be essential because of:

- Telefonica's urgent plans and expected schedule to launch commercial FTTH services,
- the importance of allowing third operators to plan in advance the deployment of investment strategies,
- the necessity that early wholesale services exist that allow operators to develop competing offers, thus, making progress on the investment ladder.

The provisional measures focus on

- access to ducts and cabinets and
- virtual loop access in NGAN conveyance nodes.

The remedies imposed on Telefonica will be in force until CMT completes the definition of markets 4 and 5.

Regarding access to ducts and cabinets the main obligations imposed are (see Rodriguez (2008)):

- to meet reasonable requests for access to infrastructure elements (ducts, manholes, etc.),
- cost-oriented prices,
- non-discrimination, i.e. equal treatment of operators regarding access and with respect to offering services and access information on conditions not worse than applied internally.

Moreover, transparency regarding access conditions is required; this refers to the provision of information about infrastructures required by operators to design their access requests, in particular:

- the list of FTTH/GPON nodes to be deployed until 2010, together with their respective service area and the date when they will be operative (one month after the interim measures are in force),

- adequate information about infrastructures: space availability in those ducts and manholes where Telefonica expects to deploy FTTH in the next 14 months (two months after the interim measures are in force),
- adequate information about the affected infrastructures: space availability in ducts and manholes (one year in advance to every fibre deployment).

Telefonica has to come to an agreement within a period of 4 months after initiation of negotiations. In case an agreement cannot be reached the regulator will step in, and it has to approve a resolution four months after its intervention is requested. For the definition of the economic conditions of the agreement the regulator can take into account the agreements about infrastructure sharing that already exist between Telefonica and other operators, as well as resolutions about this type of conflicts that were approved by the CMT.

Regarding virtual loop access the following was specified. In NGN exchanges where an operator has required access to its associated infrastructure, Telefonica shall offer a wholesale service called FTTH/GPON virtual loop (bucle virtual FTTH/GPON) subject to the following obligations (see Rodriguez (2008)):

- Meeting reasonable requests, ensuring technical replicability of the FTTH network functionalities, thus allowing the provision of equivalent retail services (available in four months after interim measures are in force);
- Reasonable prices, avoiding margin squeeze practices;
- Non-discrimination, consisting in equal treatment of operators regarding access and regarding the offering of services and access information on conditions not worse than applied internally;
- Transparency in access conditions, i.e. the provision of information that allows operators to efficiently request wholesale services. This relates on the one hand to estimates of the expected coverage achieved by the NGN exchanges (e.g. homes passed); this must be updated monthly. On the other hand information has to be provided regarding the buildings connected by FTTH to every NGN exchange; this information must be updated daily.

Overall, it is worth noting that the provisional measures apparently do not envisage any medium term access to Telefonica's fibre-based infrastructure (no fibre unbundling has been imposed so far in Spain). Moreover, the requirement for virtual loop access was dependent on a commitment by the receiving operator to use duct access from Telefonica to build their own infrastructure.

On 31 July 2008, the CMT revised the provisional measures of 8 May 2008 following the appeals filed by Telefonica and by other operators. The obligation on Telefonica to

provide 'virtual GPON/FTTH loop access' was removed, on the grounds that this 'secondary remedy' was no longer necessary given that the 'primary remedy' (civil infrastructure access) will be operational by 16 September 2008 (the CMT decision relies in this respect on statements made by Telefonica in a letter dated 28 July 2008, which is summarised in the CMT decision of 31 July 2008). On the same date, CMT also approved regulatory principles relating to remote node deployment. To be more precise, the CMT states that the obligation imposed on Telefonica of offering access to its civil works infrastructure embraces also the spaces, channels, chambers and ducts that Telefonica has in the areas where the retail broadband service is provided through the remote nodes.¹⁷⁶

5.5.2 Model results

5.5.2.1 Country specific assumptions

The total potential customer base in Spain amounts to 26.1 million customers. 23.73 million of these are residential customers (households) and 2.37 million are business customers. Like in all other countries these numbers are inflated by broadband customers using cable modems for internet access, mobile-only households and those not using electronic communication services at all.

Comparing Spain with the other five countries considered in this study cable has a relatively strong role in the national broadband market (No. 2 of the six countries). Already 20% of all broadband customers are currently served by the cable operators. As already mentioned in the section above the cable operator ONO has announced to invest nationwide in broadband Internet access in the near future and thus improves its competitive position.

In Spain there also is a medium strong penetration of mobile-only users, being 16%¹⁷⁷.

These aspects imply the conclusion that fixed-line operators might not be able to address the total broadband customer base, rather only 70 – 80 % of it due to the fact that there is at least some intermodal competition.

In Spain the potential customer base (Table 38) living in dense populated areas is higher (1.7%) compared to Germany (0.2%), but lower compared to France (2.6%). 12.2% of the population live in the three urban clusters (dense urban, urban, less

¹⁷⁶ CMT press release August 1, 2008: "La CMT da luz verde a la fibra de Telefónica con la condición de que ésta abra sus canalizaciones".

¹⁷⁷ See EU Commission (2008).

urban), and with ~ 70% a high share of it is living in rural areas. Thus, Spain is a country with comparable sized urban and suburban areas and a strong rural area.

Table 38: Spatial distribution of the customer base in Spain

Spain			
Cluster Type	Customer base		
	in mill.	in %	accumulated %
Dense Urban	0.4	1.7	1.7
Urban	0.7	2.8	4.5
Less Urban	2.1	7.7	12.2
Dense Suburban	1.1	4.3	16.5
Suburban	3.4	13.1	29.6
Less Suburban	0.1	0.2	29.8
Dense Rural	9.8	37.6	67.4
Rural	8.5	32.6	100.0
Total	26.1	100.0	

Source: WIK-C

Table 39 shows parameters of the Spanish PSTN network. According to the number of MDF it is relatively decentralized, according to the number of street cabinets it is medium centralized, having approximately 10 street cabinets per MDF on average, which is comparable to France (9). The average sub-loop length is medium (~ 500 m) and should be analysed in more detail with regard to roll out VDSL. Remember that a sub-loop length above 500 m is already critical for the bandwidth transmittable.

Another technical problem might occur in "street cabinets" (MUXFINS) with high customer concentration, because the larger the number of VDSL customer ports the more heat has to be transported outside (by ventilators) or cooled down (by air condition). These difficulties may increase if the street distribution frames are located in manholes, because these may have to be enlarged for getting more space (additional digging and larger manholes) and the installation of air condition could cause higher additional cost. These facts have been reported by ECTA members. On the other hand, Telefonica announced to roll out VDSL beside GPON. Due to the fact that there are no published data about the details of the existing access network and VDSL roll-out we can only give a hint to possible technological problems but will consider VDSL as an architectural choice for the incumbent. Competitors face the same risks, but in addition do know little about the Telefonica VDSL roll-out and therefore lack a reliable base for own VDSL cases. Therefore we did not model a competitor's VDSL solution.

It is reported by ECTA that there exists an empty duct network being constructed in the late '90s being intended for broadband use in Spain, named FOTON¹⁷⁸. But there is no information about it publicly available, neither where it is nor to what extent (e.g. homes passed) it exists nor prices for its usage. Therefore we did not take this concrete infrastructure as existing empty ducts into account being usable already for a first mover, but our cases for second movers take duct rental into account to different degrees of usage¹⁷⁹.

Table 39: Structural parameters of the PSTN network in Spain

Structural parameter	Value
Total number of main distribution frames	~7.600
Total number of street cabinets	~74.000
Average sub-loop length (in metres)	~500

Source: WIK-C

We assume a further increase of broadband penetration to app. 82% in the Spanish market. Around 18% of all customers remain subscribers of a single play telephony service. Compared to France there is a remarkable difference between the ARPU for double and triple play services, thus while in France IP-TV at the moment is sold as a free add-on to double play, in Spain it is a recognizable additional service.

Table 40: Assumptions on average revenues per subscriber in Spain

Type of subscriber	Average revenue per subscriber (in €)	Share of the total customer base (in %)	Accumulated %
Single Play	20.0	18.2	18.2
Double Play	35.0	59.1	77.3
Triple Play	53.0	13.6	90.9
Business	55.0	9.1	100.0
Average Total	36.5	100.0	

Source: WIK-C

The weighted average of the ARPU used in the calculations of the model is assumed as 36.5 € per month and subscriber. This average is calculated out of the ARPUs for the different services and the share these services will be bought as deployed in Table 40.

¹⁷⁸ May be comparable to the Italian Socrate project (section 5.3.1.1).

¹⁷⁹ Therefore this infrastructure (and other existing ducts and fibres) is at least considered in the second mover cases.

For all scenarios we use a WACC of 10.0 %, which is our default value for the interest rate the regulatory authority uses to calculate ex ante regulated wholesale services and which is in line compared to other European countries.

It is worth to mention, that the use of aerial cabling in Spain is high and already starts in the suburban areas, which may decrease infrastructural cost. Due to the lower construction cost and the large amount of MDF sites in rural areas we reduced the average revenue received for a sold MDF location in Spain to 500,000 €.

5.5.2.2 Model scenario results

For Spain we consider all three subscriber broadband access architectures of this study, VDSL, PON and P2P in the case of the incumbent. For the competitive cases we only consider PON and P2P for the reasons described in section 5.5.2.1 above. An overview of the results of the critical market shares in each cluster gives Table 41 to Table 43.

According to our results in Table 41 Telefonica could profitably roll out a VDSL network up to the dense rural cluster or for ~ 67% of the broadband customer base. Up to the suburban cluster only a moderate market share (below 13%) is needed, above it (less suburban, dense rural) it is rising from 45 to 62%. This reflects the large scale effect of having relatively high numbers of subscribers per street cabinet in the first areas. In spite of having a major share of homes connected per aerial cabling the rural area does not get profitable at all. This reflects the distribution of many small MDFs in the rural cluster.

For an operator not being the incumbent and rolling out VDSL as a first mover one could expect higher critical market shares needed compared to the incumbent, as already shown for the other countries, reflecting the worse cost structure and the fact not having an extraordinary income from dismantling MDF locations. But due to the fact that there is no information base available for a reliable investment planning and considering the investment risks related to that, there is no competitor known planning to roll out VDSL, therefore we did not model this competitive case.

Table 41: Market and regulatory scenarios for rolling out VDSL in Spain

VDSL - ES		
Cases		First Mover Case
Cluster	Accumulated Customer Base	Incumbent
Dense Urban	1.7%	8%
Urban	4.5%	7%
Less Urban	12.2%	7%
Dense Suburban	16.5%	9%
Suburban	29.6%	11%
Less Suburban	29.8%	45%
Dense Rural	67.4%	62%
Rural	100.0%	n.v.

n.v. = Not viable

Source: WIK-C

Interpreting the results one has to keep in mind the relatively high market shares of cable and mobile operators (mobile-only).

Table 42 summarises the model results if the operators roll out FTTH-PON in Spain. A profitable roll-out for the incumbent is possible only for the urban clusters. In the dense suburban and suburban clusters the critical market shares are 79 and 98% respectively. Due to the high market shares of cable and mobile-only customers we assume these market shares already not to be achievable, thus the cases in these areas not to be profitable.

Table 42: Critical market shares under different market and regulatory scenarios for rolling out FTTH-PON in Spain¹⁸⁰

Cases		PON - ES									
		First Mover Cases		Second Mover Cases							
Cluster	Accumulated Customer Base	Stand Alone	Incumbent	80% Infrastructure Sharing	20% Infrastructure Sharing	80% Dark Fibre and Infrastructure Sharing	SLU + 80% Dark Fibre and Infrastructure Sharing	SLU + 80% Dark Fibre	SLU + 20% Dark Fibre and Infrastructure Sharing	SLU + 20% Dark Fibre	
Dense Urban	1.7%	38%	37%	44%	45%	8%	9%	9%	20%	20%	
Urban	4.5%	42%	41%	47%	48%	8%	9%	9%	19%	19%	
Less Urban	12.2%	54%	52%	60%	62%	8%	9%	9%	19%	19%	
Dense Suburban	16.5%	82%	79%	77%	n.v.	14%	21%	21%	29%	31%	
Suburban	29.6%	100%	98%	94%	n.v.	19%	24%	24%	38%	39%	
Less Suburban	29.8%	n.v.	n.v.	n.v.	n.v.	n.v.	n.v.	n.v.	n.v.	n.v.	
Dense Rural	67.4%	n.v.	n.v.	n.v.	n.v.	n.v.	n.v.	n.v.	n.v.	n.v.	
Rural	100.0%	n.v.	n.v.	n.v.	n.v.	n.v.	n.v.	n.v.	n.v.	n.v.	

n.v. = Not viable
Source: WIK-C

¹⁸⁰ The percentage values in the table indicate the critical market shares for profitability, i.e. the revenue – cost break even.

Even on the basis of duct access, the profitability of rolling out a second PON infrastructure is less profitable and is, if at all, limited for a second mover to the dense urban and urban clusters with critical market shares of 44 and 47% respectively (case 80% duct). These are shares for the second mover, thus the first mover already has market shares. Basis for this assertion is our assessment that critical market shares above 70 - 80% do not result in a profitable business case in a specific area due to the intensive intermodal competition by cable and due to mobile-only customers.

The potential for competition increases significantly if there is no need for duplicating inhouse and sub-loop cables for the second movers. If fibre sub-loops from the splitter location are available, the second mover only needs to rent the customer access lines required to connect the active customers. The critical market shares decrease below 39% in the worst case and in many clusters they are even below 10% for the alternative operators. Under these circumstances viable competition seems to be a relevant market outcome because several operators have the chance to replicate the incumbent's PON roll-out. This results hold for all clusters where a first mover can roll out a PON network profitably.

Table 43 describes the results for a FTTH P2P architecture. A profitable roll-out for the incumbent would be limited to the 3 urban clusters or to 12.2% of the customer base. In the dense suburban cluster the incumbent would need a critical market share of 94%, which we qualify not to be achievable under the specific Spanish intermodal competition conditions.

Table 43: Critical market shares under different market and regulatory scenarios for rolling out FTTH-P2P in Spain¹⁸¹

P2P - ES					
Cases		First Mover Cases		Second Mover Cases	
Cluster	Accumulated Customer Base	Stand Alone	Incumbent	80% Infrastructure Sharing	20% Infrastructure Sharing
Dense Urban	1.7%	42%	41%	57%	53%
Urban	4.5%	47%	46%	61%	57%
Less Urban	12.2%	61%	59%	76%	75%
Dense Suburban	16.5%	98%	94%	n.v.	n.v.
Suburban	29.6%	n.v.	n.v.	n.v.	n.v.
Less Suburban	29.8%	n.v.	n.v.	n.v.	n.v.
Dense Rural	67.4%	n.v.	n.v.	n.v.	n.v.
Rural	100.0%	n.v.	n.v.	n.v.	n.v.

n.v. = Not viable

Source: WIK-C

Alternative second mover operators even with duct access need higher critical market shares compared with the incumbent and can roll out P2P in the first two clusters only, thus serving a customer base of 4.5% only. But requiring a critical market share between 53 and 57% it is already very unlikely that a roll-out is replicable (depending on the market share of the other operators (incumbent, cable, mobile-only)).

5.5.2.3 Summary of results

Figure 51 and Figure 52 below describe the roll-out conditions for the various NGA technologies in Spain. While Figure 51 describes the roll-out conditions of an incumbent, Figure 52 describes the results for an alternative operator under the optimistic assumption of infrastructure sharing, where we assume that with effective

¹⁸¹ The percentage values in the table indicate the critical market shares for profitability, i.e. the revenue – cost break even.

regulation 80% of the cables needed can use already existing infrastructure (ducts and/or poles for aerial cabling) of the incumbent.

Figure 51: NGA roll-out opportunities of the incumbent by technology in Spain

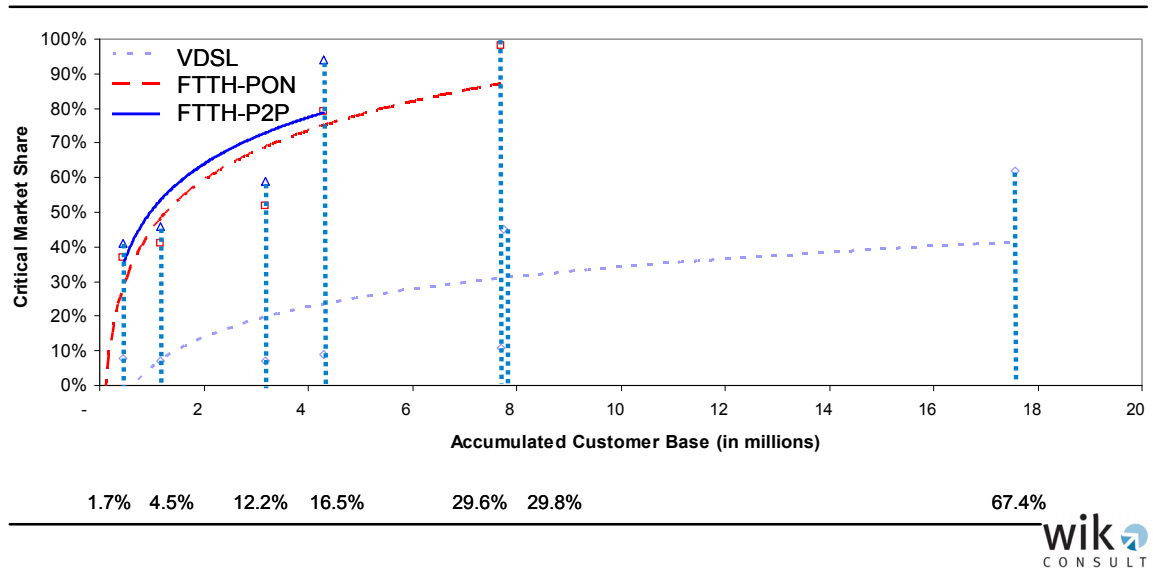

Source: WIK-C

Figure 52: NGA roll-out opportunities of an alternative operator in case of 80% infrastructure sharing in Spain

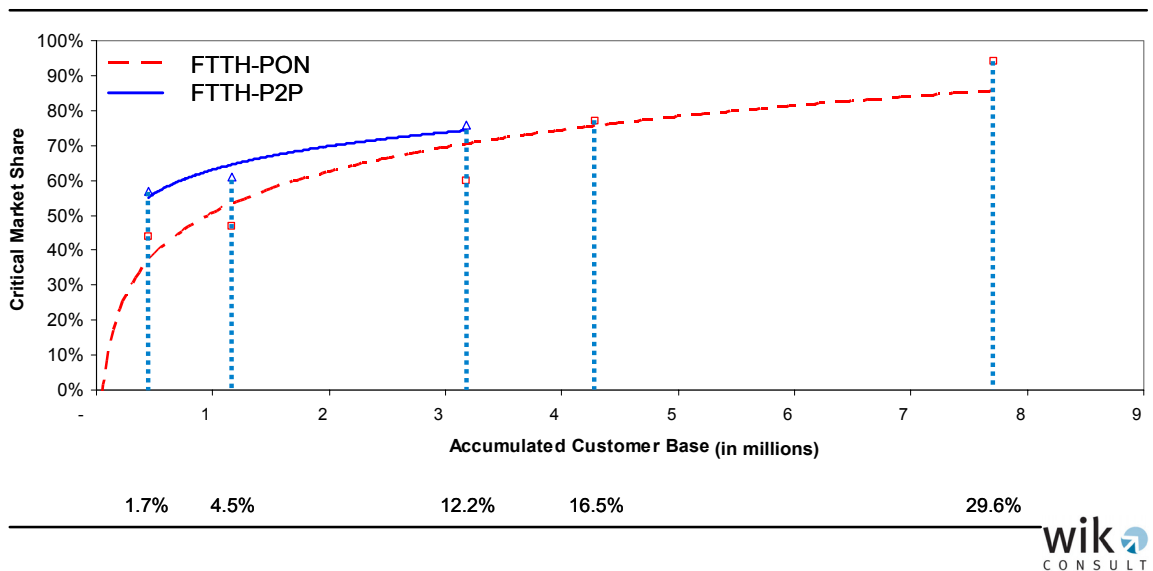

Source: WIK-C

For Spain the main results are:

- (1) Due to the underground construction of “street cabinets” and the relatively high amount of sub-loop lines in these concentrators of the urban and suburban areas the use of VDSL as a NGA access technology should be considered carefully due to possible heat dissemination problems and additional cost for digging.
- (2) A profitable VDSL roll-out for the incumbent might be limited to ~ 67% of the potential customer base.
- (3) A profitable FTTH roll-out is limited to 12.2% of the potential customer base.
- (4) The FTTH architectures need a higher investment and cause higher costs compared to VDSL.
- (5) The P2P architecture is characterised by higher investments compared to the PON architecture in all cases and scenarios.
- (6) Alternative operators can roll out FTTH to a lesser degree than the incumbent even under optimistic infrastructure sharing assumptions.
- (7) Replicability of FTTH is, if at all, limited to one alternative operator.
- (8) Fibre LLU in case of P2P and fibre SLU in case of PON increases replicability significantly and enables viable competition in the most clusters where a first mover rolls out the FTTH infrastructure. Replicability is not given in the clusters less suburban and below.

5.6 Sweden

5.6.1 Market developments and regulatory background

5.6.1.1 Strategic positioning of the main players in the broadband market

Background

In Sweden there are about 8,200 MDFs. Information about the number of street cabinets is not publicly available. The average sub-loop length is about 400 m.

Broadband penetration in Sweden mainly rests on xDSL (61 %). Cable TV accounts for 24 % and fibre LAN for 15 %¹⁸² of all broadband connections. A report from FTTH Council Europe stated that Sweden had 7 % FTTB/FTTH household penetration by mid-2007, the highest in Europe, with over 400,000 households enjoying access to a direct fibre connection by that date (TeleGeography March 14, 2008). As of end of 2006, around 35 % of all apartments in Multi Dwelling Units (MDUs) with FTTB/H potential have already been installed (Helgesson (2007)).

According to the European Commission's 13th Implementation Report, TeliaSonera has a market share of 56.0 % regarding the fixed telephony market (by retail revenue) and a market share of 37.5 % in the retail market for fixed broadband access lines (comprising DSL, cable, FTTB/H, satellite, powerline communications and other technologies).

There are three different business models in the market for electronic communications services in Sweden:

- Entities deploying and owning fibre; examples are municipal companies like Stokab in Stockholm (public company) and housing companies (often public companies) like Svenska Bostäder. These entities mainly focus on a carrier's carrier strategic approach.
- Network operators; examples are the incumbent TeliaSonera and the alternative telco B2 (now owned by Telenor). They deploy active equipment and connect to end users.
- Internet Service Providers, Application Service Providers.

TeliaSonera

Until very recently TeliaSonera had not initiated any major fibre access rollout in Sweden, rather, the focus was mostly on DSL technology to deliver the triple play services package.¹⁸³ In March 2008, however, TeliaSonera has announced plans to deploy a mixture of next-generation fixed broadband access technologies. Spread over a period of 5 years, the initiative is to involve between 1.5 to 2 mill. households and enterprises all over Sweden.

It is planned to use a mixture of technologies comprising both fibre access and VDSL2 technology. Depending on the specific local/regional circumstances, TeliaSonera will rely on point-to-point fibre, PON, and VDSL2 from existing local exchanges.

¹⁸² This mainly refers to FTTB and use of CAT5 cable in-house.

¹⁸³ TeliaSonera has been involved in some collaborative, local municipal projects and has hooked up some buildings with fibre LAN extensions to individual apartments, in a few major cities in Sweden. In Finland TeliaSonera has already announced to start FTTH deployment. See LightReading Europe, March 13, 2008; http://www.lightreading.com/document.asp?doc_id=148297&print=true; downloaded June 3, 2008.

TeliaSonera underlined that there are no plans to deploy remote DSLAMs in street cabinets as part of a FTTC/VDSL strategy, rather, if fibre is deployed then it will rely on FTTB. TeliaSonera has announced that the broadband upgrade will also necessitate additional capacity in the metro networks and in the core network.

Deploying the new infrastructure, TeliaSonera will collaborate with external parties such as municipalities, building owners and housing co-operatives, see below. TeliaSonera has committed to deploy the new high-speed access network not only in the major metropolitan centres but also in smaller towns and communities.

Municipal networks

The Swedish government initiated “neutral active networks” in 1999. These networks are mainly financed from tax revenues. TeleGeography reports that 119 out of 153 local fibre/LAN broadband networks in Sweden are directly owned by municipal authorities or municipally run companies.¹⁸⁴

The biggest of such local companies is Stokab. Stokab was founded in 1994 and is owned by Stadshus AB, which, in turn, is owned by the City of Stockholm. Stokab’s main task is the deployment, operation and maintenance of the fibre optic network in Stockholm and its surroundings as well as renting fibre connections. The business model is infrastructure focused, i.e. Stokab is the owner of an operator-neutral network which provides point to point dark fibre links to third parties (network operators as well as directly to end-users (businesses) based on commercial agreements. Stokab also administers and develops the overall communications network of the City of Stockholm, thus, supporting government and public institutions. The City of Stockholm has selected Stokab to be the only player allowed to deploy fibre within Stockholm. Apart from Stokab only Telia has rights of way anywhere in Sweden, i.e. also in Stockholm. Thus, competitors claim to have a disadvantage.

Stokab deploys “Fibre to the Neighbourhood” but also FTTB (basement of the building). Stokab pursues a specific technical deployment approach. Within a defined area a specific building is selected which is to become a so called “block node”. Each block comprises about 250 apartments. Fibre is then deployed first between the metro network and the basement of the designated block node. Then Stokab installs a multiduct system through all basements of the buildings within the block in a ring structure. Each building is equipped with a delivery point at which Stokab can clamp in a bidirectional way a micro duct from the multiduct ring. In case a house owner wants to get access to a specific broadband operator the fibre strand will be blown into the duct.

¹⁸⁴ Alternative telcos marketing direct fibre services include Telenor and its two local subsidiaries Bredbandsbolaget (a.k.a. B2) and Glocalnet, Tele2, and TDC Song.

Deploying its network infrastructure Stokab can make use of infrastructure of other utilities (water, electricity). Stokab uses also railway and metro infrastructure as well as under water cable.

Regarding in-house infrastructure Stokab is cooperating with real estate companies like e.g. Svenska Bostäder, Familjebostäder, or Stockholmshem which implement the passive in-house cabling. Also the real estate companies are using micro ducts through which the fibre required by their tenants are blown.

Stokab reports¹⁸⁵ that its current network comprises 1 million fibre km, 4.500 cable km, 300 cross connects and 6,000 ODFs. In April 2008, the City of Stockholm has decided to give Stokab the task to roll out fibre to an additional 300,000 households in Stockholm. This project is planned to be finalised in 2012; Stokab will then reach 90 % of all households in Stockholm.

5.6.1.2 Regulation, wholesale services

Access to dark fibre, ducts

TeliaSonera has been obliged by regulation to provide dark fibre as backhaul to MDF's. However, this decision by PTS has been overruled by the Administrative Court. Thus, TeliaSonera today does not have an obligation to provide dark fibre to wholesale customers.

Telia has sold/rented dark fibre to competitors, often used for backhaul purposes. However, market players from Sweden report that TeliaSonera has ceased providing this, resulting in a substantial downturn of the ULL business.

Moreover, there is an access option which is called "WDM" offered by Telia, i.e. it is based on wave division multiplexing. However, to the best of our knowledge Tele 2 usually is the only applicant, in reality it is dark fibre that is delivered.

There is no regulation in place in Sweden regarding access to ducts. Also duct sharing is not offered in Sweden at the moment.

Municipal networks

Several market participants stress challenges for competition policy and regulation with respect to the municipal networks mentioned above.

One issue addressed is that public money has been given to the municipalities to deploy broadband infrastructure only in areas where it is uneconomic for market players to do so. The actual behaviour of municipal network entities, however, is not meeting this requirement, rather, so market players claim, they are deploying infrastructure also

¹⁸⁵ See Lundberg (2008).

in areas where it would very well be reasonable for a competitor to deploy own infrastructure. Thus, such a situation is viewed as not being market conform. ¹⁸⁶

The fact that the municipal fibre networks have been funded by government gives rise to another claim: interviewees argue that the networks should be open for wholesale customers. However, several municipalities have chosen not to provide dark fibre or no access to their infrastructure at all. Rather, they are migrating to offer capacity products (e.g. managed bandwidth). Some of them have even started offering competing services in the retail market, thus, becoming Full Service Providers.

Several market participants from Sweden claim that the prices of municipal fibre network providers are not market driven. In addition, they point out that virtually no SLAs are available.

Helgesson (2007), representing the B2 view, claims that the “neutral active networks” (i.e. the networks deployed and owned by municipalities) have effectively put a brake on fibre growth in Sweden, i.e. that FTTB/H is losing market share to LLU solutions. The author therefore stresses that actions are needed on neutral active networks; in particular they should neither be allowed to receive government funding nor be seen by officials as the only “acceptable solution”.

Access to sub-loops, bitstream access

TeliaSonera is obliged to provide access to sub-loops under its obligation in the ULL-market. However, this option has only been used by alternative network operators to a very limited extent to date. The main issue in this context is the roll-out costs. Market participants mention a number of arguments: information about the street cabinets is limited; TeliaSonera does not offer collocation in street cabinets; TeliaSonera does not provide back-haul to cabinets, and TeliaSonera limits the use of VDSL from cabinets to cabinets placed more than 1,400 metres from MDFs.

Bitstream is provided by TeliaSonera from MDFs and aggregated in 100 interconnects around the country.

Access to information

Regarding ducts and dark fibre there is no aggregated information available. Rather, market participants from Sweden point out that requests on availability are made on a case by case basis. They claim that the NRA is informed but has so far not been able to enforce regulation to solve the problem.

¹⁸⁶ Helgesson (2007) concludes that the municipal network approach, actually designed for rural areas, skews competition in larger, densely populated cities.

Aerial deployment

Our interviewees report that aerial deployment is allowed in Sweden.

Phasing out of MDFs, stranded investment

Competitors confirm that so far the investments made by TeliaSonera have not led to their investments being stranded. They stress, however, also that the reference offer for ULL in Sweden provides TeliaSonera with the possibility to phase out MDF's without any compensation for a competitor.

5.6.2 Model results

5.6.2.1 Country specific assumption

The total potential broadband customer base in Sweden amounts to 5.3 mill. customers. This number includes customers which are currently using cable modem services, mobile-only households and non-users of electronic communication services. For this reason the de facto addressable market for fixed-line operators may be smaller.

Cable is a very relevant broadband technology in Sweden. Cable operators currently have a 19% market share in broadband. The number of mobile-only households in Sweden amounts to only 3% which is well below the European average of 24%¹⁸⁷. Thus, taking these numbers as a reference for the future, it may become difficult for fixed-line operators to address more than 80% of the potential customer base.

In Sweden nearly no inhabitants live in high density areas as defined by our density criteria. Only 0.4 mill. customers are located in the less urban cluster. The majority of customers live in suburban and less suburban areas (39.2 %) and in dense rural and rural areas (42.5%).

¹⁸⁷ See EU Commission (2008).

Table 44: Spatial distribution of the customer base in Sweden

Sweden			
Cluster Type	Customer Base		
	in mill.	in %	accumulated %
Dense Urban	not existing	not existing	not existing
Urban	not existing	not existing	not existing
Less Urban	0.4	8.0	8.0
Dense Suburban	0.5	10.3	18.3
Suburban	0.7	13.7	32.0
Less Suburban	1.4	25.5	57.5
Dense Rural	0.5	8.7	66.2
Rural	1.8	33.8	100.0
Total	5.3	100.0	

Source: WIK-C

Table 45 outlines that this distribution of the population is reflected in the relatively high number of MDFs (8,200). On the other hand, there are only about 4 street cabinets per MDF reducing the investment needs for rolling out VDSL.

Table 45: Structural parameters of the PSTN network in Sweden

Structural parameter	Value
Total number of main distribution frames	~ 8,200
Total number of street cabinets	~ 30,500
Average sub-loop length (in metres)	~ 330

Source: WIK-C

In Table 46 our revenue assumptions for Sweden are shown. The relatively low level of the average revenue (34.2 € per month) reflects the high degree of competition in the Swedish broadband market.

Table 46: Assumptions on average revenues per subscriber in Sweden

Type of subscriber	Average revenue per subscriber (in €)	Share of the total customer base (in %)
Single Play	16.5	18.0
Double Play	34.5	58.6
Triple Play	45.0	13.5
Business	50.0	9.9
Total	34.2	100.0

Source: WIK-C

For all scenarios we assume a WACC of 9.2% which reflects the interest rate the Regulatory Authority uses to calculate regulated wholesale prices of TeliaSonera.

5.6.2.2 Model scenario results

As already suggested by the distribution of population and the structure of the network, VDSL can profitably be rolled out only for 18.3% of the customer base. However, the roll-out conditions are attractive in these areas. The incumbent would only need a 2% market share for profitability in the less urban cluster and 12% in the dense suburban cluster.

Table 47: Critical market shares under different market and regulatory scenarios for rolling-out VDSL in Sweden¹⁸⁸

VDSL - S									
Cases	Accumulated Customer Base		First Mover Cases		Second Mover Cases				
	Cluster	Stand Alone	Incumbent	80% Infrastructure Sharing	80% Dark Fibre and Infrastructure Sharing	80% Dark Fibre and Infrastructure Sharing	20% Infrastructure Sharing	20% Dark Fibre and Infrastructure Sharing	20% Dark Fibre
Dense Urban	not existing	not existing	not existing	not existing	not existing	not existing	not existing	not existing	not existing
Urban	not existing	not existing	not existing	not existing	not existing	not existing	not existing	not existing	not existing
Less Urban	8.0%	19%	2%	25%	20%	20%	32%	31%	31%
Dense Suburban	18.3%	n.v.	12%	n.v.	98%	71%	n.v.	n.v.	n.v.
Suburban	32.0%	n.v.	n.v.	n.v.	n.v.	n.v.	n.v.	n.v.	n.v.
Less Suburban	57.5%	n.v.	n.v.	n.v.	n.v.	n.v.	n.v.	n.v.	n.v.
Dense Rural	66.3%	n.v.	n.v.	n.v.	n.v.	n.v.	n.v.	n.v.	n.v.
Rural	100.0%	n.v.	n.v.	n.v.	n.v.	n.v.	n.v.	n.v.	n.v.

n.v. = Not viable
Source: WIK-C

¹⁸⁸ The percentage values in the table indicate the critical market shares for profitability, i.e. the revenue – cost break even.

Second movers need, in all scenarios, much higher market shares for profitability and they can profitably invest in VDSL only in the less urban cluster, even with a supportive regulatory framework. The critical market shares indicate potential replicability for more than one alternative operator under favourable regulatory conditions.

Similar to VDSL, the coverage of FTTH in Sweden can be extended to 18.3% or about 1 mill. of the broadband customer base. Parallel infrastructures are only viable in the less urban cluster or for 8% of the customer base. If alternative operators do not only obtain access to ducts but also to fibre SLU, replicability of FTTH-PON and therefore competition can be extended from the less urban to the suburban cluster. Also in Sweden, fibre SLU enables competition in the clusters where FTTH-PON is viable for a first mover.

Table 48: Critical market shares under different market and regulatory scenarios for rolling-out FTTH-PON in Sweden¹⁸⁹

PON - S									
Cases	First Mover Cases			Second Mover Cases					
	Stand Alone	Incumbent	Accumulated Customer Base	80% Infrastructure Sharing	20% Infrastructure Sharing	SLU + 80% Dark Fibre and Infrastructure Sharing	SLU + 80% Dark Fibre and Infrastructure Sharing	SLU + 20% Dark Fibre and Infrastructure Sharing	SLU + 20% Dark Fibre
Dense Urban	not existing	not existing	not existing	not existing	not existing	not existing	not existing	not existing	not existing
Urban	not existing	not existing	not existing	not existing	not existing	not existing	not existing	not existing	not existing
Less Urban	26%	16%	8.0%	28%	30%	5%	5%	11%	11%
Dense Suburban	87%	49%	18.3%	80%	98%	30%	37%	72%	70%
Suburban	n.v.	n.v.	32.0%	n.v.	n.v.	80%	80%	n.v.	n.v.
Less Suburban	n.v.	n.v.	57.5%	n.v.	n.v.	65%	86%	n.v.	n.v.
Dense Rural	n.v.	n.v.	66.3%	n.v.	n.v.	n.v.	n.v.	n.v.	n.v.
Rural	n.v.	n.v.	100.0%	n.v.	n.v.	n.v.	n.v.	n.v.	n.v.

n.v. = Not viable
Source: WIK-C

¹⁸⁹ The percentage values in the table indicate the critical market shares for profitability, i.e. the revenue – cost break even.

As Table 49 shows, only the incumbent operator could profitably build a FTTH-P2P network in the dense suburban cluster and for 18.3% of the customer base. Alternative operators can theoretically roll out a P2P network in the less urban cluster. The high market shares required, however, indicate that de facto a P2P network will not be replicable in Sweden at all. The only way to introduce competition at the network level requires the availability of fibre LLU.

Table 49: Critical market shares under different market and regulatory scenarios for rolling out FTTH-P2P in Sweden¹⁹⁰

P2P - S					
Cases		First Mover Cases		Second Mover Cases	
Cluster	Accumulated Customer Base	Stand Alone	Incumbent	80% Infrastructure Sharing	20% Infrastructure Sharing
Dense Urban	not existing	not existing	not existing	not existing	not existing
Urban	not existing	not existing	not existing	not existing	not existing
Less Urban	8.0%	28%	19%	49%	38%
Dense Suburban	18.3%	n.v	62%	n.v	n.v
Suburban	32.0%	n.v	n.v	n.v	n.v
Less Suburban	57.5%	n.v	n.v	n.v	n.v
Dense Rural	66.3%	n.v	n.v	n.v	n.v
Rural	100.0%	n.v	n.v	n.v	n.v

n.v. = Not viable

Source: WIK-C

¹⁹⁰ The percentage values in the table indicate the critical market shares for profitability, i.e. the revenue – cost break even.

5.6.2.3 Summary of results

Figure 53 and Figure 54 below summarise the NGA roll-out opportunities in Sweden for the incumbent and for alternative operators under favourable regulatory conditions.

Figure 53: NGA roll-out opportunities of the incumbent by technology in Sweden

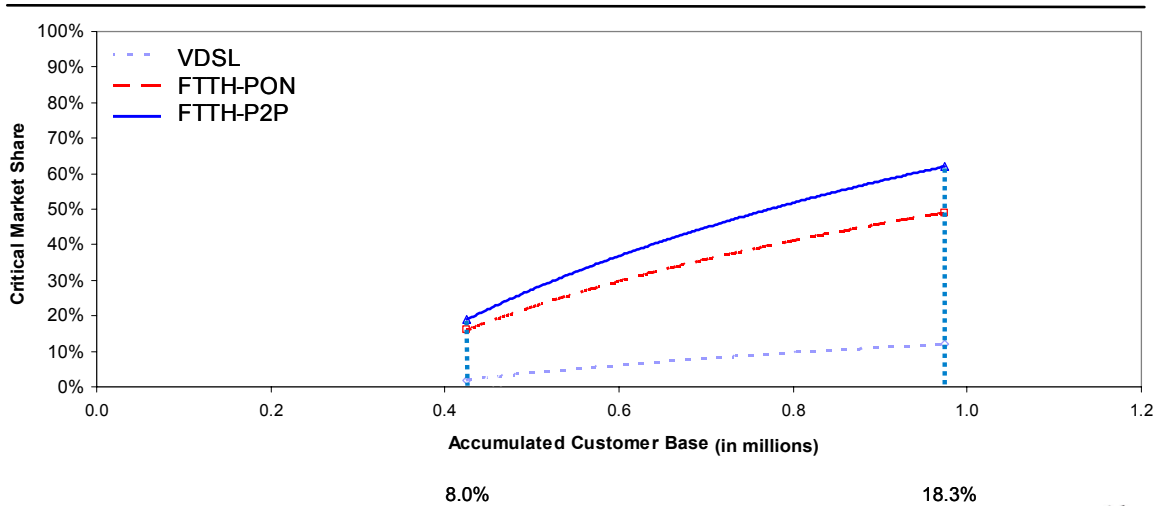

Source: WIK-C

Figure 54: NGA roll-out opportunities of an alternative operator in case of 80% infrastructure sharing in Sweden

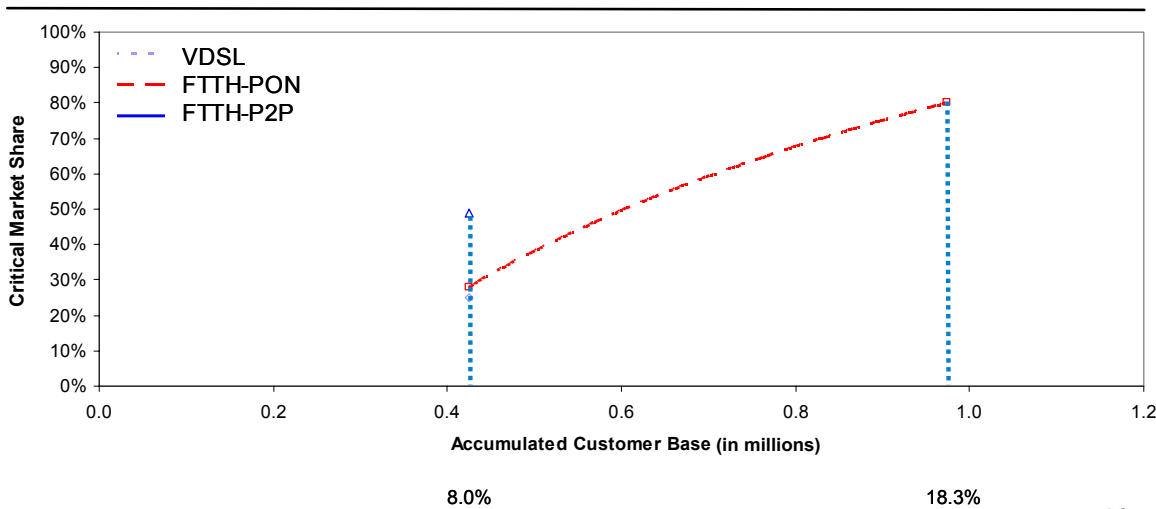

Source: WIK-C

We summarise the results as follows:

- (1) Any NGA technology can be rolled out in Sweden for only 18.3% of the customer base.
- (2) FTTH needs significant higher critical market shares than VDSL.
- (3) The roll-out conditions of VDSL are very attractive in two clusters.
- (4) Infrastructure-based replicability, if at all, is limited to just one cluster in Sweden.
- (5) De facto alternative operators can only compete as second movers in FTTH, if fibre SLU in case of PON and fibre LLU in case of P2P is available as an access opportunity.
- (6) Already for a longer period of time there is public funding for FTTH infrastructures in the urban and suburban areas. Thus the only attractive areas for private NGA investment already have been covered.
- (7) Since VDSL is less future proof than FTTH (supports less bandwidth) one could expect that nobody would invest in VDSL competing with already existing FTTH public accessible infrastructure.
- (8) In order to cover the more rural areas one could expect that the public funding of FTTH infrastructures will be continued, maybe supported by wireless access solutions in the extremely sparse populated areas.

5.7 General results

- (1) We modelled three architectural approaches for NGA, FTTC-VDSL, FTTH-PON and FTTH-P2P. In general, their profitability (in terms of coverage and critical market share to be achieved) is ranked in the order above, the most profitable is VDSL, followed by PON and then by P2P. This ranking does not consider whether the different capabilities support high bandwidth, are future proof and ease an unbundling approach. Likewise, it does not consider the possible degree of replicability in the case of fibre SLU/ LLU. ¹⁹¹

¹⁹¹ VDSL might not be a suitable solution for broadband access networks due to technical or operational restrictions. On the one hand, a major amount of copper sub-loops (e.g. 25%) is longer than 1 km (like in France with an average sub-loop length of 750m) the bandwidth on these lines is reduced to ADSL or even less, unsuitable for high speed broadband transmission. On the other hand, the street cabinets do not allow to disseminate the heat of the active equipment (the DSLAMs) or only at prohibitive costs.

- (2) The costs of access network infrastructure depend on the population density of the area served. Therefore we define clusters of the same line density per country and calculate the profitability for each cluster independently. The results confirmed our basic assumption: the denser populated the more profitable the NGA business in that area.
- (3) All cases show that the roll-out for a NGA network is not profitable for all regions (clusters) of a country, neither for the incumbent nor for its competitors¹⁹².
- (4) Profitability/viability in our model is measured by the size of the critical market share in a dedicated cluster needed for a revenue/cost break even. The lower the critical market share the higher the profitability (and below certain values the replicability). In order to compare architectural approaches and/or regulatory measures for a country one does not only have to compare the critical market shares per cluster but also the profitable degree of population coverage.
- (5) The market share we use is the share of the total customer base, including TV-cable network and mobile-only users and the amount of users not using telecommunication networks at all. Thus, the market for broadband services will effectively be smaller and the critical market shares in terms of the de facto addressable market will therefore be larger than the figures in this study.
- (6) We modelled two first mover cases, one for the incumbent and one for an operator not having the incumbent history and advantages. The model results show an advantage for the incumbent in all three architectures due to the fact that it better takes advantage of sharing the infrastructure with additional non NGA usages (e.g. leased lines) and of closing/selling of MDF sites.
- (7) The figures shown for the incumbent cases rely on two basic assumptions underestimating the profitability for the incumbent in comparison with the other operators, the static approach (no ramp up cost considered, better time to market for the incumbent) and the LRIC bottom-up type of modelling (cost considered for already existing and depreciated infrastructure) (see sections 4.2.1 and 4.2.2).
- (8) We have modelled several regulatory measures relating to the use and share of infrastructure (section 4.1.4). These measures can be combined with each other in rational variants. Some combinations of regulatory measures result in more efficient network roll-outs than pure solutions of one type, depending on the architecture (e.g. in a P2P architecture the self construction of ducts in the backhaul segment may be more profitable than renting existing ducts or even dark

¹⁹² There is one exception for VDSL in Italy, which is at the edge of viability in the rural cluster (section 5.3.2.2, Table 25).

fibre¹⁹³). Thus, the choice between different regulatory options (wholesale products) increases profitability and hence replicability for second movers.

- (9) Replicability, if at all, is only given in the denser populated areas.
- (10) The options of duct access or fibre access improve the profitability/ replicability of second movers, but still to a limited amount of population in the order of decreasing population density and the order of architectural solutions already described in (1) (VDSL, PON, P2P). They will not significantly improve replicability.
- (11) Fibre LLU in case of P2P and fibre SLU in case of PON increase replicability significantly and enable viable competition in all clusters where a first mover rolls out the FTTH infrastructure. Replicability is not given in the less populated clusters (e.g. less suburban and below, depending on national circumstances).
- (12) Additional revenues from an infrastructure wholesale business improve the business case for the incumbent even more (section 5.4.2.4), lowering the critical market shares and perhaps enlarging the customer base, thus reducing the risk of investment. Any wholesale offering improves the NGA profitability conditions of the incumbent. Offering duct access, however, is more profitable than offering fibre SLU/ LLU.
- (13) Increasing the WACC for the calculation of wholesale infrastructure products in order to consider the additional risk of an incumbent to invest in the NGA business (or for other reasons) results in deteriorating profitability and replicability for the competitors (section 5.2.2.4) significantly and in improving the profitability for the incumbent.
- (14) Increasing or decreasing the ARPU by the same percentage results in disproportionate effects on the critical market share. The relative effect of decreasing the ARPU is stronger than the relative effect of increasing it. In general, the 'elasticity' is greater than one: the relative change of the critical market share is higher than the relative change of the ARPU (section 5.1.2.4).
- (15) A decrease of infrastructure costs improves profitability and coverage significantly. Several possibilities can be observed: non-discriminatory use of existing public infrastructure at low cost (e.g. sewers in Paris), non-discriminatory use of existing infrastructure of the incumbent (e.g. Socrate infrastructure in Italy), low construction costs (e.g. Portugal), high degree and sharing of aerial infrastructure (e.g. Portugal, Italy,...), the use of fibre SLU and LLU, and last but not least, effective and cooperative processes to get access to existing infrastructure (not

193 See sections 5.4.2.2 (Table 34) and 5.5.2.2 (Table 43) for examples.

considered in the cost model). These factors have been used to parameterize the model for each country.

- (16) The investment per home passed in the case of a stand-alone operator (not being the incumbent, without regulatory measures) connecting all homes in the viable clusters differs from country to country and is increasing from cluster to cluster. Table 50 presents the investment per home passed in the urban cluster across all countries as an example¹⁹⁴. The figures do not include investment for CPE or inhouse cabling since this investment will be conducted only if the customer is connected to the network.

Table 50: Investment per home passed (in Euro), urban cluster, stand-alone first mover*

Network Type	Country [in €]					
	DE	FR	SE	PT	ES	IT
VDSL	201	n.v.	149	82	100	190
PON	793	619	393	616	714	389
P2P	919	930	530	776	859	504

* Based on the investment of the urban cluster. No consideration of inhouse cabling and CPE.

Source: WIK-C

The difference between the VDSL and the FTTH stand-alone architectures is mainly caused by the fact that the distribution cable segment in VDSL does not have to be invested; rather, it is rented via copper SLU. Portugal in general is cheaper in its construction costs, which is reflected in the investment requirements. Sweden has the shortest distribution cable length in the urban and less urban cluster, respectively. The effect of an attractively priced existing infrastructure can be observed in Italy (Socrate) and France. However, in France this effect is compensated by the long access lines.

The VDSL investment is the highest in Germany, followed by Italy, Sweden, Spain and Portugal. A comparison between Germany and Portugal points out that the investment in civil engineering is remarkably higher in Germany than in Portugal. In Portugal the digging cost per trench metre is relatively low and the same holds for the number of street cabinets which, in turn, determines the required number of trenches linking each street cabinet to the metro core location. Both parameters tend to decrease the investment in civil engineering. Another aspect for the

194 We have chosen the stand-alone case as a basis for comparison because it is defined by the lowest share of rented infrastructure and therefore it eliminates additional sources of differences between the countries. For the same reason we just have chosen a cluster of similar population density instead of calculating averages across all viable clusters, because these values are, besides others, influenced by the different ARPUs. For Sweden we have taken the less urban instead of the urban cluster, reflecting that population density starts with less urban.

difference between the two countries is the average number of subscribers per street cabinet which is higher in Portugal. In combination with a slightly lower investment per street cabinet it leads to half the per-subscriber investment in Germany.

If the roll-out focuses on FTTH-PON, an Italian operator can expect the lowest investment per home passed. On the contrary, the investment will be highest for a German operator. It is about two times higher than in Italy. The difference mainly results from the Socrate network. The Italian operator rents these existing ducts for about half of its required infrastructure and since the rent is considered as Opex it does not contribute to the investment value. De facto the investment figures in Italy are not comparable to those of the other countries. The same holds true of France where the investment level is in-between the two countries. Similar to Italy, the French operators use existing infrastructure (sewer systems) to some extent. However, the systems only partly exist in the urban cluster which we consider for the investment analysis, so beside renting ducts the operator has also to take into account own civil engineering work. However, the use of sewers leads to an investment which is lower than in Germany, but which is at about the level expected in Portugal.

An operator deploying FTTH-P2P faces highest investment in France. The investment in Germany is slightly lower due to the lower length of the distribution cables which is about two thirds of the level in France. Italy is the best place to deploy P2P at least if investment is considered only.

- (17) The investment per home connected depends on the cluster considered and on the market share being achieved (in Table 51 we assume the urban cluster and a market share of 50%) ¹⁹⁵. The figures include inhouse cabling and CPE in any of the countries. While the cost of the passive infrastructure differ due to varying construction cost, existing infrastructure (ducts/ aerial cabling) and network topology the cost of the active equipment more or less is the same in all countries.

¹⁹⁵ We compare one cluster with a dedicated market share. Taking the individual critical market shares per cluster would result in different values per architecture, cluster and country and would hardly be comparable.

Table 51: Investment per home connected**, market share 50%, urban cluster, stand-alone first mover¹⁹⁶

Network Type	Country [in €]					
	DE	FR	SE	PT	ES	IT
VDSL	457	n.v.	352	218	254	433
PON	2,039	1,580	1,238	1,411	1,771	1,110
P2P	2,111 (54%)	2,025	1,333	1,548	1,882	1,160

** Based on the investment of the urban cluster and a market share of 50%. If other market shares are used, it is mentioned in brackets.

n.v. – not viable

Source: WIK-C

The relatively high value for PON in Germany is inter alia caused by the relatively low number of customers per splitter site (street cabinet).

The investment for homes connected is higher than the one for homes passed, but in both cases the trend across the countries is quite similar. The similar trend is reasonable since the structural factors which determine the trend of homes passed investment, such as trench length, investment per trench metre and number of street cabinets, are the same as for the homes connected case. The higher level of the investment for homes connected relative to homes passed results from the equipment (CPE, trunk cards, inhouse cabling for PON and P2P) additionally considered. Moreover, the investment for the complete network deployment is borne by only 50% of the potential customer base while the analysis on homes passed refers to 100%.

The additional costs differ across country and network architecture. For VDSL they are lower than for PON and P2P. The lower additional costs for VDSL mainly result from the use of already existing inhouse cabling on the customer premises. However, the two FTTH techniques require optical fibres within the premises, so investment for inhouse cabling becomes eminent. Across countries the different values mainly result from the investment for inhouse cabling which rises from the southern to the northern countries.

- (18) The structure of the investment between active and passive components based on a market share of 50% of homes connected (see (17)) is shown in Table 52 for the example of Germany.

¹⁹⁶ In Germany the critical market share for a P2P architecture in the urban cluster is 54%.

Table 52: Shares in investment for active and passive equipment, market share 50%, urban cluster, stand-alone first mover, Germany

	VDSL	PON	P2P
Share of active equipment in total investment, homes connected (in %)*	~ 44 %	~ 8 %	~ 11 %
Share of passive equipment in total investment, homes connected (in %)*	~ 56 %	~ 92 %	~ 89 %

* Urban cluster, considers inhouse cabling and CPE, market share 50 %

Source: WIK-C

The VDSL architecture relies on copper SLU and therefore requires less construction investment, thus less passive but more active investment for each street cabinet. The P2P architecture requires more active equipment because each customer connected has its separate port at the MCL, while with PON up to 64 customers are concentrated on a single fibre and a central port by passive splitters. The difference of cable construction cost can be seen in the models, but are compensated partly by the difference of the active equipment.

- (19) Our model results show the different distribution between Capex (Capital Expenditure) and Opex (Operational Expenditure) between the FTTC and FTTH architectures, already due to less Capex in the case of VDSL. The values in the case of a stand-alone non incumbent operator in the urban cluster with 50% market share are given in Table 53. While with FTTC/ VDSL the Capex/ Opex ratio is around 35%/ 65% the respective ratio for FTTH is around 68%/ 32%. Between the two FTTH architectures there is no significant difference. The differences between the countries are caused by the already mentioned differences in the Capex for the passive infrastructure.

Table 53: Capex/ Opex ratio (in %) across technologies and countries (market share 50 %, urban cluster, stand-alone first mover)

Country		Network Type		
		VDSL	PON	P2P
DE	Capex	39	72	71*
	Opex	61	28	29*
FR	Capex	n.r.	69	70
	Opex	n.r.	31	30
SE	Capex	37	66	66
	Opex	63	34	34
PT	Capex	25	66	67
	Opex	75	34	33
ES	Capex	33	70	70
	Opex	67	30	30
IT	Capex	46	61	61
	Opex	54	39	39

* The critical market share is at 54 %

n.r. - not replicable

Source: WIK-C

6 Conclusions and recommendations

6.1 Findings and conclusions

6.1.1 The economics of NGA

- (1) Investment in NGA is an inevitable next step for communication networks to meet the future-proof requirements of capacity, speed and quality of electronic communications in the future. But the timing and urgency for NGA investments vary by country and depend partly on sufficiency of existing xDSL solutions.
- (2) Despite the high investment requirements, fixed-line operators are under pressure to develop a NGA strategy. Failure to deliver services beyond ADSL2+ may otherwise result in the loss of customers due to a renascent cable TV industry.
- (3) NGA developments will also give rise to innovation opportunities at both the service/application and the infrastructure level.
- (4) NGA development will have a significant impact on future market structures of electronic communications networks; this impact will be stronger than the impact of the NGN in general.
- (5) The economics of NGA will determine a new equilibrium between infrastructure-based and service competition.
- (6) NGA roll-out can rely on a more efficient network architecture than the current PSTN access network.
- (7) Besides network technology/architecture factors and the cost of network elements, the profitability of NGA roll-out and NGA replicability also critically depends on the ability of operators to generate higher ARPU and/or margins for services offered on NGA infrastructure. However, sustainability of higher prices is doubtful given upward substitution from existing xDSL services and competition from cable TV. Experience from early broadband deployment also suggests that at high prices, demand for high speed services would be significantly restricted.
- (8) Access to buildings and sharing of in-house wiring is important to ensure effective competition.
- (9) We share the doubts that there will be more than one rolling out of in-house wiring because of costs, lack of space in cable trays and refusal of property representatives to grant access to more than one operator. The first operator deploying fibre in a building will obtain a de facto monopoly.

- (10) Aerial deployment of cable is characterised by lower Capex but higher Opex. Depending on local conditions (e.g. storms, snow, trees) Capex savings can be overturned by increased Opex. Nevertheless, under certain conditions and in certain countries aerial deployment of cable can reduce infrastructure costs and may be a factor to extend the roll-out of NGA geographically.
- (11) Incumbents are better placed than alternative operators to invest in NGA on a large scale:
- a. Incumbents can rely on the availability of major network elements needed for NGA (locations of street cabinets, ducts, fibre) where alternative operators still have to invest.
 - b. Incumbents can save (economically) investment by generating lump-sum revenues due to dismantling of MDFs.
 - c. Incumbents can make better use of economies of scale and scope due to their larger subscriber base (80-90% of local loop, around 50% of retail broadband customers) compared to 10-15% of the leading competitor, which they can switch to NGA.
 - d. Alternative operators usually face higher cost of capital than incumbents due to their size and risk position.
 - e. Due to the factors mentioned above, investments in NGA are more risky for alternative operators than for incumbents. Yet, alternative operators may act as first movers in NGA, because their current business model as a whole is under threat.
- (12) In case of FTTH the NGA architecture of P2P is more consistent with the principle of open networks than a PON architecture.

6.1.2 Findings from international comparison

- (1) With more than 11 mill. FTTB/H subscribers, Japan is leading NGA fibre deployment in the world. The Japanese market reveals important insights for the European development:
- a. Once FTTB/H is available in the market, it has the potential to (easily) substitute for and overtake DSL.
 - b. If the deployment of fibre is organised very cost-efficient, e.g. via aerial deployment, greater replication of fibre access seems to be possible than in

- a duct/buried cable environment. Replication is also supported by ultra-high densities in Japanese cities.
- c. Access-based competition on the basis of unbundling of fibre loops does not foreclose competing fibre access infrastructure.
 - d. Despite infrastructure-based and access-based competition, the incumbent can keep a SMP position for FTTB/H.
 - e. So far FTTB/H has not increased ARPU significantly above the level of ADSL.
- (2) Although policy decisions regarding NGA are not completely taken, it is remarkable that the Australian Government has announced to invest in a nationwide FTTN network on the principle of open access to all service providers. This decision followed unsuccessful attempts to bring together the incumbent and alternative operators to jointly invest in a FTTN infrastructure.
- (3) Singapore is going to set up a more governmentally controlled approach towards NGA:
- a. By means of a licensing approach (based on competitive bidding) passive infrastructure provision is structurally separated from active infrastructure provision. Active infrastructure provision is operationally separated from retail service provision.
 - b. Both wholesale companies will act as regulated monopolies, have to provide services on a non-discriminatory basis, face universal service obligations and will receive some public subsidies.
- (4) The US broadband market is mainly characterised by a duopoly between cable companies and the two fixed-line incumbents (in geographically separate areas). Since the abolition of unbundling obligations regarding fibre in 2003, competitive access providers only play a negligible role in the broadband market.

6.1.3 Policy and regulatory conclusions

- (1) NGA developments are relevant to Markets 1, 4, 5 and perhaps 6 of the second edition of the European Commission Recommendation on relevant product and services markets susceptible to ex-ante regulation.
- (2) NGA development per se does not require to address the issue of sub-national markets. NGA will only have an impact on the need to define sub-national markets for certain markets and/or to differentiate remedies on a geographic basis if the

degree of replicability of access services will be increasing due to NGA investments.

- (3) Transparency about planned deployment of NGA networks is a prerequisite both for developing a proper regulatory framework for effective transition and for providing economic efficient incentives for NGA deployment. This presumption holds in particular for the investment decisions of alternative operators; it is, however, of important relevance for incumbents' investment decisions as well.
- (4) Despite the fact that NRAs have the legal power based on Art. 5 FD to request the relevant information from operators, there is significant lack of transparency of the incumbents' NGA strategy and the future of the existing unbundling wholesale services in many Member States. Lack of transparency can increase the level of sunk cost in the transition to NGA, can generate economically unjustified first mover advantages and reduce the potential for competition in NGA.
- (5) Enhancing the provision of rights of way for operators can reduce the civil engineering costs in deploying FTTB/H NGA strategies and increase the pace of deployment.
- (6) In order to facilitate competing fibre local loops, reduce costs and reduce multiple excavation and other civil works in municipalities, the sharing of existing ducts of telecommunications and cable companies, but also those of other utilities, is an important policy requirement.
- (7) Efficient access to ducts requires transparency in available spare capacity in the form of easily accessible directories, data banks or web portals. Case-by-case and duct-by-duct inquiries do not fit with this requirement. NRAs have to ensure proper reference offers including cost-based prices and efficient SLAs.
- (8) NGA will require a change in regulatory paradigms: The issue of access regulation in an NGA context no longer is solely how to provide access to existing network elements or services but also how to structure new network elements such that efficient access opportunities do emerge.
- (9) Unless European regulation takes proper and timely action, NGA deployment by incumbent operators can significantly reduce the (already limited) degree of competition in the access market currently reached on the basis of unbundling.
- (10) Investment in NGA can generate significant and sustainable first-mover advantages. First-mover advantages can limit the ability of second-movers to reach the necessary market shares for replicability and profitability. Even where our modelling results suggest replicability, in a real market environment this result may be jeopardised by first-mover advantages. Avoiding incumbents' first-mover advantages becomes a relevant goal of regulation under such circumstances.

- (11) Regulatory intervention and proper access products are needed for a competitive NGA market:
- (a) Duct and dark fibre access increase the level of infrastructure replicability, but are not sufficient for viable competition.
 - (b) Physical collocation at the street cabinet level increases the limited degree of replicability in case of FTTC.
 - (c) Fibre full local loop unbundling (at metro core locations) and fibre sub-loop unbundling (at OSDF) increase the scope for competition significantly.
 - (d) Bitstream access remains relevant to support the ladder of investment concept, for areas of non-replicability of infrastructure and for business service providers.
 - (e) In addition, the regulatory framework has to deal with the sunk investments of competitors related to LLU infrastructure to enable a viable migration path to NGA.
- (12) The limited degree of replicability of competing NGA infrastructure-based approaches underlines the growing importance of the adequate provision of bitstream access to support at least competition in the provision of NGA services.
- (13) The availability of high-quality bitstream is also crucial for business service providers, who are not targeting the mass market. They are often addressing rather widely dispersed customers on a nationwide or even pan-European basis. As they are addressing a significantly smaller customer base, this is not sufficient to reach the scale of operations economically justifying self provision of access services in many cases.
- (14) The availability of bitstream access in a NGA environment furthermore supports the ladder of investment concept given the incumbents' first mover advantages. Bitstream access also generates competition e.g. in less urban or rural areas where the economics of NGA do not support replicability of NGA infrastructure at all.
- (15) Given the limited degree of replicability of NGA, bitstream will remain an important element of the regulatory strategy in an FTTB/H environment. Bitstream should be made available on a technologically neutral basis spanning the full capacity of the available infrastructure.
- (16) The (high) risk of NGA investment, different costs in regions, different degrees of replicability and the ladder of investment concept can only be coped with if alternative operators can choose between different access opportunities.

Depending on local roll-out conditions, in one city or for one network layer, access to ducts may be the more efficient product. In others it may be dark fibre. Formulating a hierarchy of access opportunities entails the risk of inefficient infrastructure investment. This conclusion is supported by our model results.

6.1.4 Conclusions based on our model results

- (1) The economics of NGA networks vary, according to our model results, across different technologies, network architectures and different geographic areas depending on customer density and the cost of infrastructure deployment.
- (2) Our model results show that NGA conditions differ among Member States and within different regions of Member States. This does not necessarily mean that markets have to be defined as sub-national markets.
- (3) A nationwide NGA roll-out is not profitable in any of the six countries analysed. This result holds for any NGA technology and even for a monopolistic market structure.
- (4) The area of NGA coverage beyond the level of profitable roll-out can only be expanded with public funding or subsidies.
- (5) Our model exhibits the importance of scale and scope economies limiting the degree of replicability. Where viable, replication of the incumbent NGA will require a more significant scale and market share for alternative operators as compared to current unbundling business models, limiting the number of feasible competitors in the access network.
- (6) Properly defined access remedies and/or wholesale products increase the degree of replicability of NGA access infrastructure and therefore the degree and potential for competition.
- (7) Replicating the incumbents' VDSL network roll-out by alternative operators is less viable than the current LLU approach of alternative operators. In a VDSL NGA environment, the current degree of LLU based competition does not seem to be replicable. These results are similar to those generated in studies for NRAs in the Netherlands, Ireland and Belgium.
- (8) Our model results have proven the critical importance of efficient collocation at the level of street cabinets to replicate FTTC NGA strategies. Total cost of collocation can (only) be minimised if new street cabinets are ex-ante designed for collocation capabilities.

- (9) Our model results have proven the critical and quantitative importance of efficient backhaul solutions between the street cabinet and the operator's network node. Stand-alone backhaul services limit the replicability of FTTC NGA development significantly. Thus, the availability of proper access products improves replicability.
- (10) Our model results support the expectation that collocation at the incumbents' street cabinet improves viability and replicability of VDSL by alternative operators compared to collocation nearby.
- (11) As indicated by other studies and/or analytical expectations, our model results support the finding that civil engineering cost and in-house wiring are key barriers to replicability in FTTB/H NGA deployment, but addressing these will not alone be sufficient to deliver competitive outcomes.
- (12) In an FTTH NGA environment, the degree of competition based on LLU as of today can only be replicated if fibre SLU (in case of PON architecture) and/or fibre LLU (in case of P2P architecture) are available as access products.
- (13) Our model results show that incumbents can reduce their own costs by infrastructure sharing, can increase the profitability of their NGA roll-out and can reach profitability at a lower level of market share. This result suggests that investment cases of incumbents may be improved rather than undermined through open access regimes.
- (14) The economics of FTTx do not support multiple replication of the access network. In case of (theoretical) replicability usually only one or two operators (in addition to the first mover) can profitably invest in NGA infrastructure. From our model results we can derive a limited degree of replicability for certain denser populated regions and/or cities but not on a nationwide basis.
- (15) Our model results underline the importance of efficiency in the duplication of infrastructure. If more access networks are rolled out than suggested viable by the model or if particular access network providers fail to achieve the critical market shares calculated, market players would either need to charge higher retail prices to recoup their investment or have to face major stranded investment failing to make a fair return on investment. A similar situation due to overinvestment has occurred when the internet bubble burst in 2000/01.
- (16) Our model results show symmetric opportunities for incumbents and alternative operators to reach the relevant market shares for a profitable NGA deployment. Under real market conditions there are, however, a variety of asymmetries between incumbents and alternative operators to invest in NGA. The major asymmetries result from the use of existing network infrastructure and the large customer base.

- (17) Sensitivities on the level of the cost of capital show the critical dependency of NGA profitability from this parameter. Increasing the WACC in France for instance from 10.25% to 15% reduces the viable coverage of a PON FTTH infrastructure from 18.6% to 6.8% of population. In the viable areas the critical market shares for profitability increase significantly. If only the WACC for the regulated wholesale services of the SMP operator is increased by the same degree, the critical market shares (or the costs) of competitors increase significantly and the viably addressable customer base decreases. These results show, how careful regulators have to deal with a risk premium approach to incentivise investments in NGA. If wholesale rates are fixed significantly above the relevant NGA project risk, replicability and competition can be heavily affected.

6.2 Recommendations

6.2.1 Recommendations addressed to European policy-makers

- (1) The economics of rolling out fibre access networks require high market shares which in most cases are not compatible with effective competition. This is a long term issue relating to the high costs of laying physical infrastructure in a typical European environment (medium density, buried cables). Policy-makers should set realistic objectives for regulators on this basis which recognise that there are structural barriers to infrastructure-based competition in the access network and more widely in rural areas which must be addressed by regulators to achieve effectively competitive outcomes.
- (2) Open access models should be positive for investors and favoured by policy makers exploiting the potential of innovation and competition.
- (3) Policy-makers should take care that local loop unbundling and sub-loop unbundling are defined in a technologically neutral manner that includes fibre lines and not just metallic lines. It is likely that regulated access to fibre networks will be needed, in addition to duct access, to deliver effective competition in most cases.
- (4) Policy makers should aim for efficient investment so that infrastructure is rolled out profitably, with minimum risk for the economy and with a maximum reach. Policy-makers should avoid making assumptions on the degree of investment which is efficient, but enable operators to invest efficiently based on a set of options (the ladder of investment).
- (5) Policy makers should promote service competition and infrastructure-based competition at the same time. Provided the wholesale price is right, regulated access to fibre does not preclude and can provide a platform for further infrastructure duplication where this is efficient.
- (6) Provided the wholesale bitstream access price is right, WBA remains a key element in the ladder of investment concept to develop markets and support market entry. Policy makers therefore should continue to consider WBA as one of the important elements to develop competition in broadband access markets
- (7) Incumbent operators retain a substantial advantage particularly through access to legacy infrastructure (ducts), often high retail market shares, ability to finance NGA investment from existing cash-flows, and information asymmetry. Even if duct access is addressed, first mover advantages are likely to be gained by dominant operators due to regulatory lag. Incumbents also have the capacity to reduce costs through selling other legacy property (particularly buildings) and may have fully or

partially depreciated some of the underlying duct infrastructure. These advantages should be taken into account when considering the relative positions of market players, their costs and capacity to invest.

- (8) Policy-makers and regulators must act quickly to identify their preferred model for NGA deployment and expectations regarding openness of networks. Whilst policy makers cannot mandate particular network structures, signaling expectations of reasonable access conditions in case of SMP and indicating that access pricing will be calculated on the basis of efficient architectures can help to ensure that access owners take account of requirements for openness in the network architectures they adopt.
- (9) Rewarding risk appropriately is important in ensuring that investment occurs. Suggested solutions have been to increase the allowed WACC for risky projects or to require up-front payments to benefit from access. Policy makers should, however, be aware, that certain models of risk rewarding and pricing are not compatible with competition or may at least harm competition. European or national legislation should adopt the principle that regulated prices allow a fair return appropriately reflecting risk, and that pricing structures adopted to achieve this should be compatible with promoting effective competition.
- (10) Because over-compensating investors through excessive access prices can negatively impact competition, policy-makers should not recommend particular (additional) risk premiums for all NGA investments. Investing in next generation access networks may be risky in some circumstances and may constitute relatively risk-free renewal of equipment in others. The assessment of the level of riskiness and calculation of the appropriate price should be carried out on a case by case basis by the regulator.

6.2.2 Recommendations addressed to EU Commission

- (1) To fully reflect the development towards NGN/NGA, the definition of Market 1 (in the new list of relevant markets) should no longer be defined service-specifically at least in the long-term.
- (2) In the forthcoming Commission Recommendation on NGA, the Commission should:
 - a. Establish a clear ladder of investment which reflects NGA developments thereby clearly including fibre LLU and SLU alongside duct access and wholesale bitstream access and explaining the role of each.
 - b. Avoid making general assumptions about the riskiness of NGA investments, but specify circumstances in which this investment may or may not be risky.

- c. Ensure that any recommendations on access pricing to reflect risk do not unduly impact competition. A project-based WACC could be a solution. Structures which require unduly high upfront contributions for access should not be permitted by NRAs unless they are proven to be compatible with effective competition.
- d. Recognise the inherent differences in costs and risk profile between incumbents and entrants. This should in particular be recognised when considering reciprocal obligations amongst operators.
- e. Clearly distinguish recommendations concerning investment/ownership sharing (of ducts or fibre) on the one hand and mandated regulated access to an SMP infrastructure on the other. The legal basis and arrangements concerning each are different. In the case of sharing, it should be recognised that effective voluntary arrangements are likely only to emerge between parties with equal bargaining power and that the sharing of an infrastructure which is hard to replicate does not itself increase competition in that infrastructure and is likely to require regulatory supervision.
- f. Ensure that markets are segmented only on the basis of actual competitive differences. Next generation access developments would only affect segmentation where the economics results in further infrastructure replication than is currently present.

6.2.3 Recommendations addressed to the ERG

- (1) The ERG should closely monitor the implementation of the Common Position on Regulatory Principles of NGA by the individual NRAs, e.g. by generating measurable 'best practice guidelines'.
- (2) The ERG should further break down and specify its position on in-house wiring in the NGA-context.
- (3) The ERG should analyse physical access to WDM-based transmission systems in the access network as an access option, evaluate the experience so far and develop an opinion on this option.
- (4) The ERG should develop a Common Position on the regulatory implications of stranded investments of alternative operators resulting from changes in the incumbents' access networks.
- (5) The ERG should develop a Common Position on the price regulation of traditional unbundling and termination services in the transition phase characterised by overlay network elements.

- (6) The ERG should make recommendations on appropriate pricing structures which allow investment recovery in NGA without undermining competition.

6.2.4 Recommendations addressed to NRAs

- (1) Regulators need to develop their regulatory approach for an NGA environment early to provide the necessary framework and predictability to all market players to conduct efficient strategies and investments in NGA.
- (2) NRAs should adapt the existing ladder of investment concept to take account of NGA to reflect FTTC and FTTH deployments.
- (3) Regulators should continue to consider an appropriately priced wholesale bitstream access as one key step in the ladder of investment concept to develop competition in the broadband access market and to support market entry.
- (4) NRAs should develop unbundling approaches for fibre loops in the context of market analysis and remedies relating to the new Market 4. The current unbundling approach defined for the copper PSTN network should be expanded in a technologically neutral manner to fibre. In case of a P2P architecture fibre local loop unbundling should be provided at the metro core locations. In case of a PON architecture fibre sub-loop unbundling should be provided at the OSDF. The location of the OSDF should allow the efficient replication of network infrastructure.
- (5) Our model results have proven the critical importance of efficient collocation at the street cabinet to replicate FTTC NGA strategies of the incumbent. NRAs should therefore impose forms of collocation which minimise total costs of the incumbent and collocation seekers.
- (6) NRAs should take care of efficient backhaul services between the street cabinet and the operator's network node by duct sharing and/or access to dark fibre giving the operators choice between both alternatives.
- (7) To minimise the level of sunk costs in the transition to and to set proper incentives for efficient investments in NGA, NRAs should use their statutory powers immediately to make the transition to NGA in their respective country transparent if they haven't done so yet.
- (8) NRAs should examine the possibility of regulatory measures for facilitating the sharing of inside wiring among operators in multi-dwelling units.
- (9) Besides introducing remedies regarding duct access, NRAs should take care of efficient implementation mechanisms and administrative procedures to minimise transaction costs of duct access; reference offers including cost based prices and

SLAs should be provided; delivery periods and response times should be reasonable.

- (10) NRAs should promote the availability of a directory, or web portal on available ducts and dark fibre, their capacity and their actual utilisation.
- (11) NRAs should set up appeal procedures for dispute resolution regarding duct access and dark fibre which are a substitute of time-consuming court appeal procedures.
- (12) Duct access should be mandated for the whole of the access and backhaul network regardless of the architecture chosen by the SMP operator.
- (13) To realise the most efficient fibre unbundling solution and to minimise the total cost of unbundled access, NRAs should define and fix the unbundling access model for GPON or EPON before the actual network deployment.
- (14) IP-bitstream access should be generally available in a NGA context with differentiated classes of service such that alternative operators have the chance to offer differentiated services and products.
- (15) NRAs should take care that providers of passive access infrastructure do not unfairly discriminate between network operators and do not request monopoly prices for using passive network elements.
- (16) NRAs might consider to develop incentive compatible transparency mechanisms to motivate incumbents to provide relevant information on their NGA transition strategy at the earliest possible time. The length of the transition phase could for instance be made dependent on the proper and timely provision of information on NGA transition.
- (17) Regulators should make sure that architectures designed by dominant operators must respect the unbundling mandate in the most efficient manner possible.
- (18) Where wholesale broadband access (bitstream) is mandated by the NRA, the SMP operator must make available, on a non-discriminatory basis, all technical capabilities embedded in its NGA, to enable alternative operators to define their own products on their own QoS. Multicast capability is one such technical capability.
- (19) Regulators should generally provide the option to choose between duct access and dark fibre access for backhaul links to enable the cost efficient construction of alternative networks.

- (20) NRAs have to take care that incumbents do not receive first-mover advantages in NGA deployment such that possible replicability will be de facto jeopardised. This means in particular that relevant access products are not only available in principle but are effectively available in due time.
- (21) Regulators should do more than they did with regard to ULL to shorten the gap between imposing NGA related remedies and the actual availability of the relevant wholesale services. In the case of ULL the implementation delay amounted to several years. Given the relevance of first-mover advantages similar gaps in NGA can endanger the (limited) potential of replicability even more or totally.
- (22) Fibre access for FTTB/H should ensure that the network architecture allows access at economically viable access points in the network which also enable innovation by competitors. Clearly determining such access obligations will also ensure that these requirements are taken into account in the construction and architecture of the network.
- (23) For circumstances where NGA roll-out to the building is viable, NRAs should examine the possibility of regulatory measures for facilitating the sharing of inside wiring among operators in multi-dwelling units.

6.2.5 Recommendations addressed to national governments and legislators

- (1) Governments should abolish uncertainty and lack of transparency on jurisdiction and dispute resolution regarding rights of way for operators.
- (2) In order to secure consistent administrative procedures of obtaining rights of way, governments should set up a clear roadmap on how to obtain public rights of way permits by creating a centralised information point by using a central web portal.
- (3) Federal, regional, and/or local governments should harmonise administrative procedures for access to rights of way and ensuring consistency in the application of these procedures across a country.
- (4) To reduce the costs of civil engineering, governments (or regulators) should ensure that any fees associated with using public rights of way should be reduced or even eliminated.
- (5) Governments should examine the feasibility of developing a framework that would allow for FTTH providers to have access to the rights of way and ducts of municipal public utilities (water, gas, sewer, electricity, public transport, traffic lights, ...).

- (6) Governments should focus on lowering barriers to infrastructure installation and investment and ensuring fair access to publicly funded ducts and networks whilst ensuring that national telecoms regulators are fully empowered to address additional bottlenecks to competition on a technologically neutral basis.
- (7) Federal, regional and/or local governments should take care that the costs of ducts, dark fibre and other infrastructure elements provided by public utilities or municipalities to operators should be fairly priced or even be reduced. The involvement of national telecoms regulators in the relevant procedures is recommended.
- (8) Governments (or regulators) should provide a framework to allow for joint construction of ducts that can be shared by potential investors in FTTH.
- (9) Authorities should give a fair consideration to (more) aerial deployment of fibre which can (under certain circumstances) be a very cost effective method of deployment.
- (10) Governments should introduce an “infrastructure certification system” for buildings to improve and standardise in-house/campus cabling (like e.g. in Korea).
- (11) Federal, regional and/or local governments should prescribe in-house ducts for all, at least all new buildings to facilitate fibre deployment in buildings.
- (12) Governments should examine access to non-telecoms ducts for telcos, at least for ducts which have been funded directly or indirectly through public funds.
- (13) In case of public funding or subsidies for expanding the regional coverage of NGA, governments should take care of effective tender processes and regulated open access fibre architectures.
- (14) Authorities should ensure a proper documentation of all infrastructure laid out on public grounds in order to enable the identification of free space and infrastructure owners easily and fast. In addition, the use of the infrastructure on public grounds has to be documented so that spare capacity (e.g. sub-ducts, fibres) can be recognised fast and easily.

6.2.6 Recommendations addressed to alternative operators

- (1) Alternative operators should take care of the overall competitive landscape before making NGA investment decisions. Against the backdrop of the potentials of intermodal competition, they must consider losses from not upgrading access networks for NGA as well as gains from upgrading them.
- (2) Alternative operators should develop policies to construct joint ducts and fibre for infrastructure sharing between themselves.
- (3) Alternative operators should examine the role of public-private partnerships in the deployment of ducts and dark fibres as well as third party infrastructure providers for duct sharing.
- (4) In countries and towns where alternative operators are first-movers in deploying FTTB/H, they should consider to offer wholesale services on a voluntary basis, e.g. in-house cabling, fibre sub-loops, fibre loops.
- (5) Alternative operators should consider swapping options for access infrastructure in different regions amongst themselves.
- (6) Alternative operators should be open for or even motivate private investors or the Government/local authorities to invest in passive fibre access infrastructure and to provide this infrastructure in a non-discriminatory way to different operators.

6.2.7 Recommendations addressed to incumbent operators

- (1) Incumbents should provide information and transparency into their NGA deployment strategy to ensure that deployments are designed to be compliant with relevant regulatory principles.
- (2) Incumbents could and should reduce their own risk and cost of rolling-out NGA by considering voluntary sharing of infrastructure and access provision to alternative operators.

Bibliography

- AGCOM (2007): "Consultazione pubblica sugli aspetti regolamentari relativi all'assetto della rete d'accesso ed alle prospettive delle reti di nuova generazione a larga banda"; Allegato A and Allegato B alla Delibera n. 208/07/CONS; Roma; May
- Amado da Silva, J. (2008): "Portugal: Duct Access in Practice", presentation at the ECTA Workshop "High Speed Europe", Brussels, June 25
- Amendola, G.B. and L.M. Pupillo (2008): "The economics of Next Generation Access networks and regulatory governance: Towards geographic patterns of regulation"; in: Communications & Strategies, no. 69, 1st quarter 2008, p. 85
- Analysys (2006): "Fibre in the last mile: the business case for FTTP and VDSL", Analysys Research Limited, Cambridge (UK)
- Analysys (2007a): "The business case for sub-loop unbundling in the Netherlands", study prepared for OPTA, January
- Analysys (2007b): "The business case for sub-loop unbundling in Dublin", study prepared for Comreg, December
- Analysys Mason (2008): "The business case for fibre-based access in the Netherlands", final report for OPTA, July 24
- ARCEP (2008): "Consultation publique sur le déploiement et la mutualisation de la partie terminale des réseaux en fibre optique"; Consultation publique du 22 mai au 27 juin; http://www.arcep.fr/uploads/tx_gspublication/consult-ftth-mutualisation-mai08.pdf
- Arthur D. Little (2006): "Nieuwe generatie netwerken in Europa, Breedband in 2011 en daarna". Study prepared for Liberty Global. http://www.vecal.nl/downloads/docs/ADL_Report.pdf.
- AT Kearney and Planning SA. (2008): "Developing the Hellenic Ministry of Transport and Communications 5 year broadband strategy for Greece", Athens, May
- Avisem (2007a): "Etude portant sur les modalités de déploiement d'une boucle locale fibre optique", study prepared for ARCEP, June
- Avisem (2007b): "Etude portant sur les spécifications techniques des infrastructures de génie civil susceptibles de supporter des réseaux d'accès FTTH "; partie 2 de l'étude : Eléments de spécifications des infrastructures; study prepared for ARCEP, September
- Bauer, J. (2005): "Unbundling policy in the United States – Players, outcomes and effects"; in: Communications & Strategies, no. 57, 1st quarter, p. 59
- BIPT Institut Belge des service postaux et des télécommunications (2008): "Communication du conseil de l'IBPT du 7 juillet 2008 concernant l'impact de la fermeture des centraux sur les marchés d'access à large bande", Brussels, July 7
- de Baillenx, O. (2008): "High Speed Europe", presentation at the ECTA Workshop "High Speed Europe", Brussels, June 25
- Chan, T. and G. Lynch (2008): "Who is Axia—the new mystery NBN player?" in: Communications Day, ASEAN edition, May 7
- CMT (2008): "Principios y líneas maestras de la futura regulación de las redes de Acceso de Nueva Generación (NGA)", January

- Elixmann, D. (2001): "Der Markt für Übertragungskapazität in Nordamerika und Europa", WIK-Diskussionsbeiträge Nr. 224, Bad Honnef
- EU Commission (2008): "eCommunications household survey": The results of a special Eurobarometer survey, No. 293, June
- European Parliament (Committee on Industry, Research and Energy, 2008): "Draft Report on the proposal for a directive of the European Parliament and of the Council amending Directive 2002/21/EC on a common regulatory framework for electronic communications networks and services, Directive 2002/19/EC on access to, and interconnection of, electronic communications networks and services, and Directive 2002/20/EC on the authorisation of electronic communications networks and services"; (COM(2007)0697 – C6-0427/2007 – 2007/0247(COD)); Rapporteur: Catherine Trautmann; April 23
- ERG (2007a): "ERG Opinion on Regulatory Principles of NGA", October
- ERG (2007b): "Supplementary Document", October
- Gauthey, G. (2007): "FTTH in France", presentation at WIK Conference "The way to Next Generation Access Networks", March 21; Königswinter
- Groenewald, A. (2008): "Bush graft", in: Total Telecom Magazine, June, p. 33
- Grobe, K. and J-P Elbers (2008): "PON in Adolescence: From TDMA to WDM-PON", in: IEEE Communications Magazine, January, pp. 26
- Hennes, V. (2007): "From FTTH pilot to pre-rollout in France"; presentation at WIK Conference "The way to Next Generation Access Networks", March 21; Königswinter
- Hutcheson, L. (2008): "Current Status and the Future", in: IEEE Communications Magazine, July, pp. 90
- IDA (2007a): "Media Briefing - Next Generation National Broadband Network for Singapore (Next Gen NBN)"; by KhoongHock Yun, December 11
- IDA (2007b): "Singapore's Next Generation National Broadband Network Project"; Qualification Document for NetCo RFP
- IDA (2008): "Next Generation National Broadband Network for Singapore (Next Gen NBN)", presentation by KhoongHock Yun, April 7
- IDATE (2008): "UltraBroadband Overview", UltraBroadband Seminar, Paris, April 3 (presented by Roland Montagne)
- JP Morgan (2006): "The Fibre Battle", December
- Katagiri, Y. (2008): "Recent Regulatory Reform in Japanese Telecommunications"; slide presentation at the International WIK Conference "Review of the European Framework for Electronic Communications", Bonn, Germany; April 24 - 25
- Lundberg, A. (2008): "Stokab", presentation at the OECD workshop on fibre investment and policy challenges, April 1, Stavanger
- Lombard, D. (2007): "France Telecom Investor Day: conclusion", www.francetelecom.com/fr_FR/finance/investisseurs/journees-invest/att00003164/14-conclusion.pdf, December

- Lynch, G. (2008a): "Opel cancellation portends similar FTTN issues", in: Communications Day, issue 3244, April 3
- Metzler, A., Stappen, C. unter Mitarbeit von D. Elixmann (2003): "Aktuelle Marktstruktur der Anbieter von TK-Diensten im Festnetz sowie Faktoren für den Erfolg von Geschäftsmodellen", Wik-Diskussionsbeiträge Nr. 247, Bad Honnef
- OECD (2008a): "Public rights of way for fibre deployment to the home", DSTI/ICCP/CISP(2007)5/Final, April 4
- OECD (2008b): "Developments in fibre technologies and investment", DSTI/ICCP/CISP(2007)4/Final, April 3
- Ovum (2008): "Estudo sobre o impacto das Redes de Próxima Geração no mercado", study prepared for ANACOM, June 11
- Pupillo, L. (2008): "Regulation, Deregulation and Competition in Next Generation Access Networks: The geographic market approach as a way forward!"; presentation at WIK's International Conference "Review of the European Framework for Electronic Communications; Bonn, Germany; April 24 – 25
- Rodriguez, R. (2008): "Regulation on a NGAN environment", presentation at the ECTA Workshop "High Speed Europe", Brussels, June 25
- Schäfer, R. and A. Schöbel (2005): "Stand der Backbone-Infrastruktur in Deutschland – Eine Markt- und Wettbewerbsanalyse", WIK-Diskussionsbeiträge Nr. 265, Bad Honnef.
- Taniwaki, Y. (2008): "Broadband Competition Policy in Japan", presentation by Ministry of Internal Affairs & Communications (MIC), March
- Vogelsang, I. (2005): "Opinion on unbundling policy in the United States", interview by Karl-Heinz Neumann; in: Communications & Strategies, no. 57, 1st quarter, p. 109
- Williamson, R., Klein, J., Reynolds, M. and R. Jones (2008): "Assessment of the theoretical limits of copper in the last mile", Final report prepared for OFCOM, July 6
- Wulf, A. (2007): "Access requirements and access options in a VDSL environment", presentation at WIK's VDSL Conference, Königswinter, Germany, March

Annex 1

Details of non-EU country analysis

Singapore

Table A-1: NetCo tenderers in Singapore

Consortium	Consortium Lead	Members
Infinity Consortium	<ul style="list-style-type: none"> City Telecom (H.K.) Limited 	<ul style="list-style-type: none"> MobileOne Ltd StarHub Ltd
OpenNet Consortium	<ul style="list-style-type: none"> Axia NetMedia Corporation (30 %) 	<ul style="list-style-type: none"> Singapore Press Holdings Ltd. (25 %); Singapore Telecommunications Pte Ltd. (30 %) Singapore Power Telecommunications Pte Ltd. (15 %)

Source: <http://www.ida.gov.sg/Infrastructure/20060919190208.aspx>; Communications Day, May 6, 2008; issue 3266

Table A-2: OpCo tenderers in Singapore

/N	Name pre-qualified companies as of April 2008
1	Alcatel-Lucent Singapore Pte Ltd
2	Axia NetMedia Corporation
3	BT Singapore Pte Ltd
4	City Telecom (H.K.) Limited
5	Deutsche Telekom Asia Pte Ltd
6	MobileOne Ltd
7	Nippon Telegraph and Telephone West Corporation
8	Nokia Siemens Networks Singapore Pte Ltd
9	Singapore Computer Systems Ltd
10	Singapore Telecommunications Ltd
11	StarHub Ltd

Source: <http://www.ida.gov.sg/Infrastructure/20060919190208.aspx>